



GlobAlum
Globaly Aluminum Passion

GF60

**CURTAIN WALL
SERIES GF60**



1. Definition

A curtain wall system is a nonbearing wall, usually aluminum framed filled with glass and/or light material, fixed to the outside of a building and serving especially as cladding and outer covering of a building, but merely keep the weather out and the occupants in. As the curtain wall is non-structural it can be made of a lightweight material, reducing construction costs. When glass is used as the curtain wall, a great advantage is that natural light can penetrate deeper within the building. The curtain wall facade does not carry any dead load weight from the building other than its own dead load weight. The wall transfers horizontal wind loads that are incident upon it to the main building structure through connections at floors or columns of the building. A curtain wall is designed to resist air and water infiltration, sway induced by wind and seismic forces acting on the building, and its own dead load weight forces.

According to European Standard EN 13830, a lightweight façade is defined as: “A framework of connected vertical and horizontal construction elements that is anchored to the structure of the building ready for final fitting with lightweight outer layer panels. It thus forms a continuous and lightweight surface, which completely separates the interior of the building from the outside. This façade provides, either of itself, or in conjunction with some other element of the structure of the building, all the normal characteristics of an outside wall, but has none of the load-bearing characteristics of the main structure of the building.”

In basic terms, lightweight façades consist of vertical elements (mullions) and horizontal elements (transoms), which form a framework into which are installed:

- Glass for viewing and to allow natural light to enter.
- Opaque panels for blank zones.
- Suitably constructed units to allow ventilation and/or the cleaning of the façade.

Lightweight façades are always fixed to the supporting structure of the building, but do not form part of it. That is to say they do not increase the strength of the structure of the building, but they do rest upon it. For this reason, a lightweight façade must be designed to be able to resist the forces that act upon its components itself, and then transmit them to the main structure of the building.

2. Classification of lightweight facades:

2.1. According to architectural types:

- Visible grids
- 2way silicon glazing, horizontal or vertical
- Silicone glazing

2.2. According to type of assembly:

- Unitized
- Conventional / stick system
- Semi unitized

2.3. According to type of construction:

- Curtain wall
- Panel facade

From a constructional point of view, a lightweight façade can be considered either as a curtain wall, or as a panel façade depending upon the constructive relationship between the lightweight façade and the subfloors of the structure.

A façade is considered to be a curtain wall when it passes in an unbroken form in front of the subfloors of the building. In this case, the supporting structure of the lightweight façade is suspended from the subfloors of the structure in the manner of a “curtain”.

A panel façade is when there is an interruption in the façade at each subfloor, with consequent separation of panels or independent zones. As a consequence, the supporting structure of the lightweight façade is supported by each subfloor.

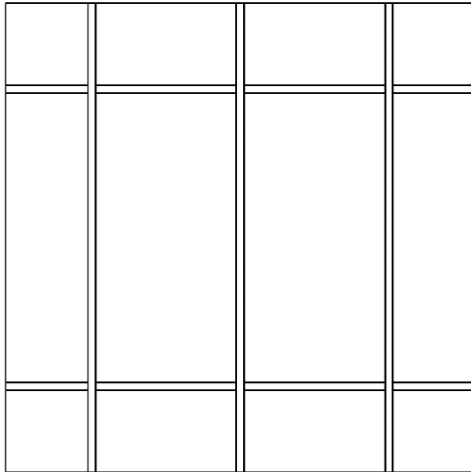

VISIBLE GRID

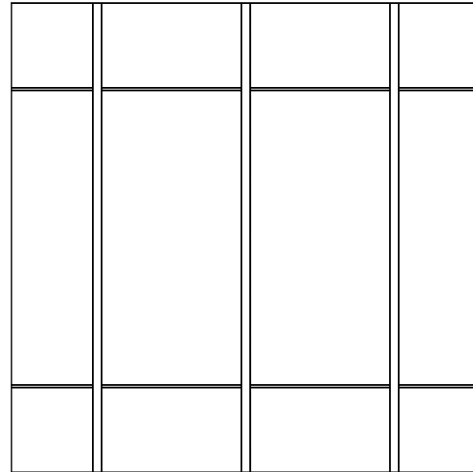

TRAME VERTICAL

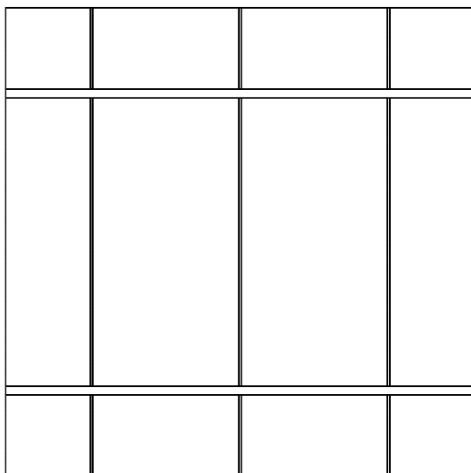

TRAME HORIZONTAL

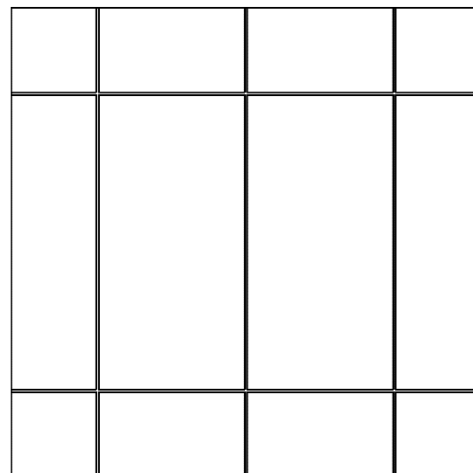

SILICON GLAZING

Image 01
 Classification of lightweight façade
 According to architectural types



Image 02
Curtain wall and panel façade

3. Basic requirements of lightweight facades:

In general terms, the basic requirements of facade are:

3.1. Comfort

Feeling comfort provide by façade to the users is depend in a large part ability of the facade to act as selective filter in relation between the external and internal environments such as:

- 3.1.1. Thermal performance
- 3.1.2. Acoustic performance
- 3.1.3. Daylighting and solar protection
- 3.1.4. Condensation resistance

These factors are the most important selection guidelines for the system of curtain wall or panel façade and type of filling materials and/or glazing.

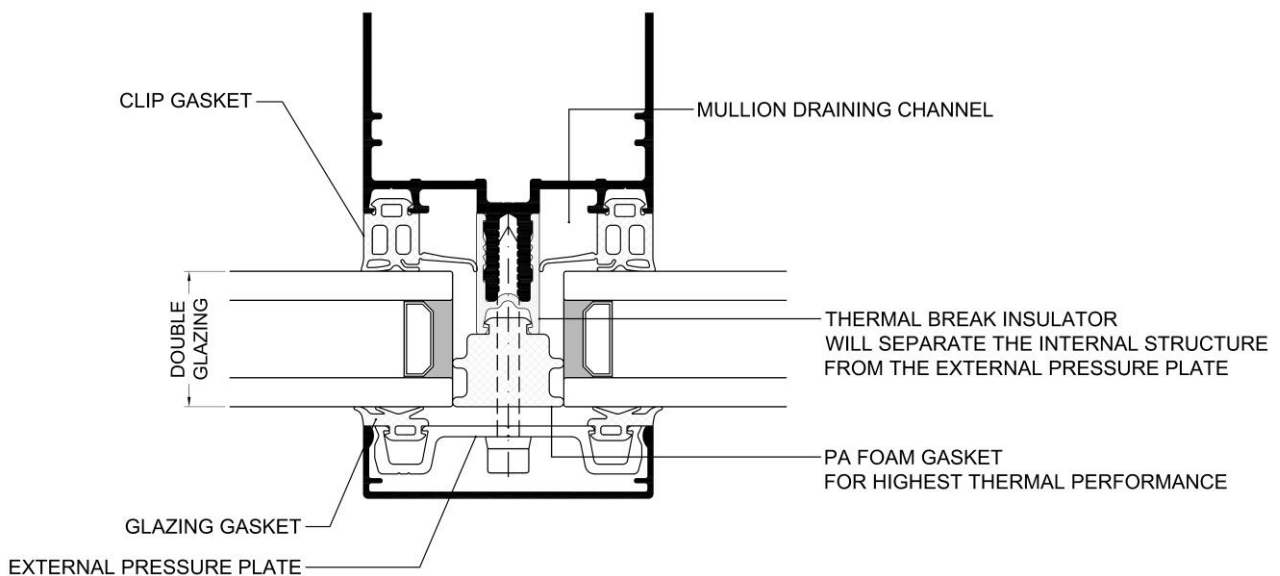

4. Stability

- 4.1. Loading
 - 4.1.1. Wind load
 - 4.1.2. Dead load
 - 4.1.3. Seismic load
- 4.2. Fire stopping
- 4.3. Electrical discharge
- 4.4. Air and water tightness

5. Use

- 5.1. Functionality
- 5.2. Durability

GF60

CURTAIN WALL SYSTEM

GF60 is a 60mm. width face curtain wall that have several variation of system to fulfill all the requirements of modern architects.

GF60 advantage:

- Same profile used for mullion and transom
- Controlled drainage system by using special transom insulator
- Fast assembling (no cutting or notching on mullion or transom)
- Less consumption of profiles due to use same mullion/transom
- Designed to increase structural stability with lower weight
- Compatible to increase structural stability with available steel profiles insertion

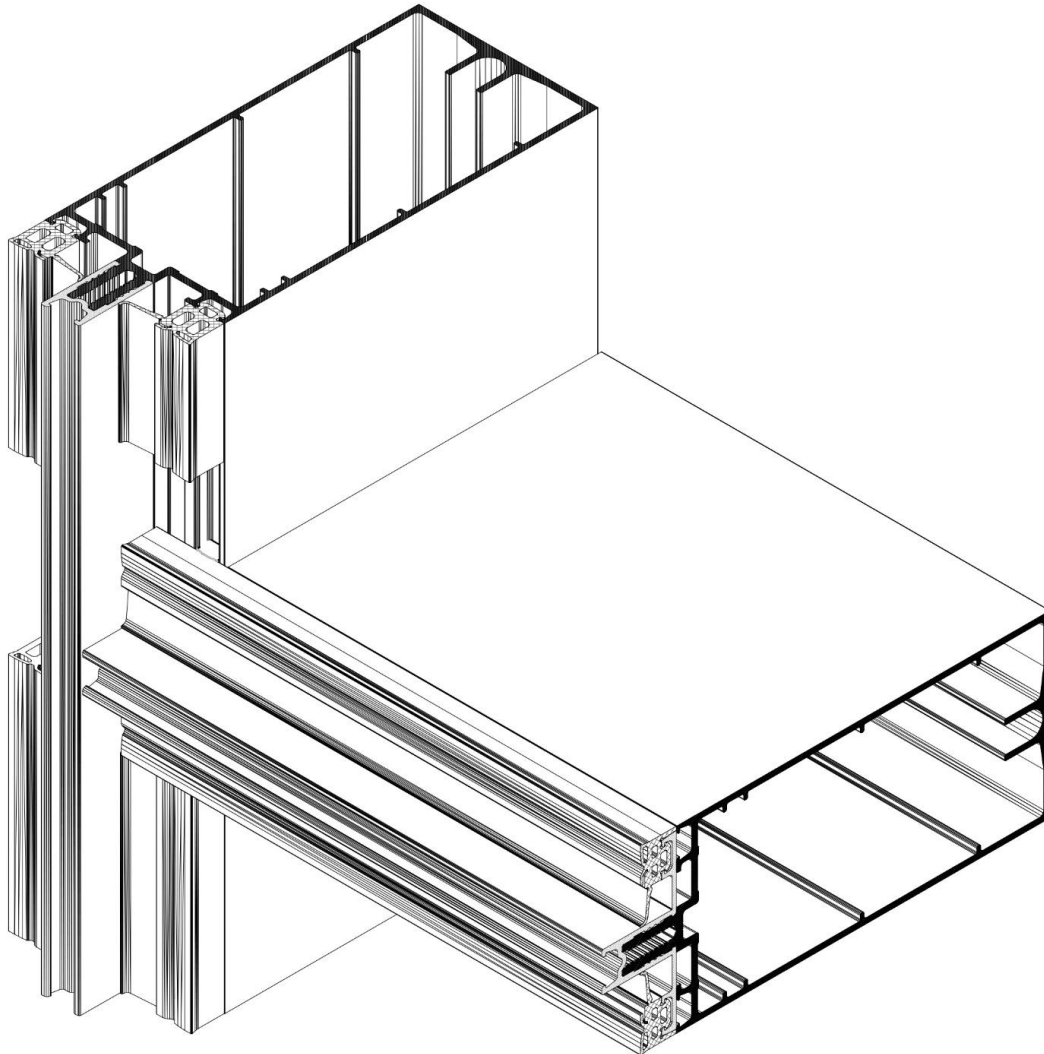

Table 1- 01

جدول سرعت باد در شهر های ایران

Wind velocity table of Iran cities

No.	City	Wind Velocity Km/h	سرعت باد	نام شهر	ردیف
1	ABADAN	90		آبادان	۱
2	ABADEH	100		آباده	۲
3	ABALI	110		آبعلی	۳
4	ARAK	90		اراک	۴
5	ARDEBIL	130		اردبیل	۵
6	UROMIE	90		ارومیه	۶
7	AGHAJARI	110		آغاجاری	۷
8	ISFAHAN	110		اصفهان	۸
9	OMIDIEH	110		امیدیه	۹
10	AHWAZ	110		اهواز	۱۰
11	IRANSHAHR	110		ایرانشهر	۱۱
12	BABOLSAR	100		بابلسر	۱۲
13	BOJNOURD	130		بجنورد	۱۳
14	BAM	110		بم	۱۴
15	BANDAR ANZALI	110		بندر انزلی	۱۵
16	BANDAR ABBAS	100		بندر عباس	۱۶
17	BANDAR LENGEH	90		بندر لنگه	۱۷
18	BOUSHEHR	100		بوشهر	۱۸
19	BIRJAND	90		بیرجند	۱۹
20	PARS ABAD MOGHAN	100		پارس آباد مغان	۲۰
21	TABRIZ	110		تبریز	۲۱
22	TORBAT HEYDARIEH	80		تربت حیدریه	۲۲
23	TEHRAN	100		تهران	۲۳
24	JASK	100		جاسک	۲۴
25	SIRI	110		جزیره سیری	۲۵
26	KISH	100		جزیره کیش	۲۶
27	CHABAHAR	90		چابهار	۲۷
28	KHORRAM ABAD	80		خرم آباد	۲۸
29	KHOY	90		خوی	۲۹

Table 1- 01

جدول سرعت باد در شهر های ایران

Wind velocity table of Iran cities

No.	City	Wind Velocity Km/h	سرعت باد	نام شهر	ردیف
30	DEZFOUL	110		دزفول	۳۰
31	RAMSAR	90		رامسر	۳۱
32	RASHT	90		رشت	۳۲
33	ZABOL	120		زابل	۳۳
34	ZAHEDAN	130		زاهدان	۳۴
35	ZANJAN	80		زنجان	۳۵
36	SABZEVAR	90		سبزوار	۳۶
37	SARAKHS	110		سرخس	۳۷
38	SAGHEZ	100		سقز	۳۸
39	SEM NAN	80		سمنان	۳۹
40	SANANDAJ	90		سنندج	۴۰
41	SHAHROUD	80		شاهرود	۴۱
42	SHAHRE KORD	80		شهر کرد	۴۲
43	SHIRAZ	80		شیراز	۴۳
44	TABAS	90		طبس	۴۴
45	FASA	90		فسا	۴۵
46	QA-EM SHAHR	90		قائم شهر	۴۶
47	QAZVIN	100		قزوین	۴۷
48	QOM	90		قم	۴۸
49	KASHAN	100		کاشان	۴۹
50	KERMAN	130		کرمان	۵۰
51	KERMANSHAH	90		کرمانشاه	۵۱
52	GORGAN	80		گرگان	۵۲
53	MARAGHE	110		مرآغه	۵۳
54	MASH'HAD	90		مشهد	۵۴
55	MANJIL	130		منجیل	۵۵
56	NOSHAHR	90		نوشهر	۵۶
57	HAMEDAN	100		همدان	۵۷
58	YAZD	110		یزد	۵۸

Table 1-02
Topography and terrain category
تعریف موقعیت جغرافیایی ساختمان

A	<p>ساختمانهای واقع در محدوده شهر ها یا کنار شهر ها که دارای تراکم ساختمان و درخت در بالا دست که تا فاصله یک کیلومتر یا ۲۰ برابر ارتفاع ساختمان ، هرکدام که بیشتر باشد ، امتداد پیدا کند.</p> <p>Urban or sub-urban areas, wooded areas or other terrain with numerous closely spaced obstruction in the upwind direction for a distance greater than one kilometer or 20 times more than building height , whichever is greater.</p>
B	<p>ساختمانهای واقع در محلهایی که تراکم ساختمان و درختان بصورت پراکنده بوده و یا در کنار دریاچه ، دریا و یا ساحل باز قرار دارند.</p> <p>Open terrain with scattered obstruction includes flat open country grasslands and lake sea or open coast.</p>

- برای مشخص کردن فشار باد بر اساس ارتفاع بالاترین تراز نما در گروه **A** از جدول ۱-۰۳ استفاده شود.
- برای مشخص کردن فشار باد بر اساس ارتفاع بالاترین تراز نما در گروه **B** از جدول ۱-۰۴ استفاده شود.

- To determine wind load base on top of curtain wall height for category A refer to table 1-03
- To determine wind load base on top of curtain wall height for category B refer to table 1-04

Table 1- 03

جدول فشار باد (نیوتن بر متر مربع) برای نواحی داخل شهر و با ساختمانهای اطراف در قسمتهای میانی نما
بر اساس مقررات ملی و برای ساختمانهای معمولی

Wind load for category A base on top of curtain wall height

Top of Curtain wall in meter ارتفاع بالاترین تراز نما به متر	Wind Velocity in Km/h					
	سرعت باد به کیلومتر بر ساعت					
	80	90	100	110	120	130
Up to 10	487	616	761	920	1095	1286
11 - 15	521	659	813	984	1171	1375
16 - 20	567	718	887	1073	1277	1499
21 - 25	607	768	948	1147	1365	1602
26 - 30	641	811	1001	1212	1442	1692
31 - 35	671	850	1049	1269	1510	1772
36 - 40	699	884	1092	1321	1572	1845
41 - 45	724	916	1131	1368	1629	1911
46 - 50	747	945	1167	1412	1681	1973
51 - 55	769	973	1201	1453	1730	2030
56 - 60	789	999	1233	1492	1775	2084
61 - 65	808	1023	1263	1528	1818	2134
66 - 70	826	1046	1291	1562	1859	2182
71 - 75	844	1068	1318	1595	1898	2228
76 - 80	860	1089	1344	1626	1935	2271
81 - 85	876	1109	1369	1656	1971	2313
86 - 90	891	1128	1392	1685	2005	2353
91 - 95	906	1146	1415	1712	2038	2392
96 - 100	920	1164	1437	1739	2069	2429

برای قسمتهای گوشه نما، اعداد فوق می بایست در ضریب ۱.۳۳ ضرب شوند.
قسمت گوشه بر اساس تعریف برابر ۱/۸ عرض ساختمان، حداقل یک و حداکثر ۲ متر در نظر گرفته میشود.
مقادیر جدول بالا با دقت و بر اساس قوانین و مقررات ملی ساختمان تنظیم شده اند. با این حال نمیتوانند جایگزین محاسبات انجام شده توسط یک متخصص باشند

For corner area, the given numbers should be multiply by 1.33

Corner area defined as Min 1 meter or building width/8 or Max. 2 meter.

All above stated data were checked carefully and are in accordance with national building codes and laws. But in anyhow can not be replaced with calculation done by an expert.

Table 1- 04

بر اساس مقررات ملی و برای ساختمانهای معمولی

Wind load for category B base on top of curtain wall height

Top of Curtain wall in meter ارتفاع بالاترین تراز نما به متر	Wind Velocity					
	سرعت باد					
	80 Km/h	90 Km/h	100Km/h	110 Km/h	120 Km/h	130 Km/h
Up to 10	696	880	1087	1315	1565	1837
11 - 15	754	955	1179	1426	1697	1992
16 - 20	799	1011	1248	1511	1798	2110
21 - 25	835	1057	1305	1579	1880	2206
26 - 30	866	1097	1354	1638	1949	2288
31 - 35	894	1131	1396	1689	2011	2360
36 - 40	918	1162	1434	1735	2065	2423
41 - 45	940	1189	1468	1776	2114	2481
46 - 50	960	1215	1499	1814	2159	2534
51 - 55	978	1238	1528	1849	2201	2583
56 - 60	995	1260	1555	1882	2239	2628
61 - 65	1011	1280	1580	1912	2275	2671
66 - 70	1026	1299	1604	1941	2309	2710
71 - 75	1041	1317	1626	1968	2342	2748
76 - 80	1054	1334	1647	1993	2372	2784
81 - 85	1067	1351	1667	2017	2401	2818
86 - 90	1079	1366	1686	2041	2429	2850
91 - 95	1091	1381	1705	2063	2455	2881
96 - 100	1102	1395	1722	2084	2480	2911

برای قسمتهای گوشه نما، اعداد فوق می بایست در ضریب ۱.۳۳ ضرب شوند.

قسمت گوشه بر اساس تعریف برابر ۱/۸ عرض ساختمان ، حداقل یک و حداکثر ۲ متر در نظر گرفته میشود.

مقادیر جدول بالا با دقت و بر اساس قوانین و مقررات ملی ساختمان تنظیم شده اند. با این حال نمیتوانند جایگزین

محاسبات انجام شده توسط یک متخصص باشند

For corner area, the given numbers should be multiply by 1.33

Corner area defined as Min. 1 meter , building width/8 , Max. 2 meter.

All above stated data were checked carefully and are in accordance with national building codes and laws. But in anyhow can not be replaced with calculation done by an expert.

Table 1-05
Required Moment of Inertia for mullion based on 1000 N/m² Wind Load

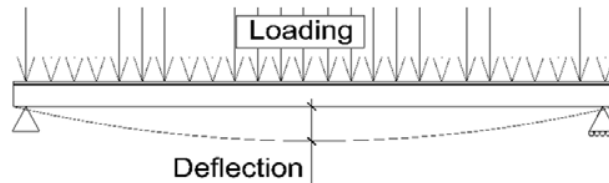

$$I_x = \frac{5 \times q \times L^4}{384 \times E \times f} \times 10^5$$

Deflection = L/200 or Max. 15mm.
 E (Aluminum) = 70000 N/mm²

Span In mm. فاصله بين براكتها به ميليمتر	Load width in mm. عرض تحت فشار به ميليمتر									
	600	800	1000	1200	1400	1600	1800	2000	2200	2400
3000	60	80	100	121	141	161	181	201	221	241
3100	69	92	115	137	160	183	206	229	252	275
3200	78	104	130	156	182	208	234	260	286	312
3300	88	118	147	176	206	235	265	294	324	353
3400	99	133	166	199	232	265	298	331	365	398
3500	112	149	186	223	261	298	335	372	409	447
3600	125	167	208	250	292	333	375	417	458	500
3700	139	186	232	279	325	372	418	465	511	558
3800	155	207	259	310	362	414	465	517	569	621
3900	172	230	287	344	402	459	516	574	631	689
4000	190	254	317	381	444	508	571	635	698	762
4100	210	280	350	421	491	561	631	701	771	841
4200	232	309	386	463	540	617	695	772	849	926
4300	254	339	424	509	594	678	763	848	933	1018
4400	279	372	465	558	651	744	837	930	1023	1116
4500	305	407	509	610	712	814	915	1017	1119	1220
4600	333	444	555	666	777	888	999	1110	1222	1333
4700	363	484	605	726	847	968	1089	1210	1331	1452
4800	395	527	658	790	922	1053	1185	1317	1448	1580
4900	429	572	715	858	1001	1144	1287	1430	1573	1716
5000	465	620	775	930	1085	1240	1395	1550	1705	1860
5100	503	671	839	1007	1175	1342	1510	1678	1846	2013
5200	544	725	907	1088	1269	1451	1632	1813	1995	2176
5300	587	783	978	1174	1370	1566	1761	1957	2153	2348
5400	633	844	1054	1265	1476	1687	1898	2109	2320	2531
5500	681	908	1135	1362	1589	1816	2043	2270	2496	2723
5600	732	976	1220	1463	1707	1951	2195	2439	2683	2927

Moment of inertia given in cm⁴

Table 1- 06
Required Moment of Inertia based on 1000 N/m2 Wind Load

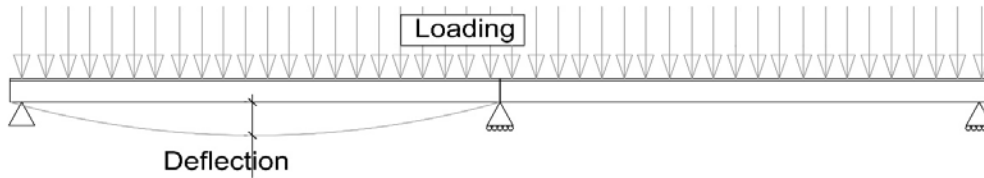

$$I_x = \frac{q \times L^4}{2960 \times E \times f} \times 10^5$$

Deflection = L/200 or Max. 15mm.
E (Aluminum)= 70000 N/mm2

Span In mm. ارتفاع لامل به میلیمتر	Load width in mm. عرض تحت فشار به میلیمتر									
	600	800	1000	1200	1400	1600	1800	2000	2200	2400
5000	14	19	24	29	34	39	43	48	53	58
5100	15	20	26	31	36	41	46	51	56	61
5200	16	22	27	33	38	43	49	54	60	65
5300	17	23	29	34	40	46	52	57	63	69
5400	18	24	30	36	43	49	55	61	67	73
5500	18	24	29	35	41	47	53	59	65	71
5600	19	25	32	38	44	51	57	63	70	76
5700	20	27	34	41	48	54	61	68	75	82
5800	22	29	36	44	51	58	66	73	80	87
5900	23	31	39	47	55	62	70	78	86	94
6000	25	33	42	50	58	67	75	83	92	100
6100	27	36	45	53	62	71	80	89	98	107
6200	29	38	48	57	67	76	86	95	105	114
6300	30	41	51	61	71	81	91	101	112	122
6400	32	43	54	65	76	86	97	108	119	130
6500	34	46	57	69	80	92	103	115	126	138
6600	37	49	61	73	85	98	110	122	134	147
6700	39	52	65	78	91	104	117	130	143	156
6800	41	55	69	83	96	110	124	138	151	165
6900	44	58	73	88	102	117	131	146	160	175
7000	46	62	77	93	108	124	139	155	170	185
7100	49	65	82	98	114	131	147	164	180	196
7200	52	69	86	104	121	138	156	173	190	208

Moment of inertia given in cm4

STRUCTURAL STABILITY TABLE
Series GF60

Description		Physical Properties				Standard Profile Insertion			Rectangle Tube Insertion*			Flat Bar Insertion*		
Profile Number	Series	Jx in cm4	Jy in cm4	Wx in cm4	Wy in cm4	Profile Number	Jx in cm4	Jy in cm4	Profile Size in mm.	Jx in cm4	Jy in cm4	Profile Size in mm.	Jx in cm4	Jy in cm4
1000311	F60	42.33	25.33	9.79	8.44	-	-	-	50 x 40x3	17.07	11.96	8x49	7.84	0.2
1000312	F60	79.01	31.11	15.06	10.37	-	-	-	50 x 60x3	31.59	23.7	8x69	21.9	0.29
1000313	F60	132.15	37.18	21.15	12.39	-	-	-	50 x 80x3	63.55	30.34	8x89	46.99	0.37
1000314	F60	207.62	45.7	28.43	15.23	-	-	-	50 x 100x3	110.23	36.98	8x109	86.33	0.46
1000315	F60	306.44	52.54	36.33	17.51	-	-	-	**	-	43.61	8x129	143.11	0.55
1000316	F60	469.74	62.91	47.1	20.97	1000335	326.89	37.44	**	-	46.93	8x149	220.52	0.63
1000317	F60	637.06	73.26	57.51	24.42	-	-	-	**	-	56.88	8x169	321.78	0.72
1000328	F60	863.38	77.94	68.52	25.98	1000329	614	44.83	**	-	60.2	8x185	422.1	0.78
1000318	F60	1083.15	92.58	79.46	30.86	-	-	-	**	-	63.52	8x193	479.27	0.82
									**					
									**	There is no standard rectangle tube size				
									**	Two profiles of rectangle tubes can be used				

*For Steel rectangle tubes and flat bars: Jx or Jy x 3 x 0.8

Structural stability calculation

1. Mullions.
 - 1.1. Single Span Curtain Wall

$$I_x = \frac{5 \times q \times L^4}{384 \times E \times f} \times 10^5$$

Where:

I_x = Moment of inertia in cm^4

P = designed wind load in N/m^2 or Pa

A = Left portion width in meter

B = Right portion width in meter

$q = ((A+B)/2) \times p$

L = Mullion length (Span) in meter.

E = Young's Modulus in N/mm^2

$E_{aluminum} = 70,000 N/mm^2$

f = Maximum frontal deflection in mm.

H_2 = biggest height of glazing panel.

According to EN 13830, Maximum deflection should be $L/200$ or 15 mm. whichever is less with taking into account that double glazing edge deflection should not be more than 12mm. in accordance with EN 1279-5

Formula to check the glazing edge deflection:

$$R = \frac{f}{12} \left(\frac{H_2}{L} \right)^2 \leq 1$$

If $R > 1$ then correction factor equal to R should be multiplied to calculated I_x

Example 1:

$P = 1600 N/m^2$, $L = 3.40 m.$, $A = 1.2m.$, $B = 1.2m.$, $H_2 = 3.4 m.$

$q = ((A+B)/2) \times p = 1920$, $f_{max} = 15mm.$

$$I_x = \frac{5 \times 1920 \times 3.4^4}{384 \times 70000 \times 15} \times 10^5 = 318.2 cm^4$$

$$R = \frac{15}{12} \left(\frac{3.4}{3.4} \right)^2 = 1.25$$

Corrected $I_x = 318.2 \times 1.25 = 397.75 cm^4$

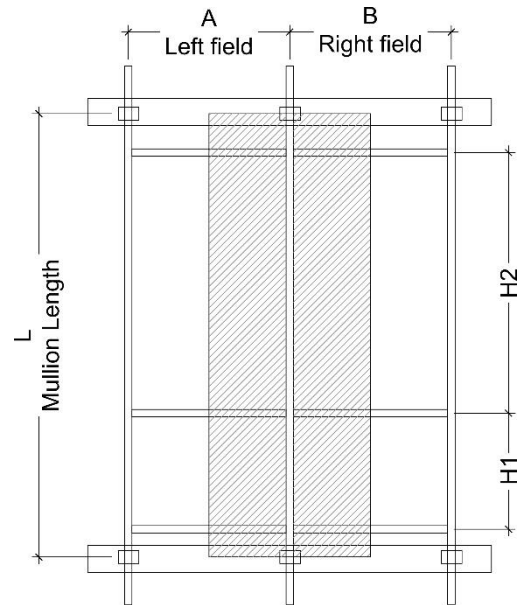

SINGLE SPAN
LOADING SCHEME

1.2. Equal Double Span Curtain Wall

$$I_x = \frac{q \times L^4}{2960 \times E \times f} \times 10^5$$

Where:

I_x = Moment of inertia in cm^4

P = designed wind load in N/m^2 or Pa

A = Left portion width in meter

B = Right portion width in meter

$q = ((A+B)/2) \times p$

L = Mullion length in meter.

E = Young's Modulus in N/mm^2

$E_{\text{aluminum}} = 70,000 \text{ N/mm}^2$

f = Maximum frontal deflection in mm.

H_2 = biggest height of glazing panel.

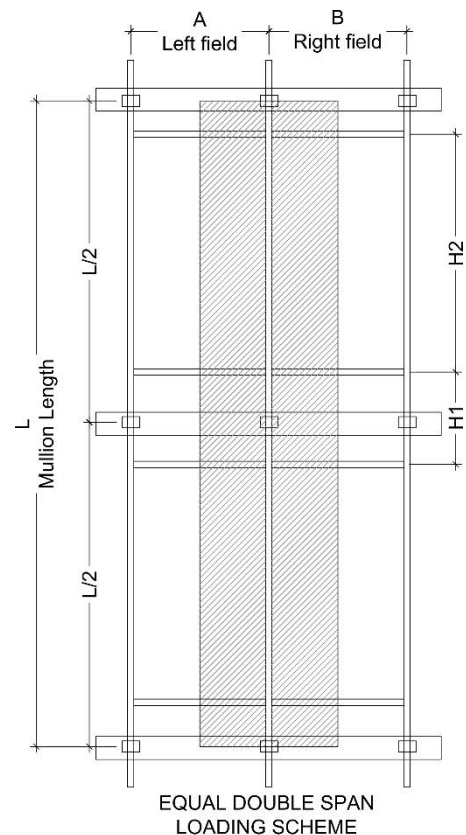

According to EN 13830, Maximum deflection should be $(L/2)/200$ or 15 mm. whichever is less with taking into account that double glazing edge deflection should not be more than 12mm. in accordance with EN 1279-5

Formula to check the glazing edge deflection:

$$R = \frac{f}{12} \left(\frac{H_2}{L/2} \right)^2 \leq 1$$

If $R > 1$ then correction factor equal to R should be multiplied to calculated I_x

Example 2:

$P = 1600 \text{ N/m}^2$, $L = 6.80 \text{ m}$, $A = 1.2 \text{ m}$, $B = 1.2 \text{ m}$, $H_2 = 2.8 \text{ m}$.

$q = ((A+B)/2) \times p = 1920$, $f_{\text{max}} = 15 \text{ mm}$.

$$I_x = \frac{1920 \times 6.8^4}{2960 \times 70000 \times 15} \times 10^5 = 132.08 \text{ cm}^4$$

$$R = \frac{15}{12} \left(\frac{2.8}{3.4} \right)^2 = 0.847$$

Hence $R < 1$, No correction required.

1.3. Unequal Double Span Curtain Wall

$$I_x = \frac{q \times (L_1)^2}{384 \times E \times f} \times (9 \times L \times L_1 - 3L^2 - 4L_1^2) \times 10^5$$

Where:

I_x = Moment of inertia in cm^4

P = designed wind load in N/m^2 or Pa

A = Left portion width in meter

B = Right portion width in meter

$q = ((A+B)/2) \times p$

L = Mullion length in meter.

L_1 = Larger span in meter.

L_2 = Smaller span in meter.

E = Young's Modulus in N/mm^2

$E_{aluminum} = 70,000 N/mm^2$

f = Maximum frontal deflection in mm.

H_2 = biggest height of glazing panel.

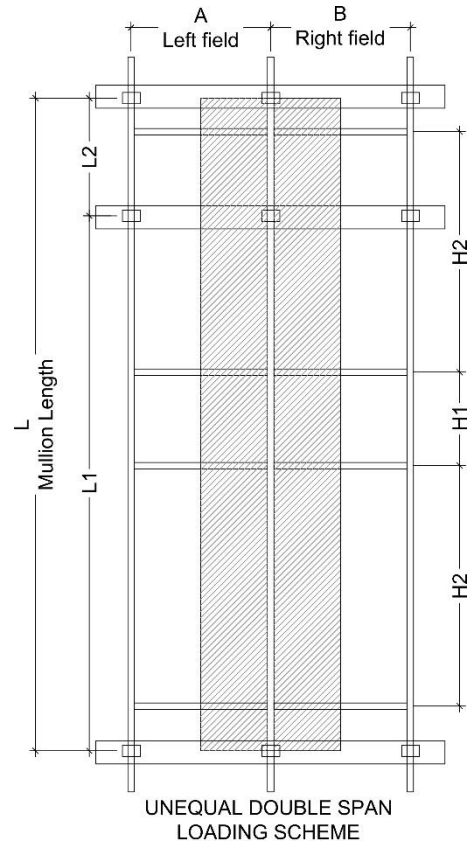

According to EN 13830, Maximum deflection should be $(L_1)/200$ or 15 mm. whichever is less with taking into account that double glazing edge deflection should not be more than 12mm. in accordance with EN 1279-5

Formula to check the glazing edge deflection:

$$R = \frac{f}{12} \left(\frac{H_2}{L_1} \right)^2 \leq 1$$

If $R > 1$ then correction factor equal to R should be multiplied to calculated I_x

Example 3:

$P = 1600 N/m^2$, $L = 6.80 m.$, $A = 1.2m.$, $B = 1.2m.$, $H_2 = 2.8 m.$, $L_1 = 5.8m.$, $L_2 = 1 m.$
 $((A+B)/2) \times p = 1920$, $f_{max} = 15mm.$

$$I_x = \frac{1920 \times 5.8^2}{384 \times 70000 \times 15} \times (9 \times 6.8 \times 5.8 - 3 \times 6.8^2 - 4 \times 5.8^2) \times 10^5 = 1308.4 cm^4$$

$$R = \frac{15}{12} \left(\frac{2.8}{5.8} \right)^2 = 0.29$$

Hence $R < 1$, No correction required.

2. Transom calculation

2.1. Wind Load

Triangular Load:

$$I_x = \frac{q \times B^4}{120 \times E \times f} \times 10^5$$

Trapezoid Load:

$$I_x = \frac{q \times B^4}{1920 \times E \times f} \times \left(25 - 40 \times \frac{a^2}{B^2} + 16 \times \frac{a^4}{B^4} \right) \times 10^5$$

Where:

I_x = Moment of inertia in cm^4

P = designed wind load in N/m^2 or Pa

B = Length in meter

For triangular Load: $q = B/2 \times p$

For trapezoid load: $q = a \times p$

a = Panel height/2 in meter

E = Young's Modulus in N/mm^2

$E_{aluminum} = 70,000 N/mm^2$

f = Maximum frontal deflection in mm. = $B/200$ or max 12mm.

d = Distance to glass support in meter, normally 0.15 m.

Example 4:

$P = 1600 N/m^2$, $B = 1.2m$, $H1 = 1.0 m$, $H2 = 2.8m$. $f_{max} = 1200/200 = 6mm$.

$$I_{x1} = \frac{960 \times 1.2^4}{120 \times 70000 \times 6} \times 10^5 = 3.95 cm^4$$

$$I_{x2} = \frac{800 \times 1.2^4}{1920 \times 70000 \times 6} \times \left(25 - 40 \times \frac{0.5^2}{1.2^2} + 16 \times \frac{0.5^4}{1.2^4} \right) \times 10^5 = 3.81 cm^4$$

$$I_x = 3.95 + 3.81 = 7.76 cm^4$$

2.2. Dead Load

Where:

I_y = Moment of inertia in cm^4

$$I_y = \frac{F \times d}{24 \times E \times f} \times (3 \times B^2 - 4 \times d^2) \times 10^5$$

F = Force in $N = 10 \times G/2$, G = glass weight in kg

B = Length in meter

E = Young's Modulus in N/mm^2 , $E_{aluminum} = 70,000 N/mm^2$

f = Maximum frontal deflection in mm. = $B/500$ or max 3mm.

d = Distance to glass support in meter, normally 0.15 m.

Example 5:

Glazing thickness = $6+16+6$, glass weight = $(6+6) \times 2.5 \times 2.8 \times 1.2 = 100.8 kg$

$$I_y = \frac{504 \times 0.15}{24 \times 70000 \times 2.4} \times (3 \times 1.2^2 - 4 \times 0.15^2) \times 10^5 = 7.93 cm^4$$

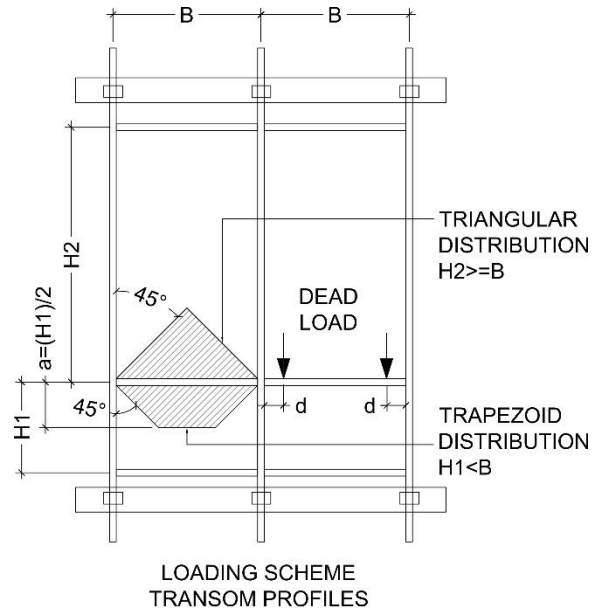

3. Load and Resistance Factor Design (LRFD)

A check must be made of the stress to which the cross-section of the profile will be subjected to ensure that the calculated stress is less than the permitted stress for the material, that is to say:

3.1. Mullion

$$\frac{M^*}{W} \leq \sigma_{adm}^*$$

Where:

M^* = Service moment calculation [m-N or Pa]

σ_{adm}^* = Permitted stress calculation [N/m²]

W = Resistance moment of section in cm³

$$M^* = \gamma_s \times M = 1.55 \times \frac{q \cdot l^2}{8}$$

Where:

$$\sigma_{adm}^* = \frac{\sigma_{adm}}{\gamma_M}$$

γ_s = Dynamic load increase coefficient = 1.55

σ_{adm} = Maximum tensile strength of 6063-T5 aluminum alloy = 140MPa

γ_M = Material decrease coefficient = 1.1

Example 6:

Loading data base on example 1

$$\sigma_{adm}^* = \frac{\sigma_{adm}}{\gamma_M} = \frac{140}{1.1} = 127.28$$

$$M^* = \gamma_s \times M = 1.55 \times \frac{q \cdot l^2}{8} = 1.55 \times \frac{1920.3.4^2}{8} = 4300.32$$

Required W_x of section = $4300.32 / 127.28 = 33.78 \text{ cm}^3$

3.2. Transom

$$\frac{M^*}{W} \leq \sigma_{adm}^*$$

Where:

M^* = Deflection moment calculation [m-N or Pa]

σ_{adm}^* = Permitted stress calculation [N/m²]

W = Resistance moment of section in cm³

$$M^* = f \cdot d$$

$$M^* = \gamma_s \times M$$

γ_s For fixed load (dead load) increase coefficient = 1.35

$F=10 \times G/2$, G = glass weight in kg

d = Distance to glass support in meter, normally 0.15 m.

4. Glazing Thickness

In this method of calculating the glazing thickness:

- The load is uniform over the whole surface of the glass.
- The maximum permitted stress (σ_{adm}) adopted must be in accordance with the type of glass to be used
- The result obtained from the calculation is the minimum thickness the glass must have.

$$e = \beta \cdot a \cdot \sqrt{\frac{Q}{\sigma_{adm}}}$$

SHAPE COEFFICIENT β			
b/a	4-side Supports	3-side Supports	2-side Supports
1.0	0.54	0.82	0.87
1.1	0.58	0.84	0.87
1.2	0.61	0.85	0.87
1.3	0.64	0.86	0.87
1.5	0.70	0.88	0.87
1.7	0.74	0.88	0.87
2.0	0.78	0.89	0.87
3.0	0.84	0.89	0.87
5.0	0.86	0.89	0.87

Where:

e = Minimum glazing thickness in mm.

β = Shape coefficient according to table

a = Shortest side of glass in mm.

b = Longest side of glass in mm.

Q = Designed wind load in [N/m²]

σ_{adm} = Permitted stress in the glass [N/m²] = 5x10⁷ N/m² (toughened glass subjected to permanent stresses)

In accordance with European Standard EN 13022-1, the equivalent thickness of a multi-pane glazing panel is calculated in the following manner:

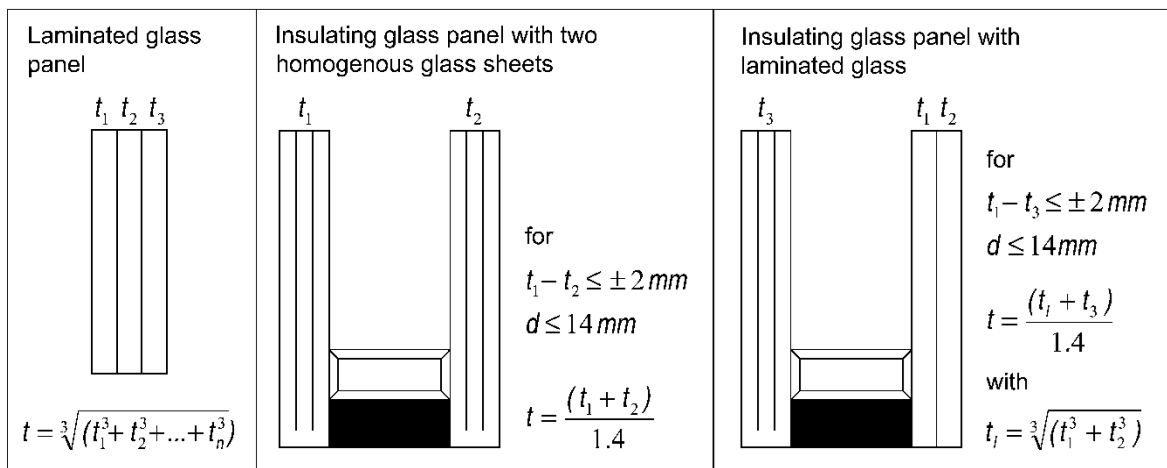

5. Non mechanical weight supported top hung opening size

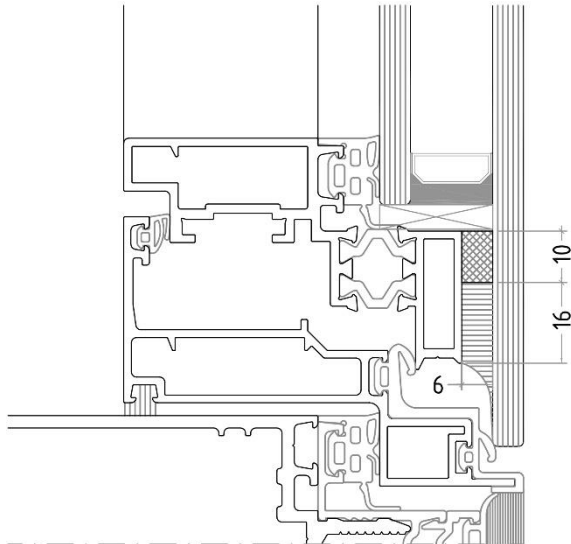

FIGURE 1
 DOUBLE SIDE ADHESIVE TAPE 6x10mm.

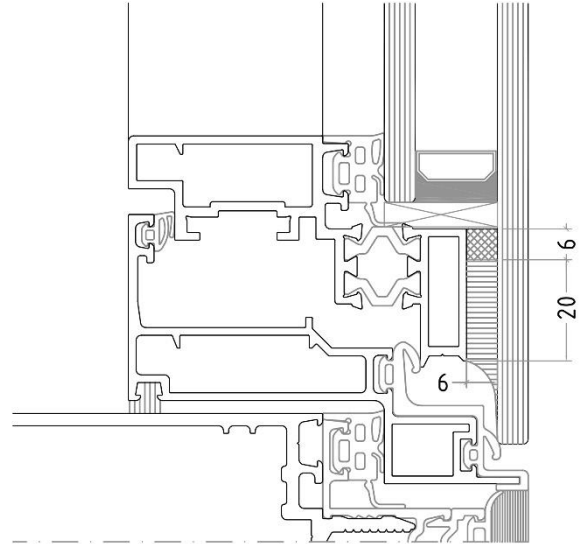
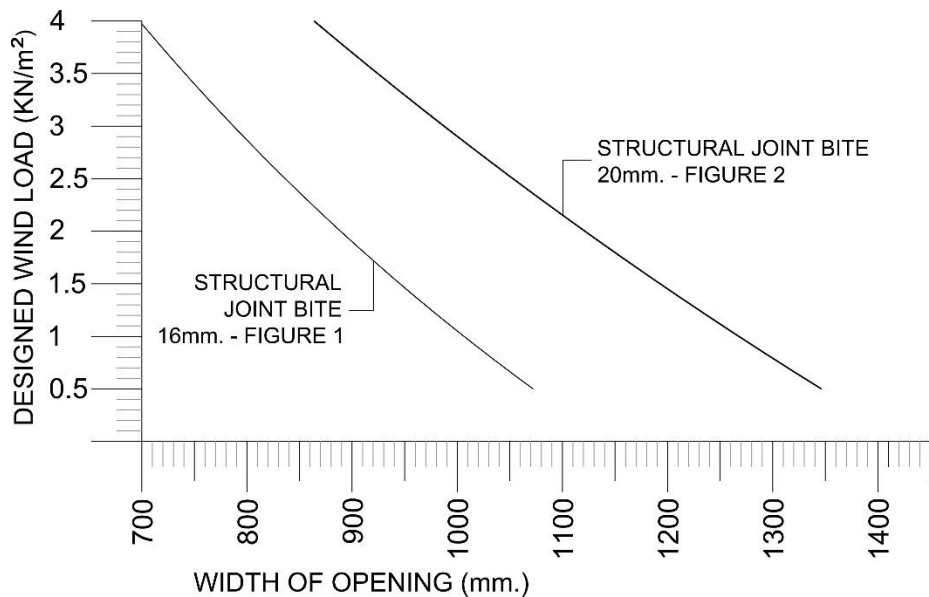

FIGURE 2
 DOUBLE SIDE ADHESIVE TAPE 6x6mm.



Notes:

- Total glazing thickness = 12mm.
- Max height of opening panel = 2500mm.
- permissible stress of the adhesive for non-supported constructions = 0.105MPa
- Maximum adhesive stress for supported constructions = 0.14MPa

HOW TO USE THE TABLES

For ascertaining moment of inertia for curtain wall mullions

Step 1: Determine the wind velocity (table 1-01)

In this example: 100km/h

Step 2: determine the building topography (Table 1-02)

In this example: Category A

Step 3: Determine the top of curtain wall height and wind Load (Table 1-03 and 1-04)

In this example 48 meter and 1167 N/m²

Step 4: Define the loading scheme (single or double span), mullion span, load width and the primary moment of inertia for mullion base on 1000 N/m² from tables 1-05 or 1-06

In this example:

Single span, mullion length = 3.6m. Load width = 1.2m. And $I_{(x, \text{primary})} = 250 \text{ cm}^4$

Step 5: calculate the required moment of inertia

$$I_x = \frac{1167}{1000} \times 250 = 291.75 \text{ cm}^4$$

Step 6: check for glazing deflection

$$R = \frac{15}{12} \left(\frac{2.8}{3.6} \right)^2 = 0.75$$

No correction required for moment of inertia of mullion.







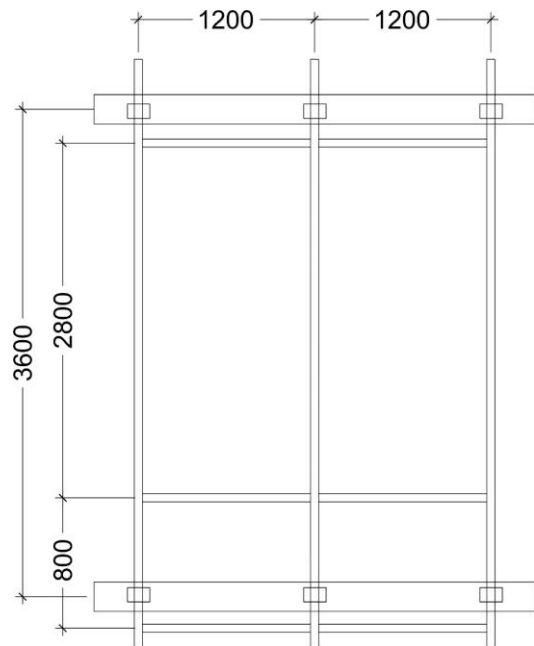











Step 7: find the compatible profile from table 1-07

In this example:



























- Profile number 1000307 with moment of inertia equal to: 334.41 cm⁴
- Profile number 1000263 with aluminum flat bar insertion: 295.93 cm⁴



PROFILES :

Number	Shape	DESCRIPTION	$I_x \text{ cm}^4$	$I_y \text{ cm}^4$
1000311		Mullion / Transom 60x60	42.33	25.33
1000312		Mullion / Transom 60x80	79.01	31.11
1000313		Mullion / Transom 60x100	132.15	37.18
1000314		Mullion / Transom 60x120	207.62	45.70
1000315		Mullion / Transom 60x140	306.44	52.54
1000316		Mullion / Transom 60x160	469.74	62.91
1000317		Mullion / Transom 60x180	637.06	73.26
1000328		Mullion / Transom 60x200	863.38	77.94
1000329		Insertion Profile	614.00	44.83
1000299		Hidden Vent Frame	47.54	4.96
1000300		Hidden Vent Sash	36.42	4.18
1000229		Curtain wall Opening Frame	–	–
3405001		Curtain wall Opening Sash	–	–
1000598		Curtain wall Parallel Opening Frame	–	–
3405002		Curtain wall Parallel Opening Sash	–	–
1000215		Pressure plate	–	–
1000216		Cover cap 12 mm	–	–
1000217		Cover cap 16 mm	–	–

PROFILES :

Number	Shape	DESCRIPTION	$I_x \text{ cm}^4$	$I_y \text{ cm}^4$
1000523		Pressure plate Inner 135 Degree	-	-
1000583		Pressure plate Outer 135 Degree	-	-
1000584		Cover cap Outer 135 Degree	-	-
1000219		Cover cap 160 mm	-	-
1000332		Cover cap 50 mm	-	-
1000218		Cover cap 150 mm	-	-
1000306		Cover cap 120 mm	-	-
1000331		Corner Adaptor Profile	-	-
1000362		Corner Adaptor Profile	-	-
1000363		Corner Adaptor Profile	-	-
1000361		Curtain wall adaptor	-	-
1000333		Structural silicon adaptor	-	-
1000173		Pressure plate holder Profile	-	-
5268100		Glazing support	-	-
5460100		Opening Glazing support	-	-
5623100		Opening Glazing support	-	-
5223060		Glass holder - SG	-	-
5222200		Glass U-channel - SG	-	-
5296030		Fixing plate	-	-
1000240		Expansion Joint Profile	-	-
1000198		Mullion / Transom Connector	-	-
1000428		Mullion / Transom Connector	-	-
1000295		Late Installation Connector Base	-	-
1000298		Late Installation Connector	-	-
1000294		45-90 Degree Connector	-	-
5210120		Brackets	-	-

ACCESSORIES :

Number	Shape	DESCRIPTION	Number	Shape	DESCRIPTION
7001017		Inner glazing gasket 12mm	7001035		Separator gasket
7001019		Glazing gasket transom	7001036		Central gasket
7001018		Pressure plate gasket	7001037		Filling Silicon gasket
7001027		Outer Corner gasket	7001003		Stop Gasket
7001020		Silicon seam gasket	7201001		PA foam gasket
7001087		Silicon seam gasket 6mm	7801001		Transom gasket piece
7001025		SG U.channel gasket	7801005		Pressure plate end gasket
7001041		Inner glazing gasket 10mm	7801006		Expansion joint gasket
7001044		Inner glazing gasket 4mm	7501007		Insulator mullion
7001071		Inner glazing gasket 6mm	7501008		Add on insulator
7001063		Inner glazing gasket 6mm	7501010		Insulator transom
7001064		Inner glazing gasket 135 Degree			
7001074		Opening frame sealing gasket			
7001075		Opening frame sealing gasket cover cap			
7001077		Opening frame sealing gasket SG			
7001040		Stop gasket			

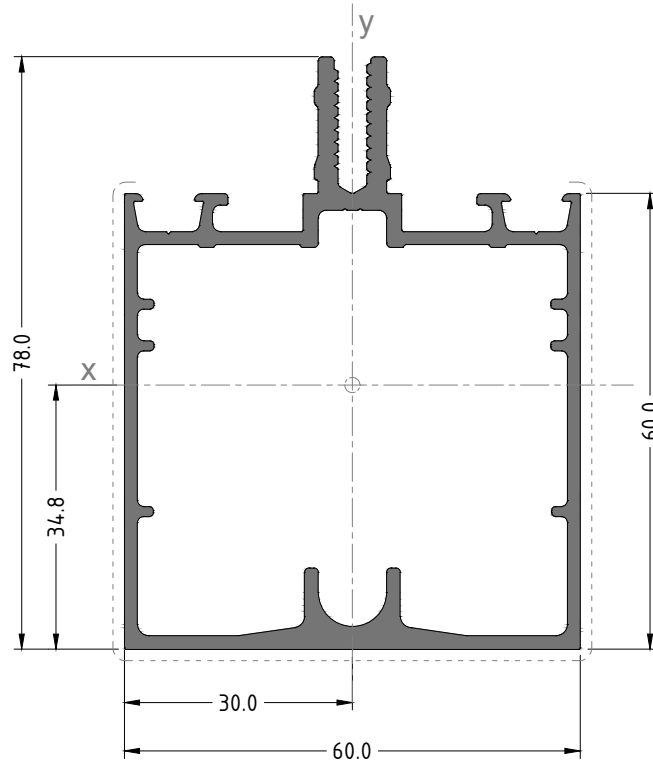

DESCRIPTION	Number	$I_x \text{ cm}^4$	$I_y \text{ cm}^4$	$e_x \text{ cm}$	$e_y \text{ cm}$	$W_x \text{ cm}^3$	$W_y \text{ cm}^3$
Mullion / Transom 60	1000311	42.33	25.33	3	3.48	9.79	8.44

Steel Insertion
50x40

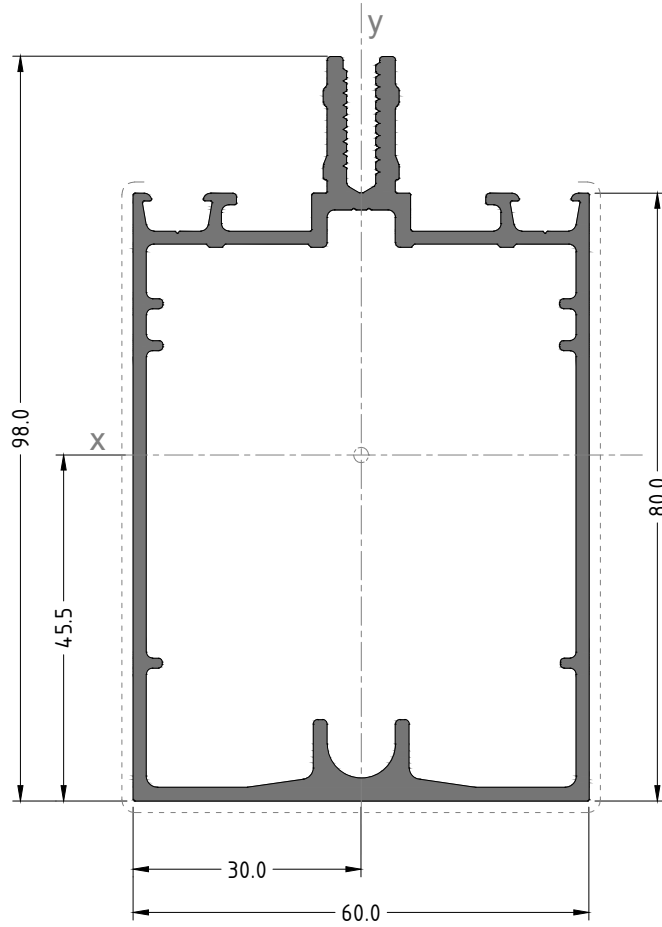

DESCRIPTION	Number	$I_x \text{ cm}^4$	$I_y \text{ cm}^4$	$e_x \text{ cm}$	$e_y \text{ cm}$	$W_x \text{ cm}^3$	$W_y \text{ cm}^3$
Mullion / Transom 80	1000312	79.01	31.11	3	4.55	15.06	10.37

Steel Insertion

50x60

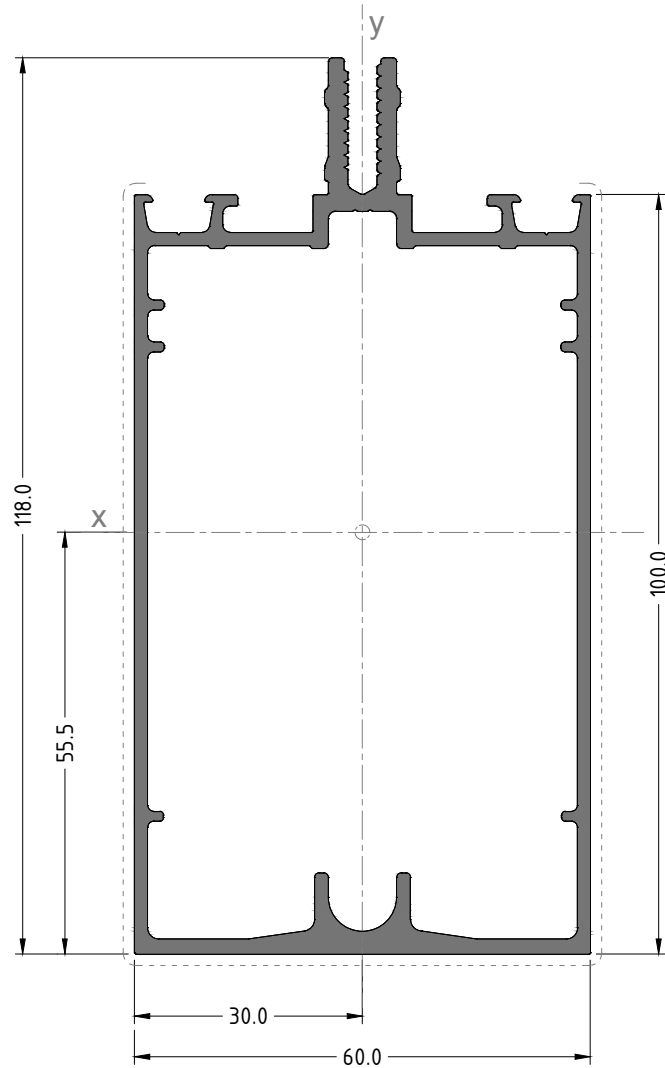

DESCRIPTION	Number	$I_x \text{ cm}^4$	$I_y \text{ cm}^4$	$e_x \text{ cm}$	$e_y \text{ cm}$	$W_x \text{ cm}^3$	$W_y \text{ cm}^3$
Mullion / Transom 100	1000313	132.15	37.18	3	5.55	21.15	12.39

Steel Insertion
50x80

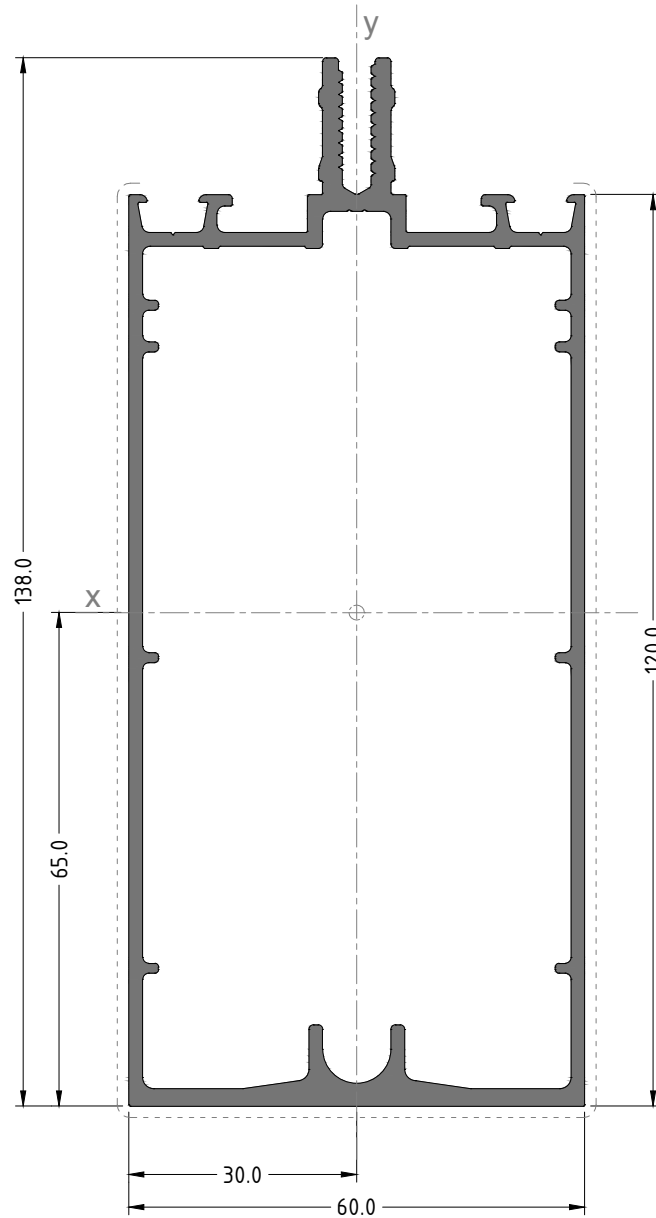

DESCRIPTION	Number	$I_x \text{ cm}^4$	$I_y \text{ cm}^4$	$e_x \text{ cm}$	$e_y \text{ cm}$	$W_x \text{ cm}^3$	$W_y \text{ cm}^3$
Mullion / Transom 120	1000314	207.62	45.70	3	6.5	28.43	15.23

Steel Insertion

50x100

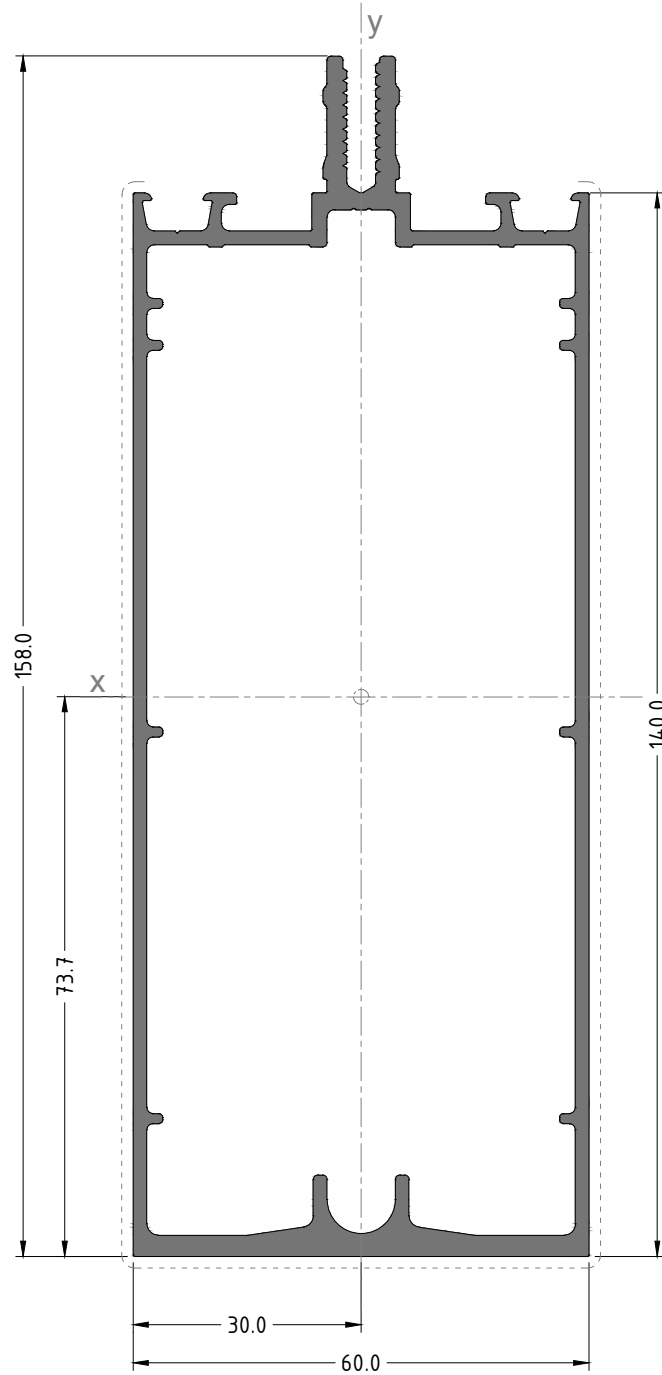

DESCRIPTION	Number	$I_x \text{ cm}^4$	$I_y \text{ cm}^4$	$e_x \text{ cm}$	$e_y \text{ cm}$	$W_x \text{ cm}^3$	$W_y \text{ cm}^3$
Mullion / Transom 140	1000315	306.44	52.54	3	7.37	36.34	17.51

Steel Insertion

50x120

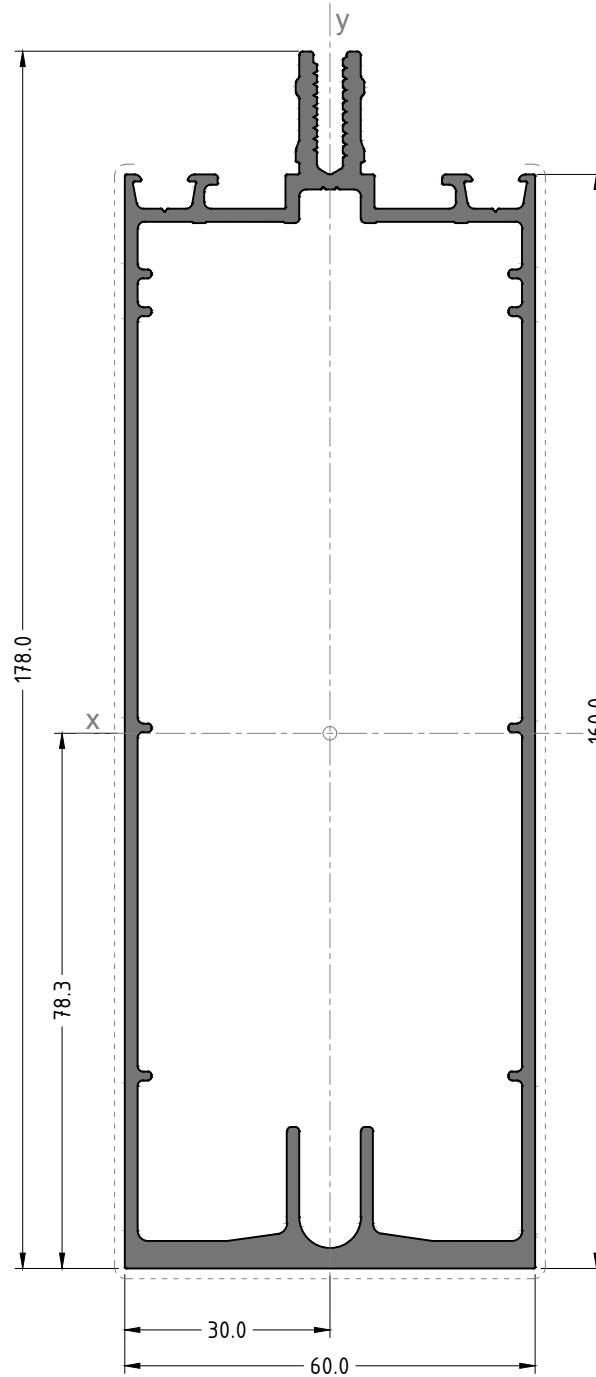

DESCRIPTION	Number	$I_x \text{ cm}^4$	$I_y \text{ cm}^4$	$e_x \text{ cm}$	$e_y \text{ cm}$	$W_x \text{ cm}^3$	$W_y \text{ cm}^3$
Mullion / Transom 160	1000316	469.74	62.91	3	7.83	47.10	20.97

Steel Insertion
50x130

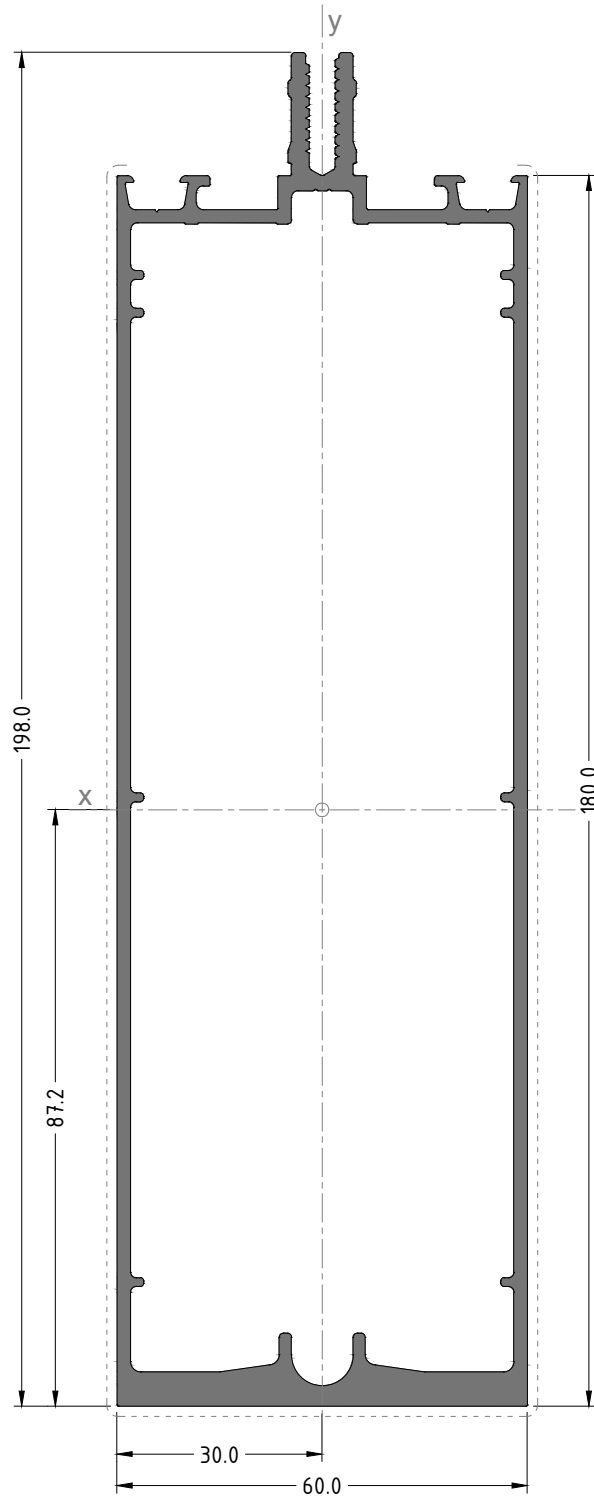

DESCRIPTION	Number	$I_x \text{ cm}^4$	$I_y \text{ cm}^4$	$e_x \text{ cm}$	$e_y \text{ cm}$	$W_x \text{ cm}^3$	$W_y \text{ cm}^3$
Mullion / Transom 180	1000317	637.06	73.26	3	8.72	57.51	24.42

Steel Insertion

50x160

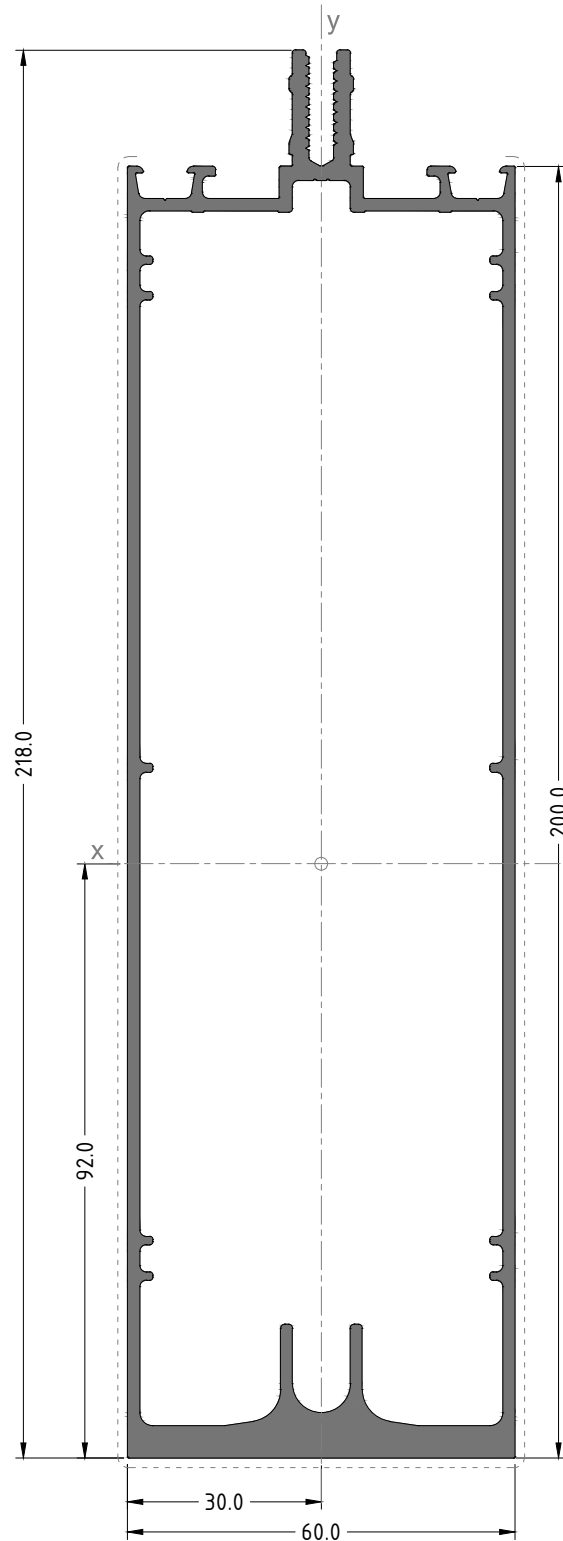

DESCRIPTION	Number	$I_x \text{ cm}^4$	$I_y \text{ cm}^4$	$e_x \text{ cm}$	$e_y \text{ cm}$	$W_x \text{ cm}^3$	$W_y \text{ cm}^3$
Mullion / Transom 200	1000328	863.38	77.94	3	9.20	68.53	25.98

Steel Insertion
50x170

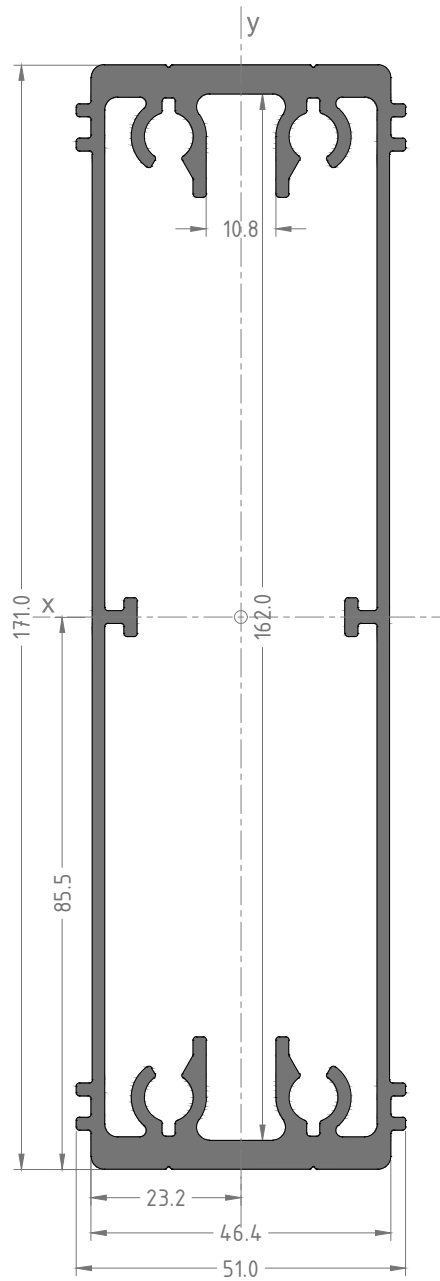

DESCRIPTION	Number	$I_x \text{ cm}^4$	$I_y \text{ cm}^4$	$e_x \text{ cm}$	$e_y \text{ cm}$	$W_x \text{ cm}^3$	$W_y \text{ cm}^3$
Insertion Profile	1000329	614.00	44.83	2.3	8.5	71.81	17.58

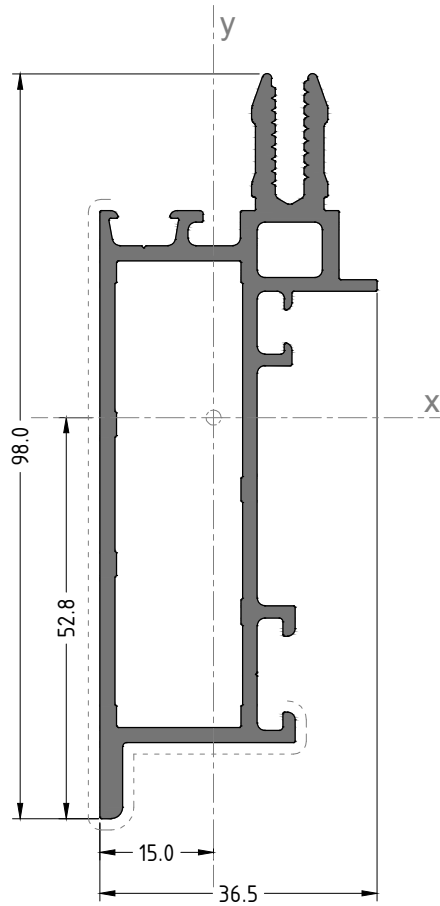

DESCRIPTION	Number	$I_x \text{ cm}^4$	$I_y \text{ cm}^4$	$e_x \text{ cm}$	$e_y \text{ cm}$	$W_x \text{ cm}^3$	$W_y \text{ cm}^3$
Hidden Vent Frame	1000299	47.54	4.96	1.5	5.28	10.51	2.30

Corner Nail / Crimp

5301610

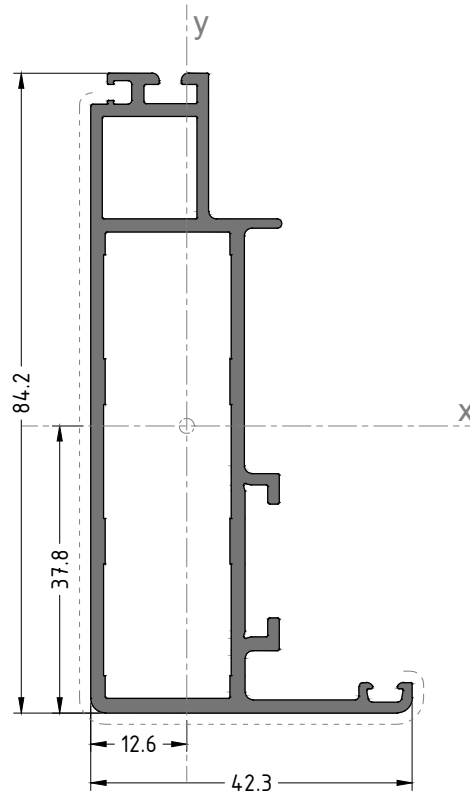

DESCRIPTION	Number	$I_x \text{ cm}^4$	$I_y \text{ cm}^4$	$e_x \text{ cm}$	$e_y \text{ cm}$	$W_x \text{ cm}^3$	$W_y \text{ cm}^3$
Hidden Vent Sash	1000300	36.42	4.18	12.6	37.8	7.84	1.41

Corner Nail / Crimp

5301610

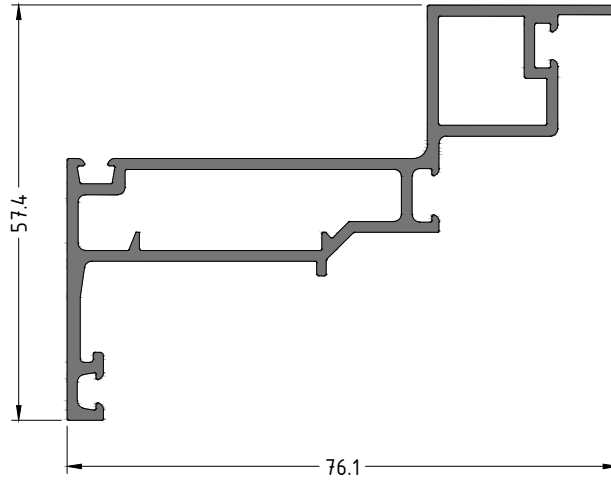

DESCRIPTION	Number	Corner Nail / Crimp
Curtain wall Opening Frames	1000229	5387248

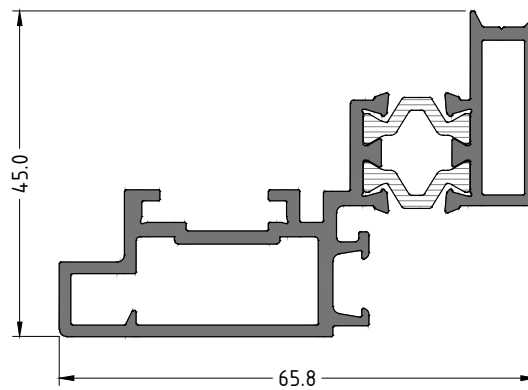

DESCRIPTION	Number	Corner Nail / Crimp
Curtain wall Opening Sash	3405001	5387248

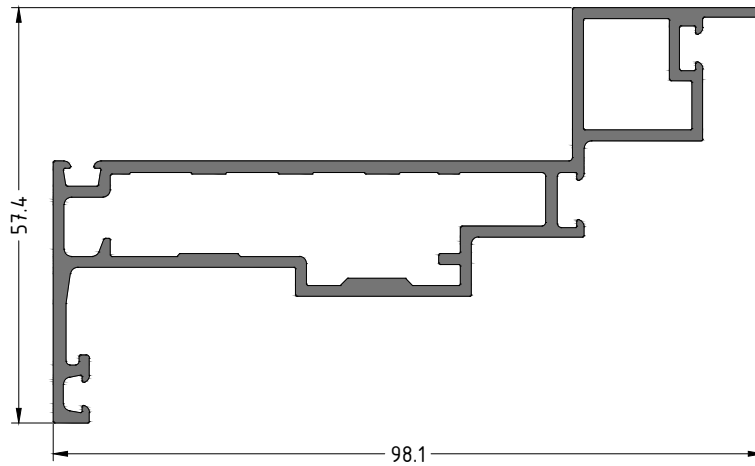

DESCRIPTION	Number	Corner Nail / Crimp
Curtain wall Parallel Opening Frames	1000598	5387480

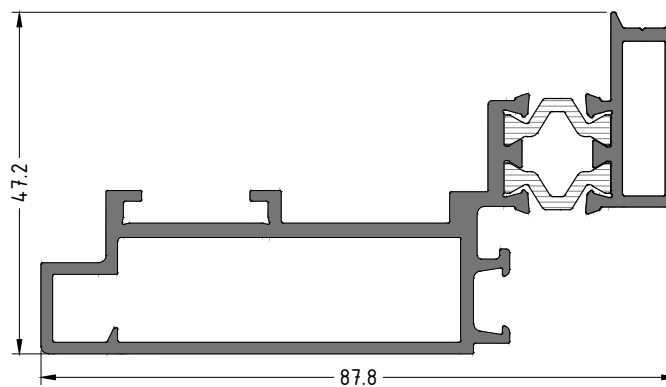

DESCRIPTION	Number	Corner Nail / Crimp
Curtain wall Parallel Opening Sash	3405002	5514470

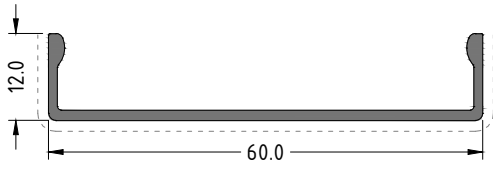

DESCRIPTION	Number
Cover cap 12 mm	1000216

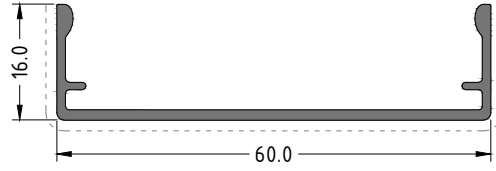

DESCRIPTION	Number
Cover cap 16 mm	1000217

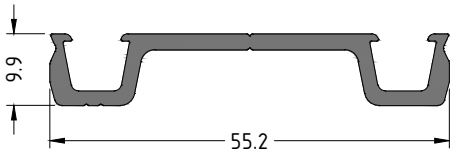

DESCRIPTION	Number
Pressure plate	1000215

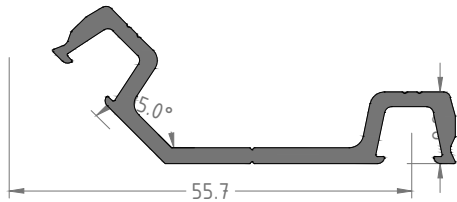

DESCRIPTION	Number
Pressure plate Outer 135 Degree	1000583

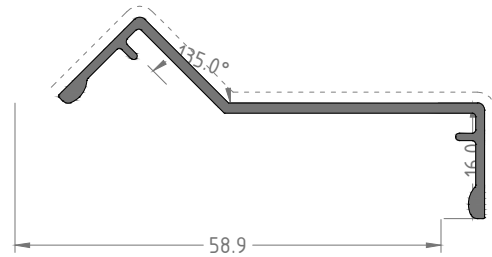

DESCRIPTION	Number
Cover cap Outer 135 Degree	1000584

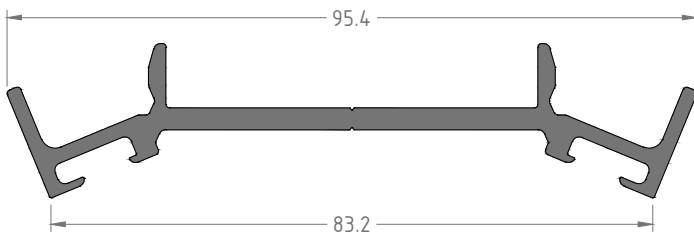

DESCRIPTION	Number
Pressure plate Inner 135 Degree	1000523

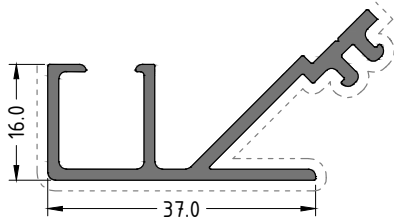

DESCRIPTION	Number
Corner Adaptor Profile	1000331

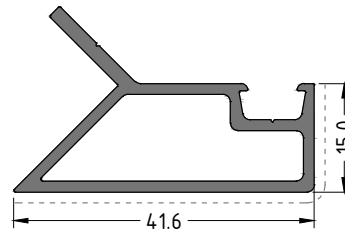

DESCRIPTION	Number
Corner Adaptor Profile	1000362

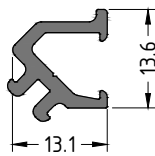

DESCRIPTION	Number
Corner Adaptor Profile	1000363

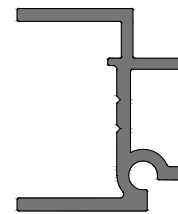

DESCRIPTION	Number
Curtain wall adaptor	1000361

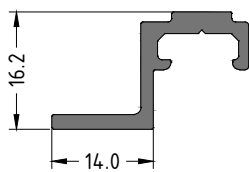

DESCRIPTION	Number
Pressure plate holder Profile	1000173

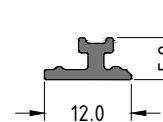

DESCRIPTION	Number
Structural silicon adaptor	1000333

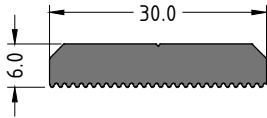

DESCRIPTION	Number
Fixing plate	5296030

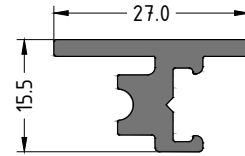

DESCRIPTION	Number
Glazing support	5268100

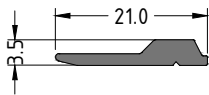

DESCRIPTION	Number
Opening Glazing support	5460100

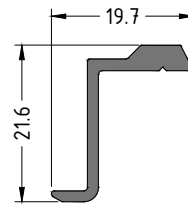

DESCRIPTION	Number
Opening Glazing support	5623100

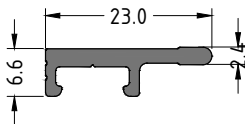

DESCRIPTION	Number
Glass holder - SG	5223060

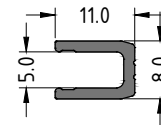

DESCRIPTION	Number
Glass U-channel - SG	5222200

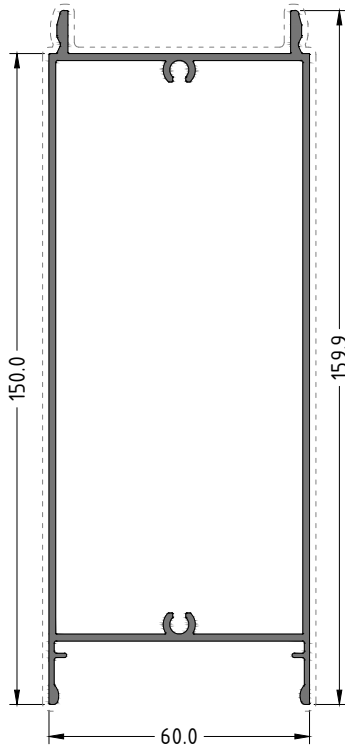

DESCRIPTION	Number
Cover cap 160 mm	1000219

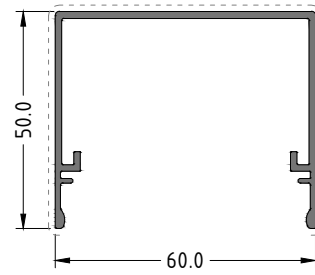

DESCRIPTION	Number
Cover cap 50 mm	1000332

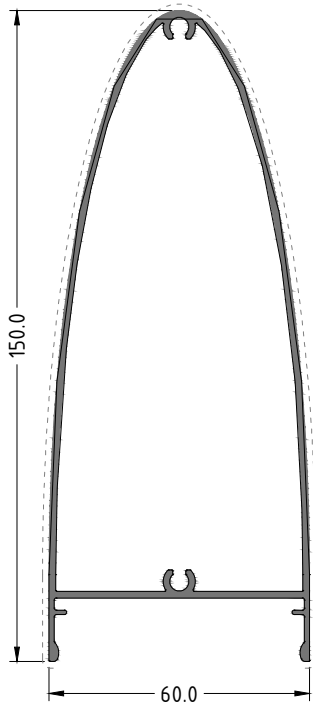

DESCRIPTION	Number
Cover cap 150 mm	1000218

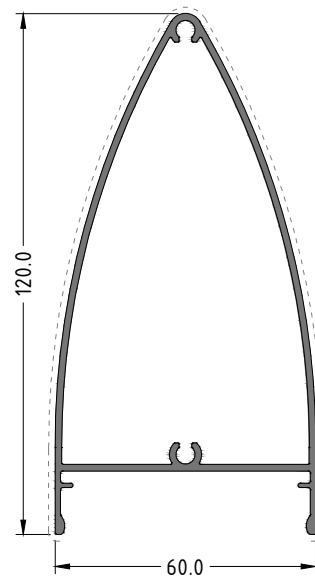

DESCRIPTION	Number
Cover cap 120 mm	1000306

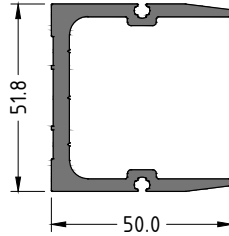

Mullion / Transom Connector

Usable with	Number	Length
1000311	5198040	40
1000312	5198060	60
1000313	5198080	80
1000314	5198100	100
1000315	5198120	120
1000316	5198130	130
1000317	5198160	160
1000328	5198170	170

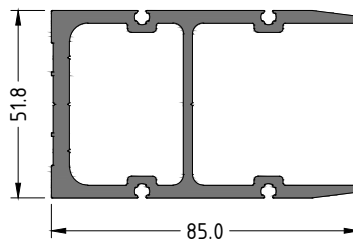

Expansion Joint Profile

Usable with	Number	Length
1000311	5428040	40
1000312	5428060	60
1000313	5428080	80
1000314	5428100	100
1000315	5428120	120
1000316	5428130	130
1000317	5428160	160
1000328	5428170	170

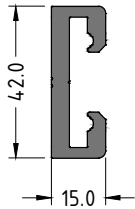

Late Installation Connector Base

Usable with	Number	Length
1000311	5295040	40
1000312	5295060	60
1000313	5295080	80
1000314	5295100	100
1000315	5295120	120
1000316	5295130	130
1000317	5295160	160
1000328	5295170	170

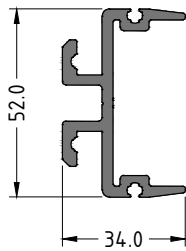

Late Installation Connector

Usable with	Number	Length
1000311	5298040	40
1000312	5298060	60
1000313	5298080	80
1000314	5298100	100
1000315	5298120	120
1000316	5298130	130
1000317	5298160	160
1000328	5298170	170

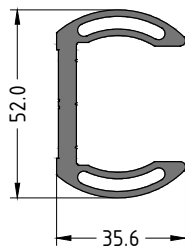

45-90 Degree Connector

Usable with	Number	Length
1000311	5294040	40
1000312	5294060	60
1000313	5294080	80
1000314	5294100	100
1000315	5294120	120
1000316	5294130	130
1000317	5294160	160
1000328	5294170	170

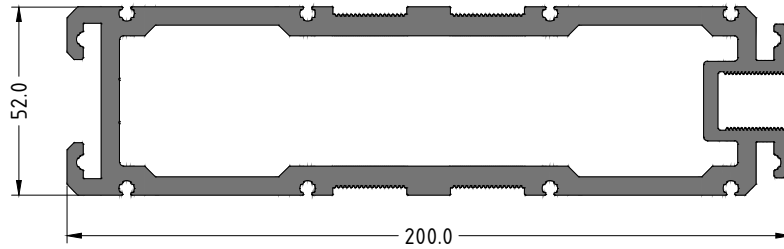

Expansion Joint Profile

Usable with	Number	Length
1000311	5240040	40
1000312	5240060	60
1000313	5240080	80
1000314	5240100	100
1000315	5240120	120
1000316	5240130	130
1000317	5240160	160
1000328	5240170	170

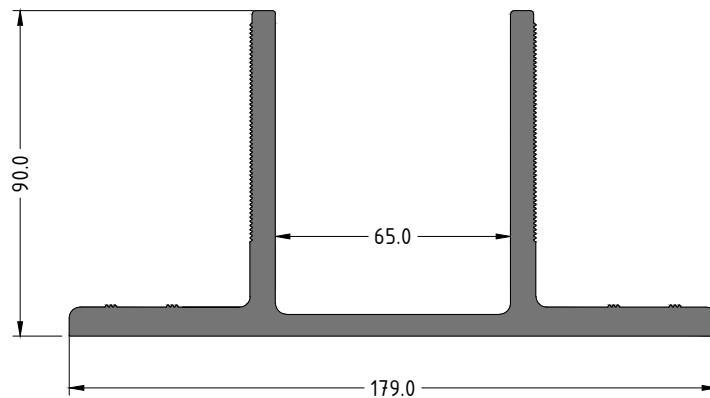

DESCRIPTION	Number
Brackets	5210120

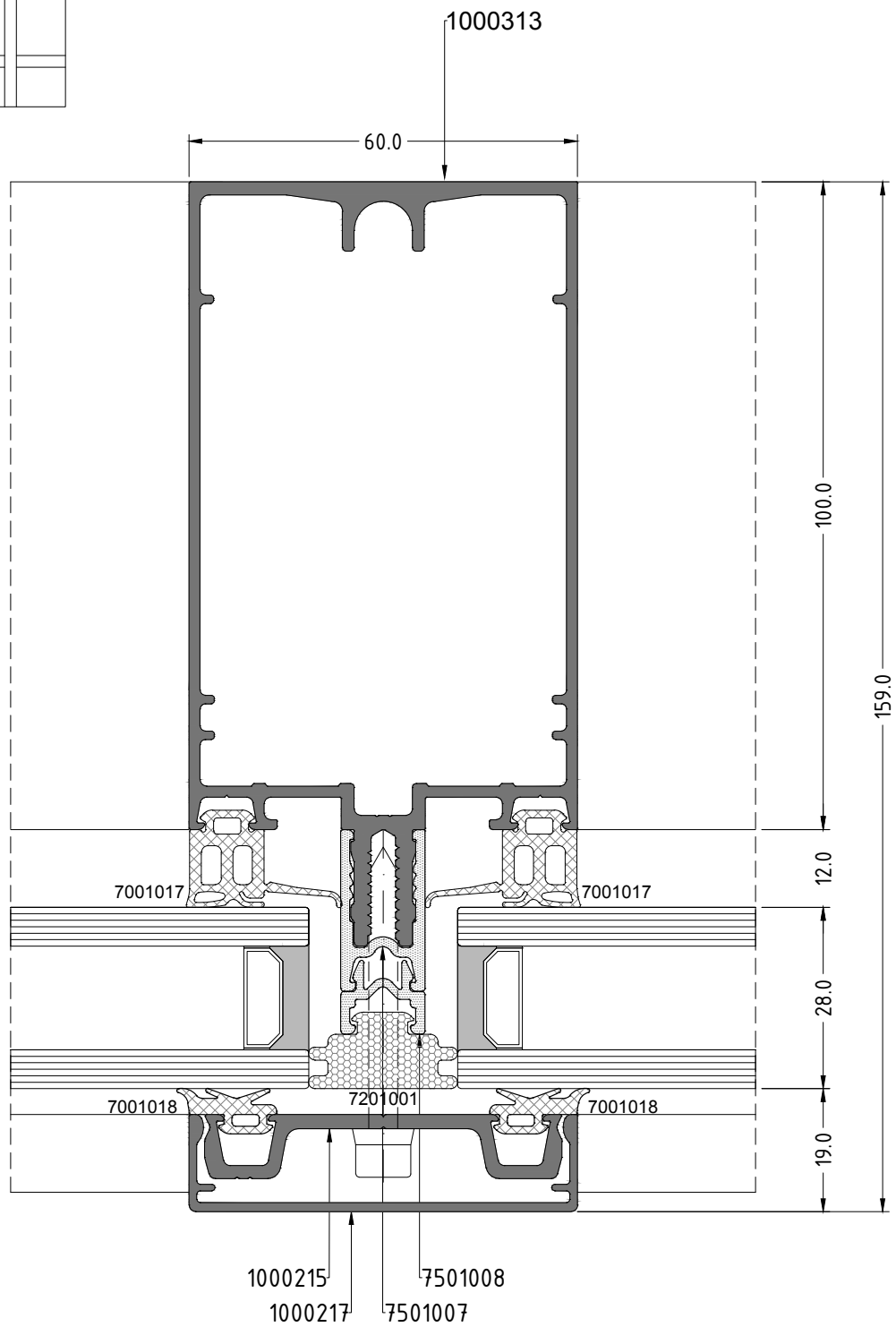
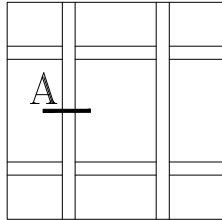

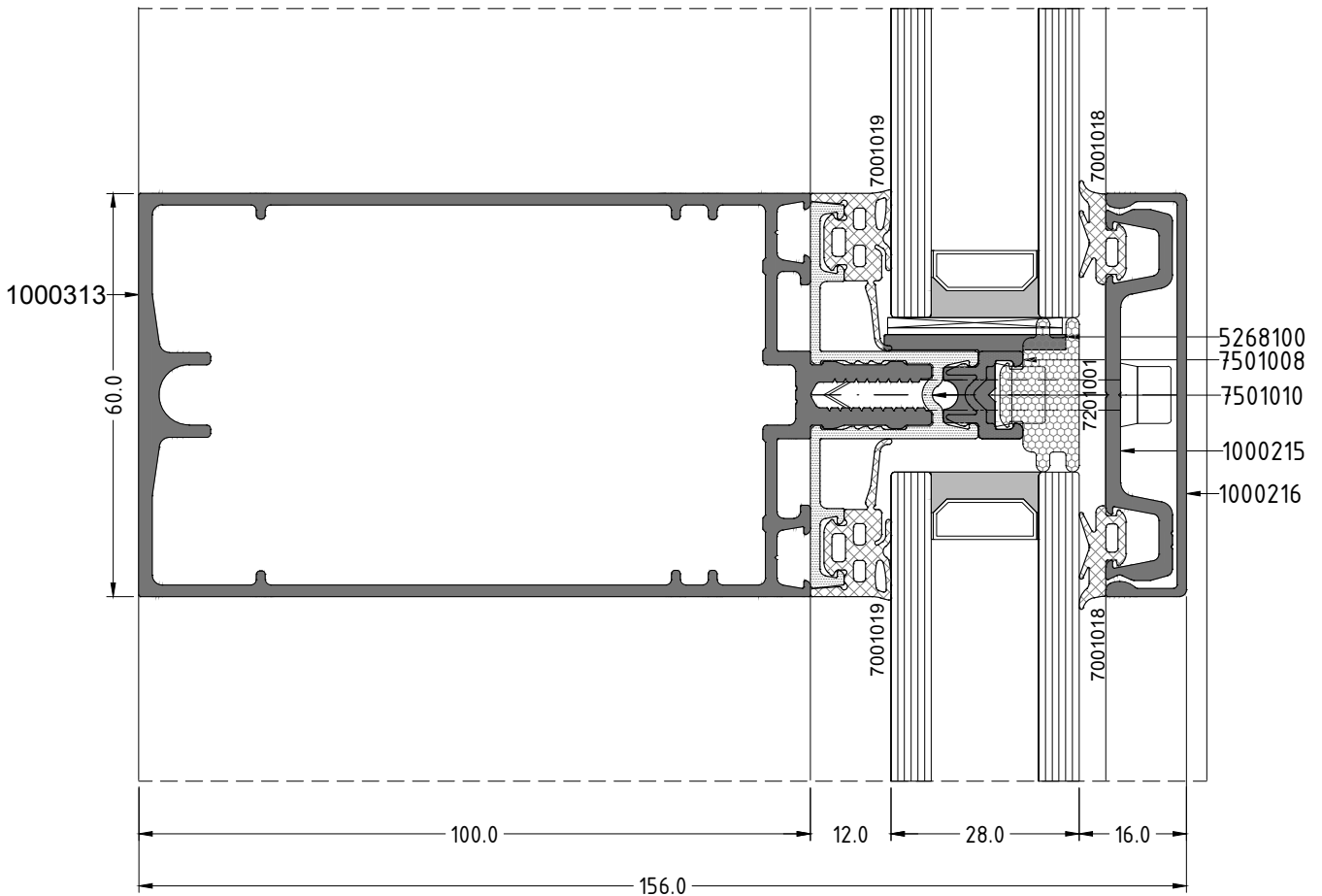
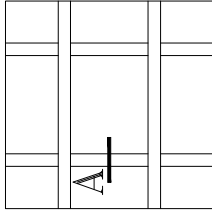

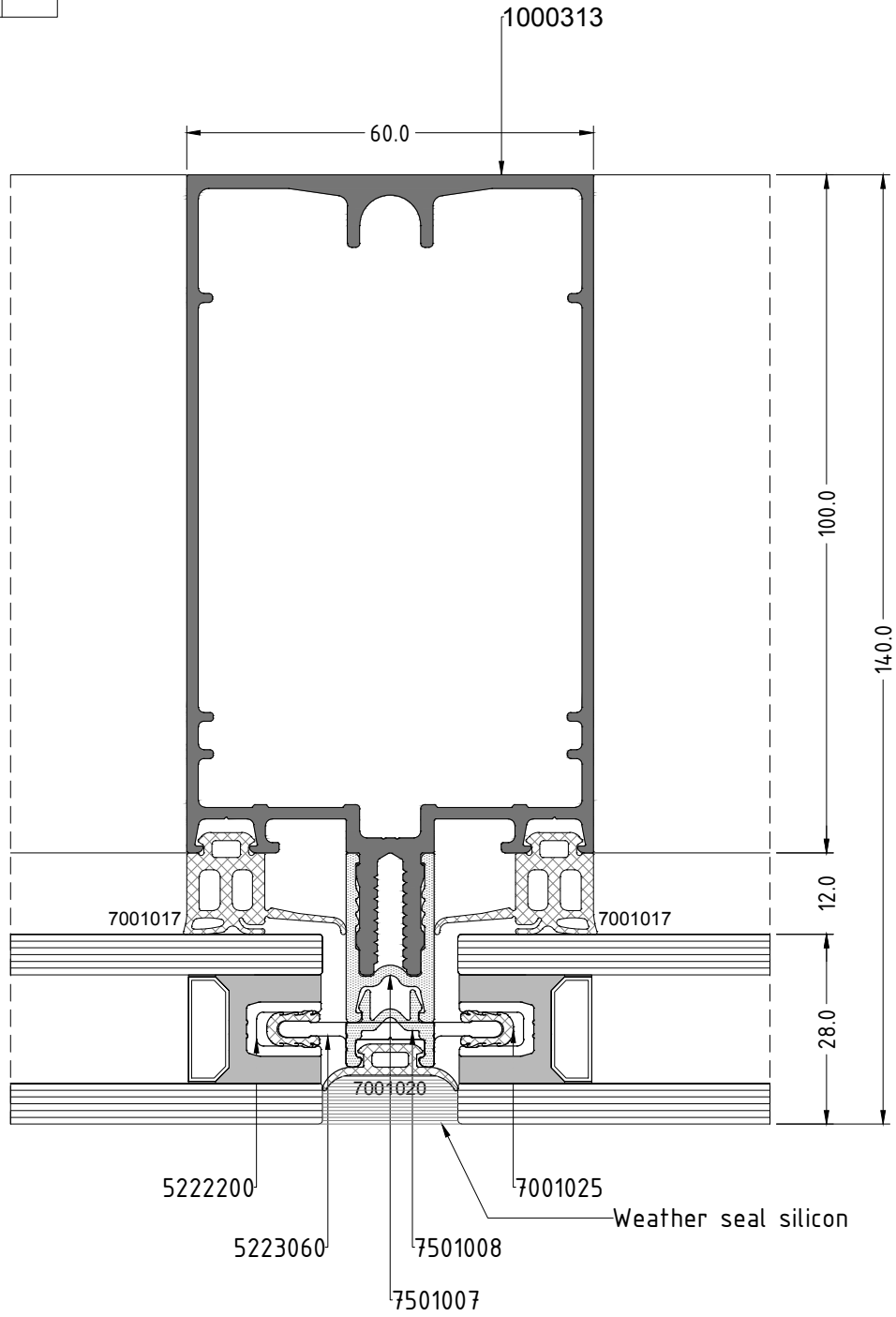
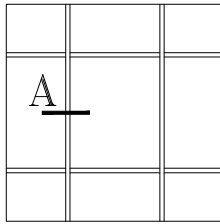

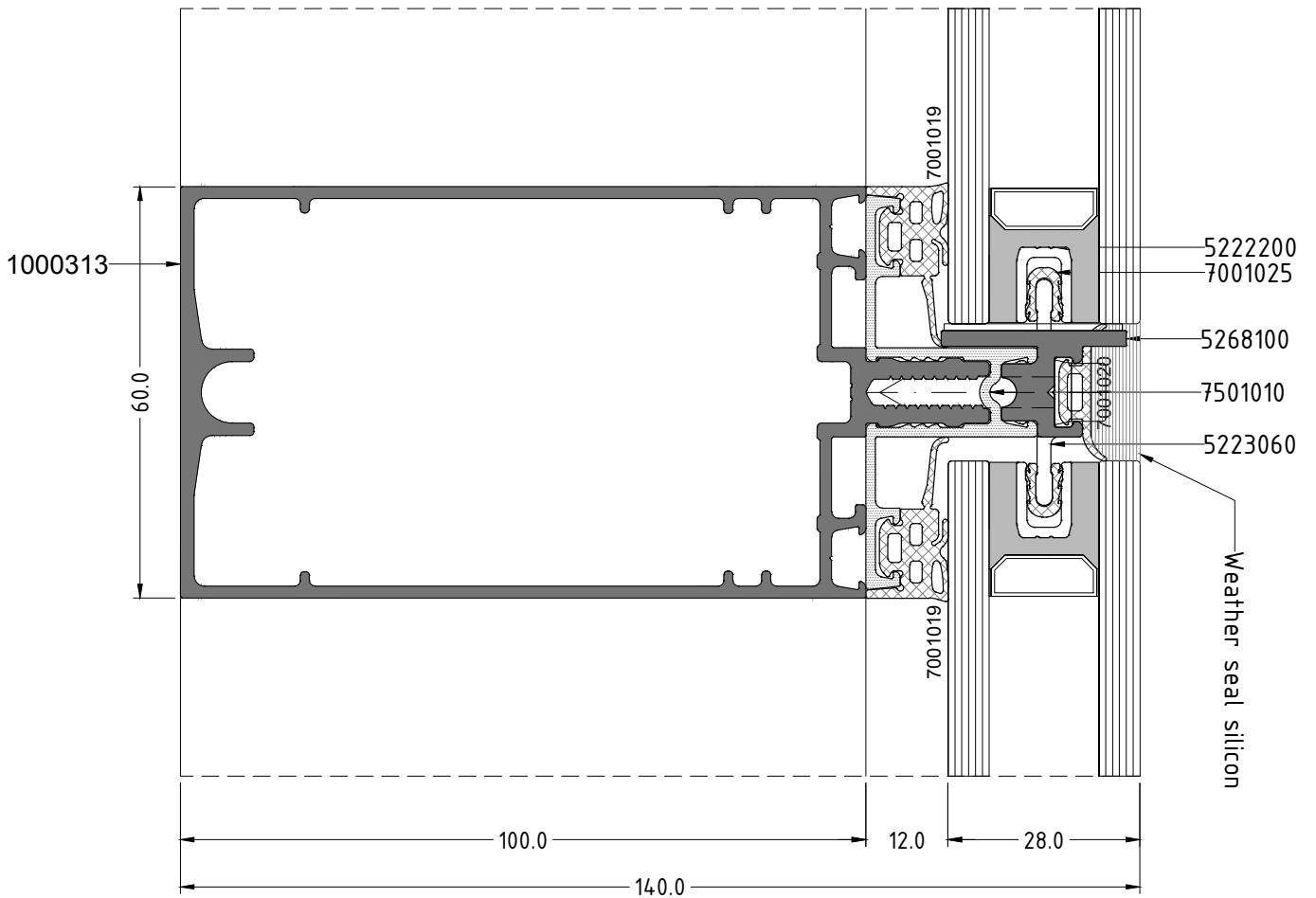
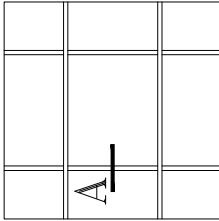

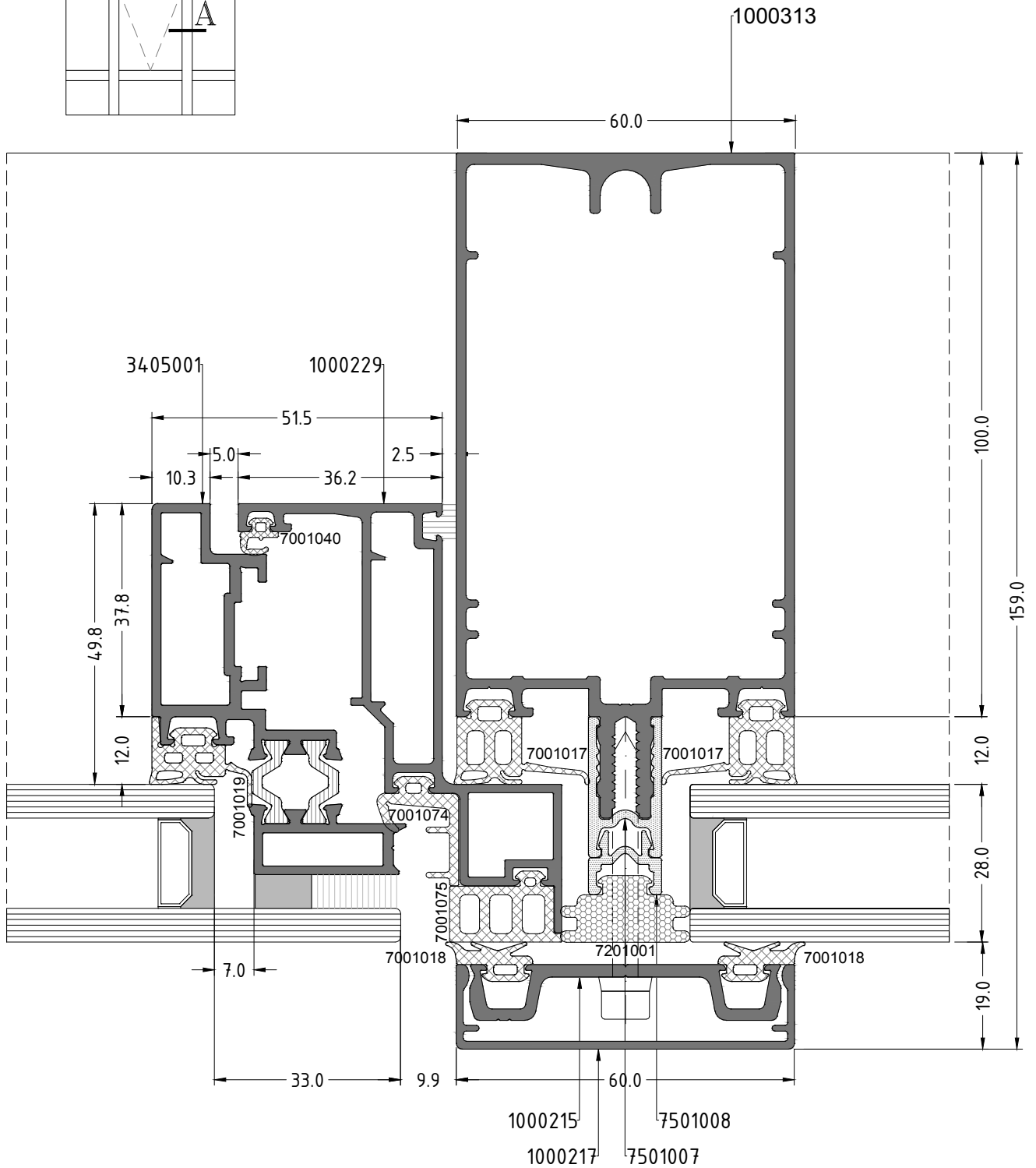
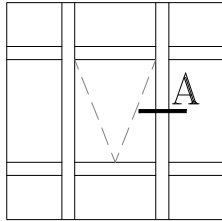

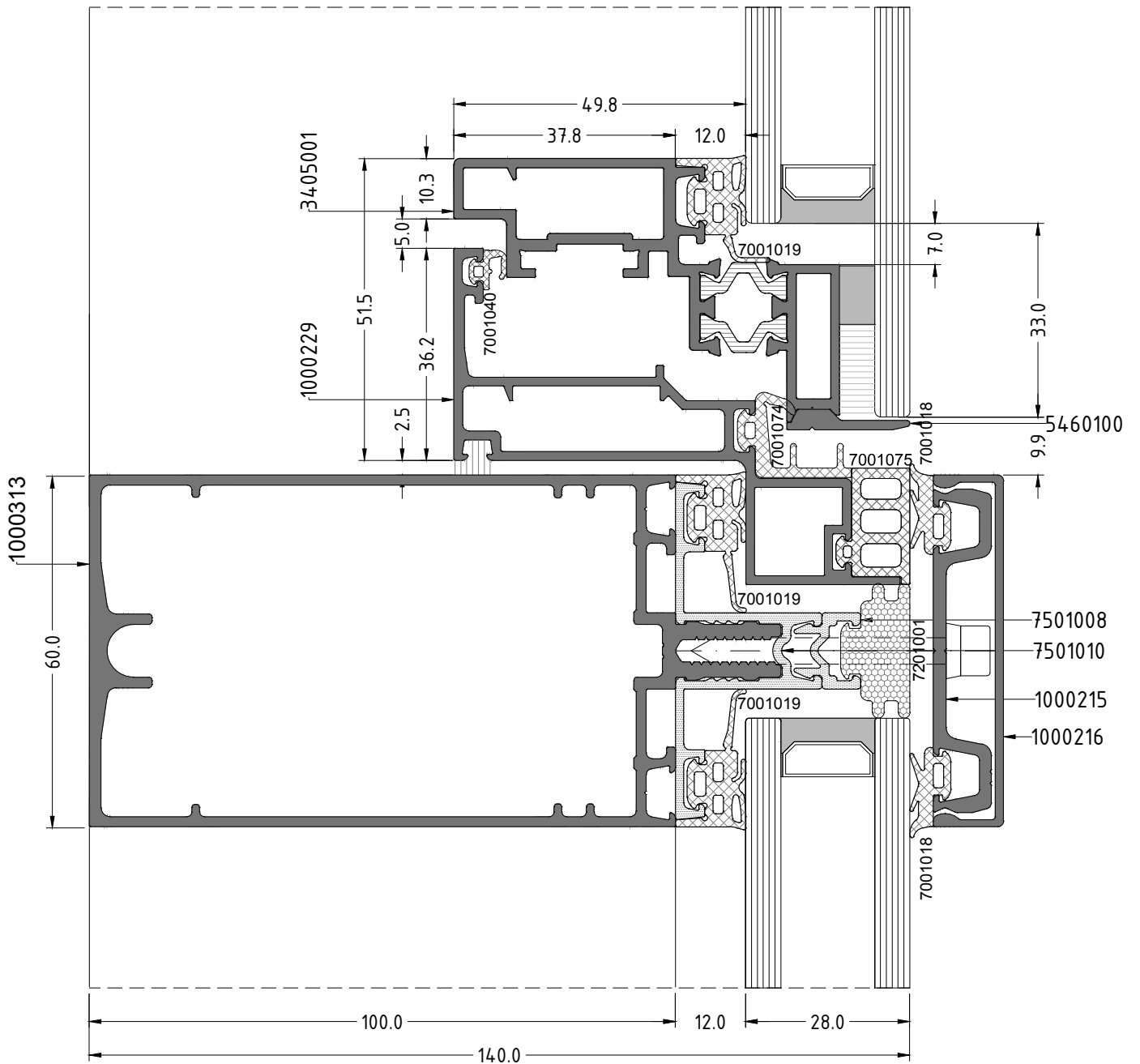
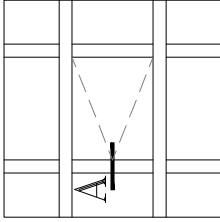

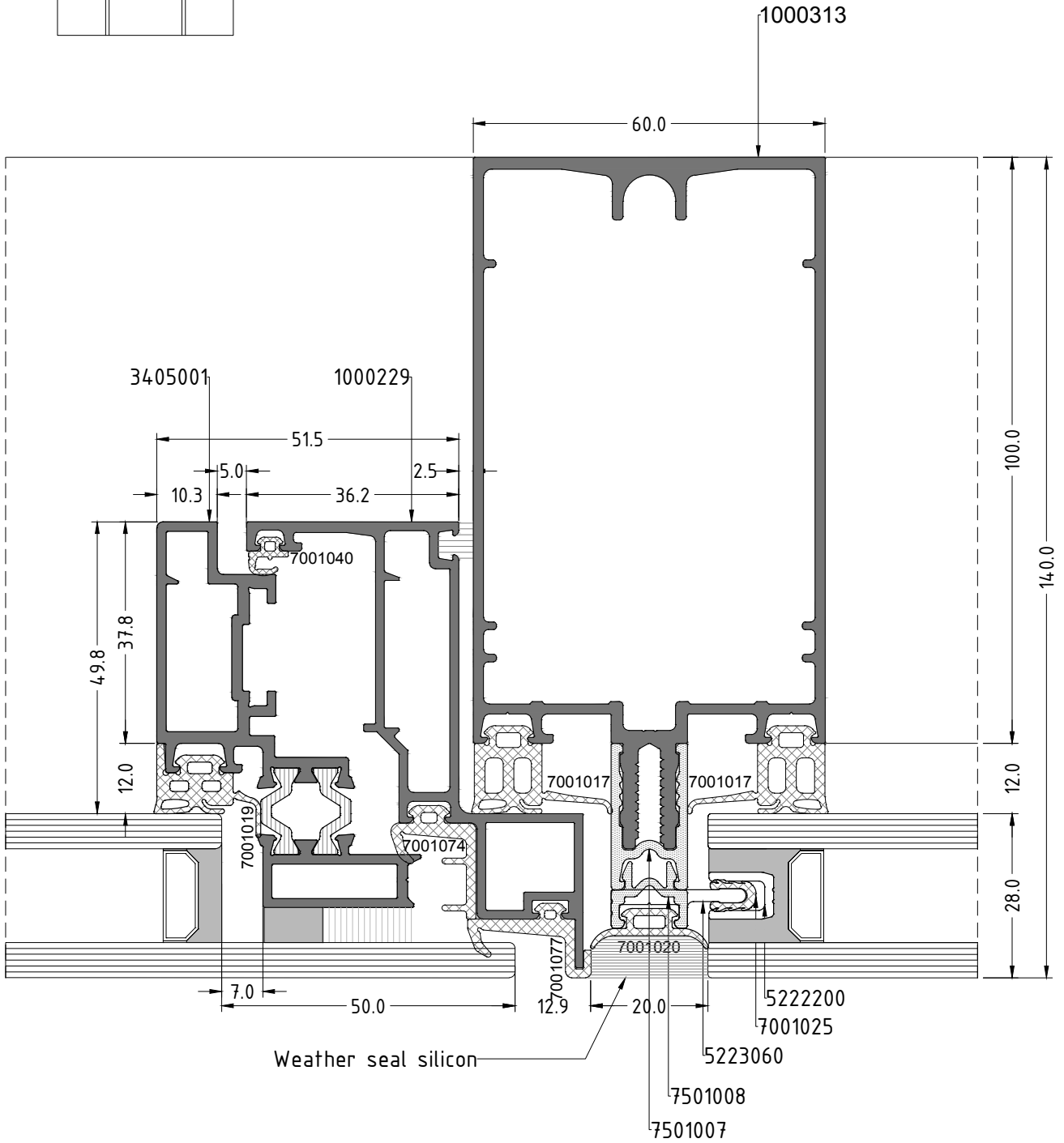
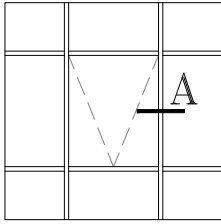

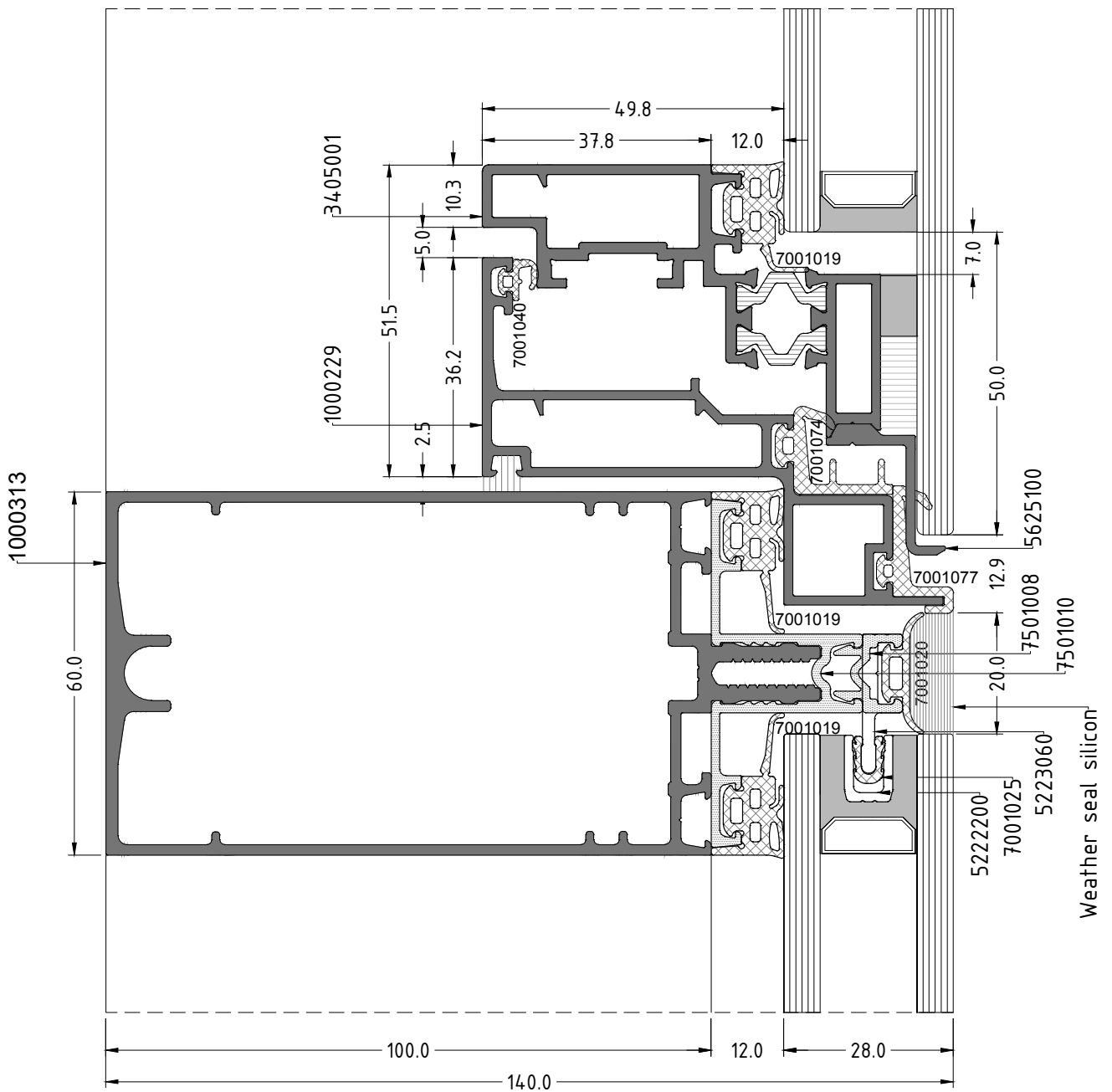
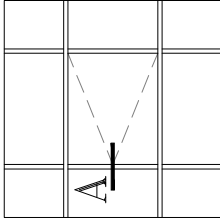

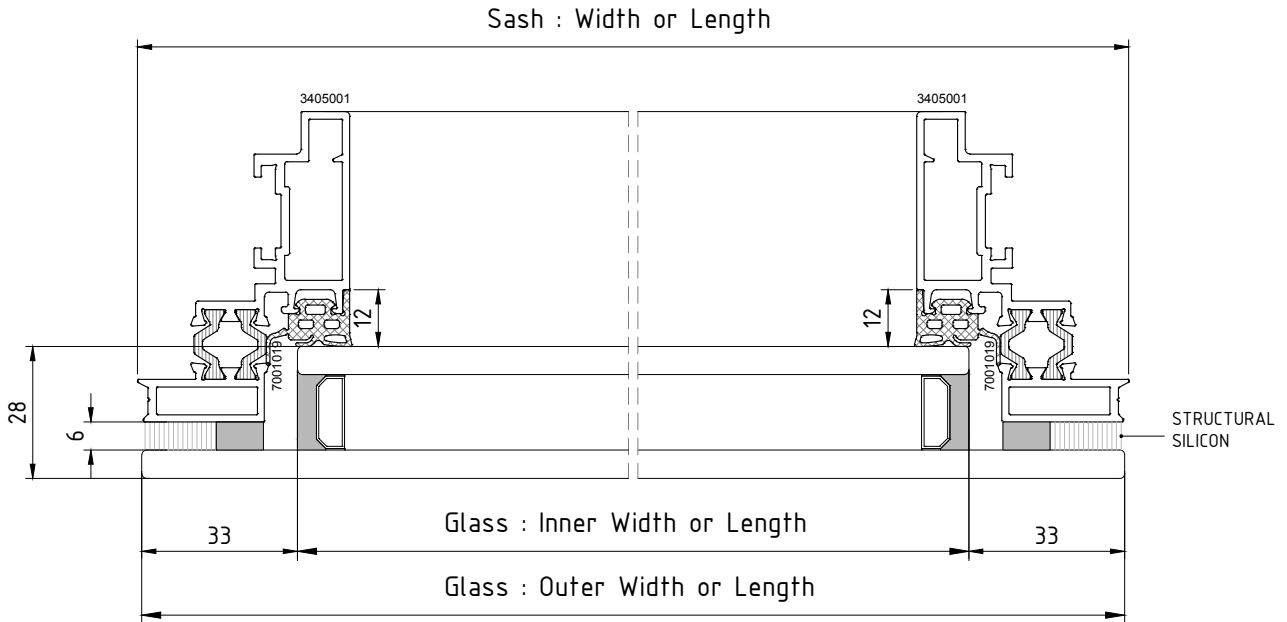

Cover cap curtain wall Outward opening . Sash glazing detail

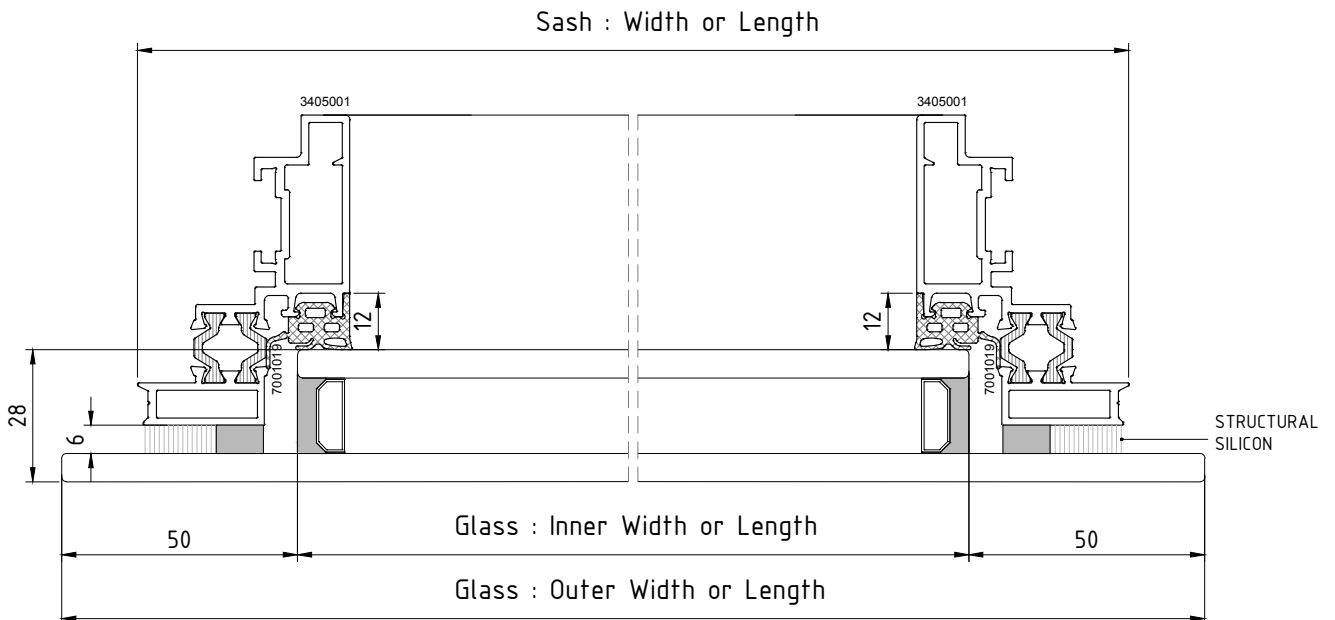

SG glazing curtain wall Outward opening . Sash glazing detail

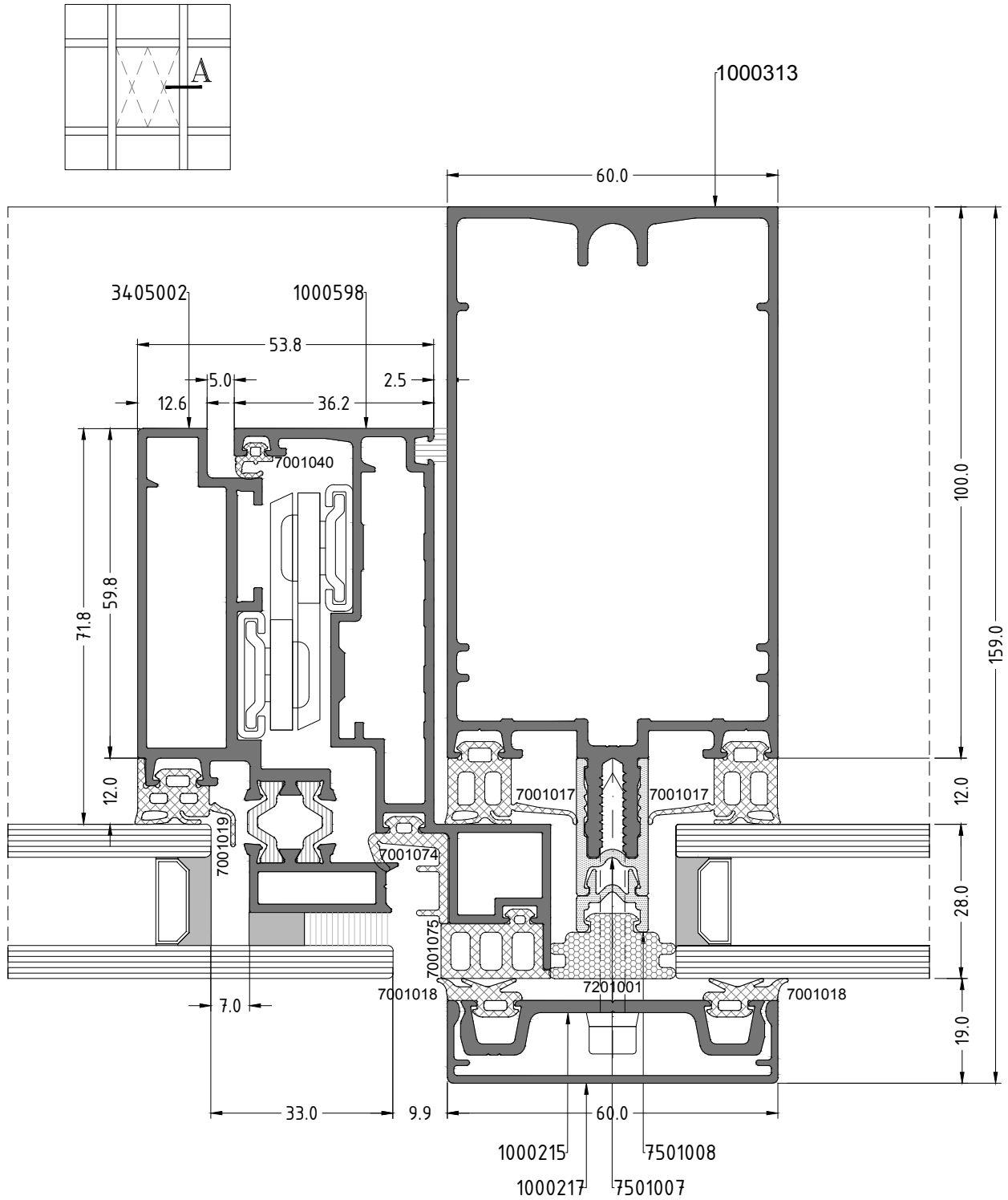

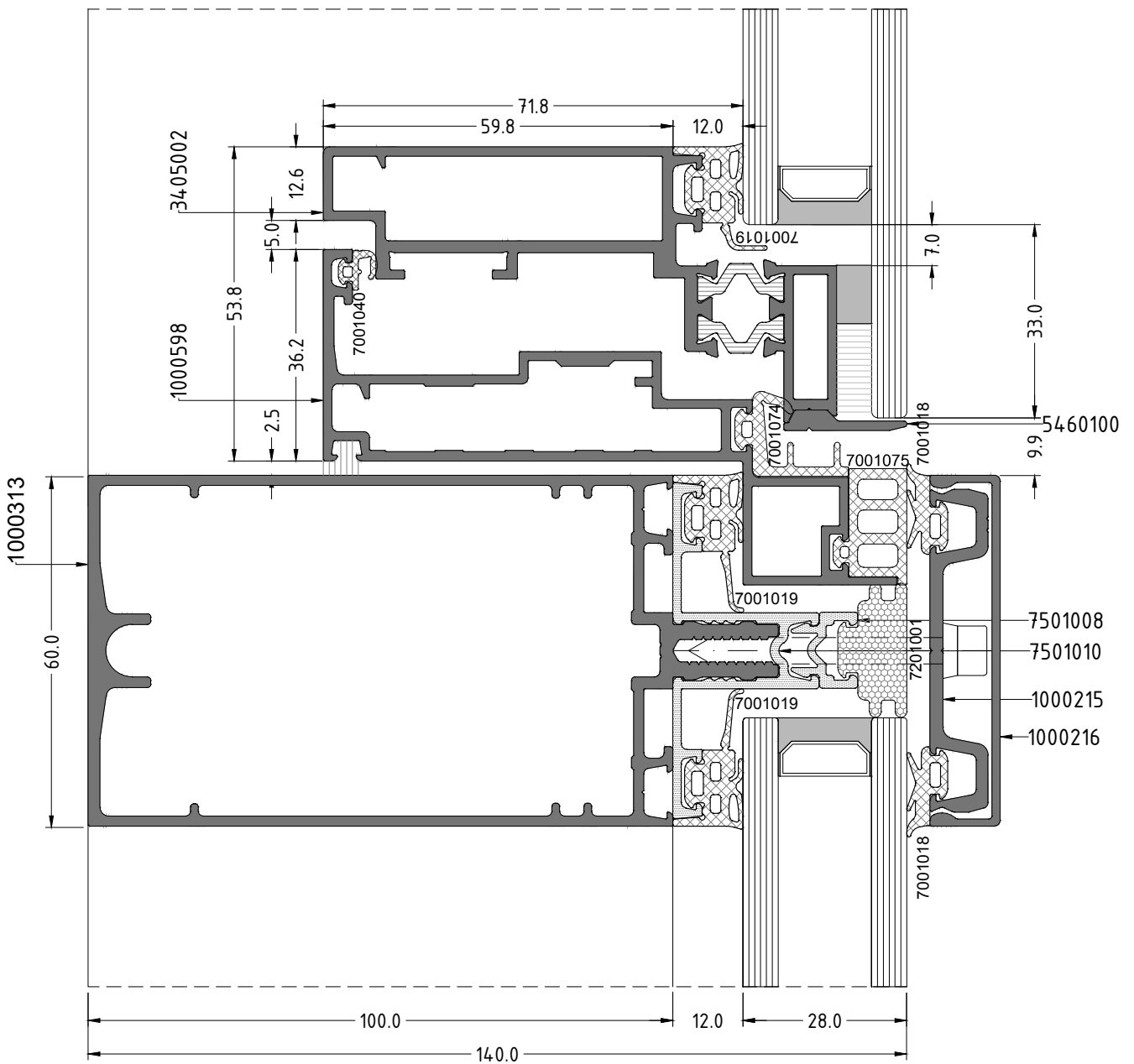
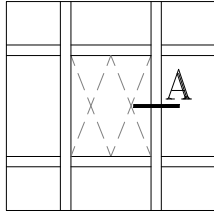

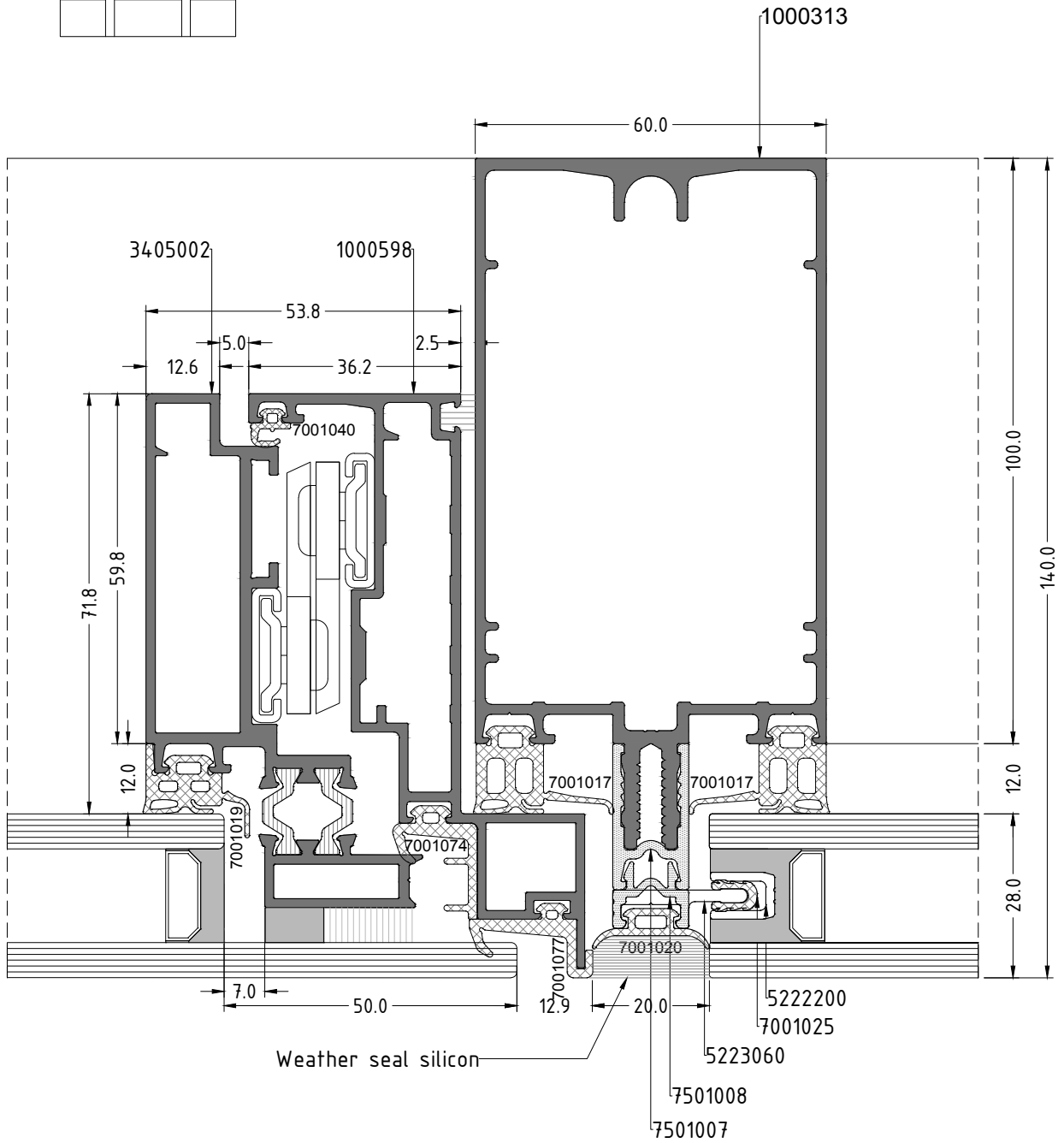
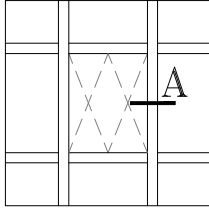

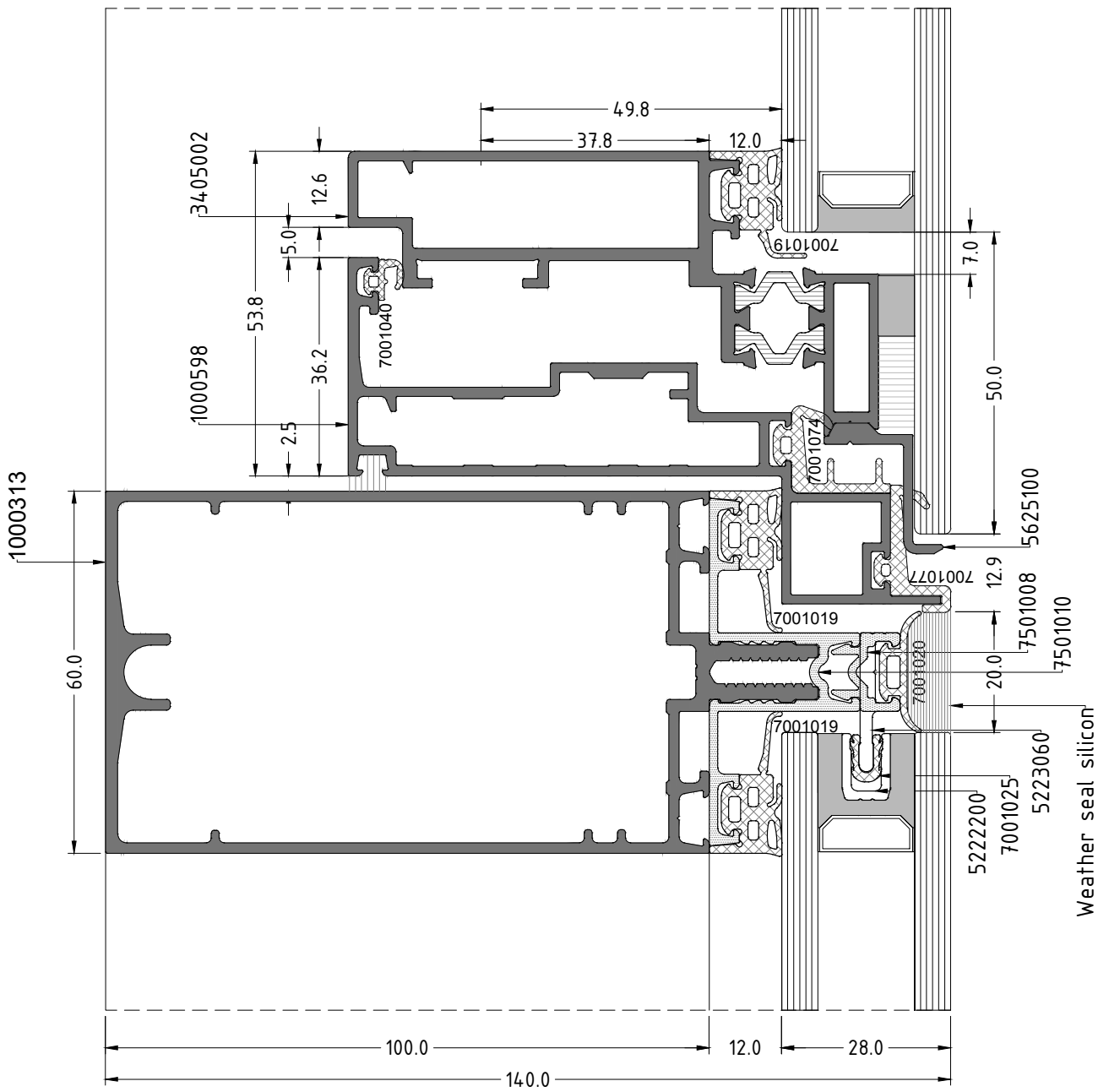
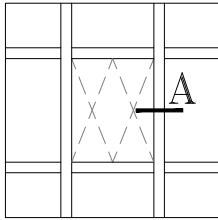

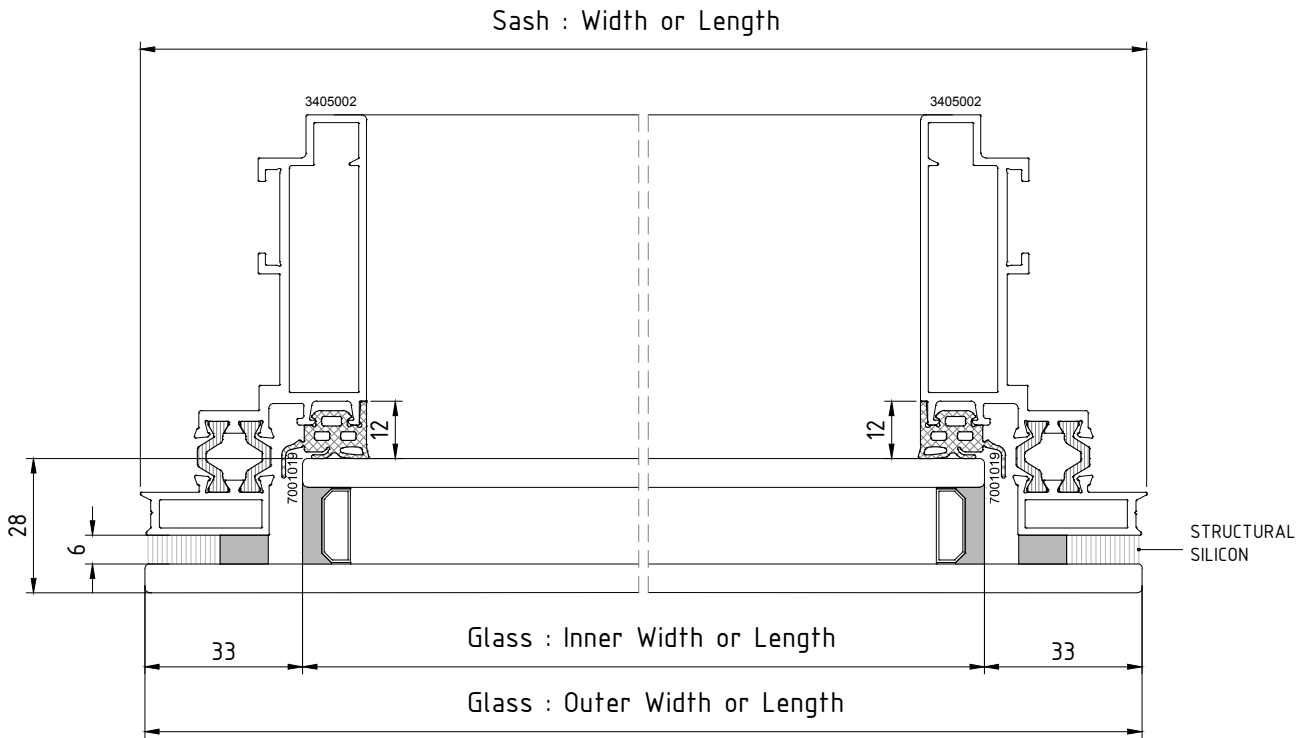

Cover cap curtain wall Parallel opening . Sash glazing detail

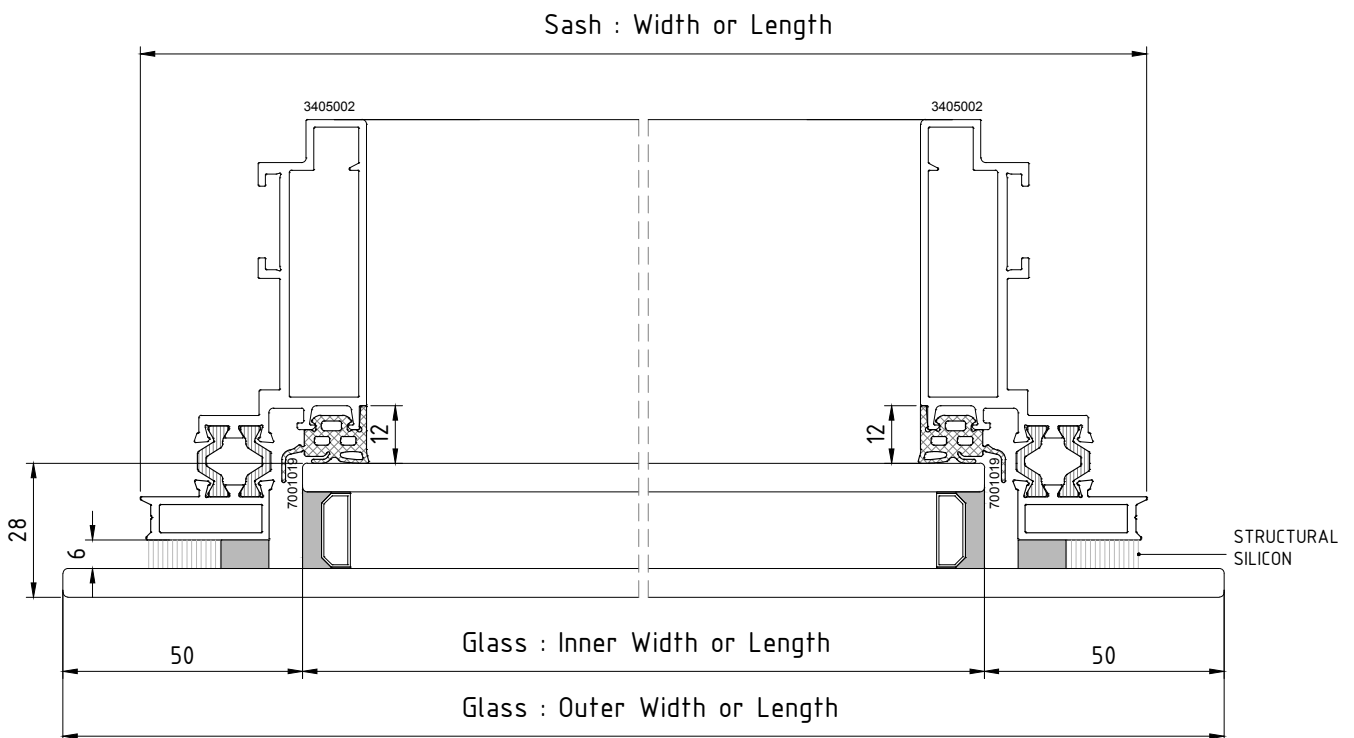

SG glazing curtain wall Parallel opening . Sash glazing detail

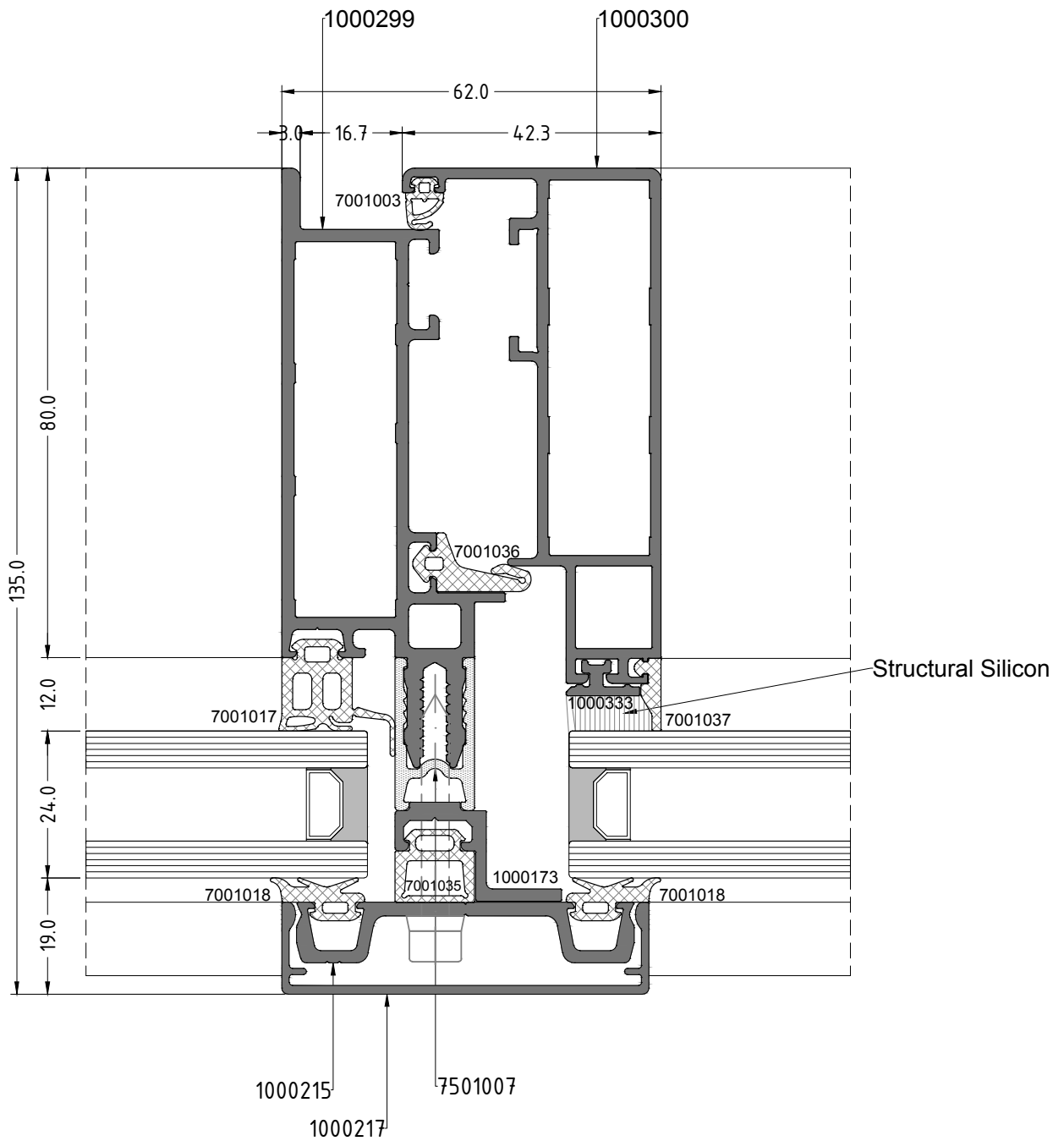
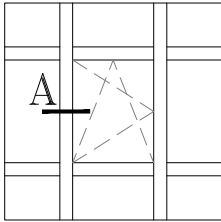

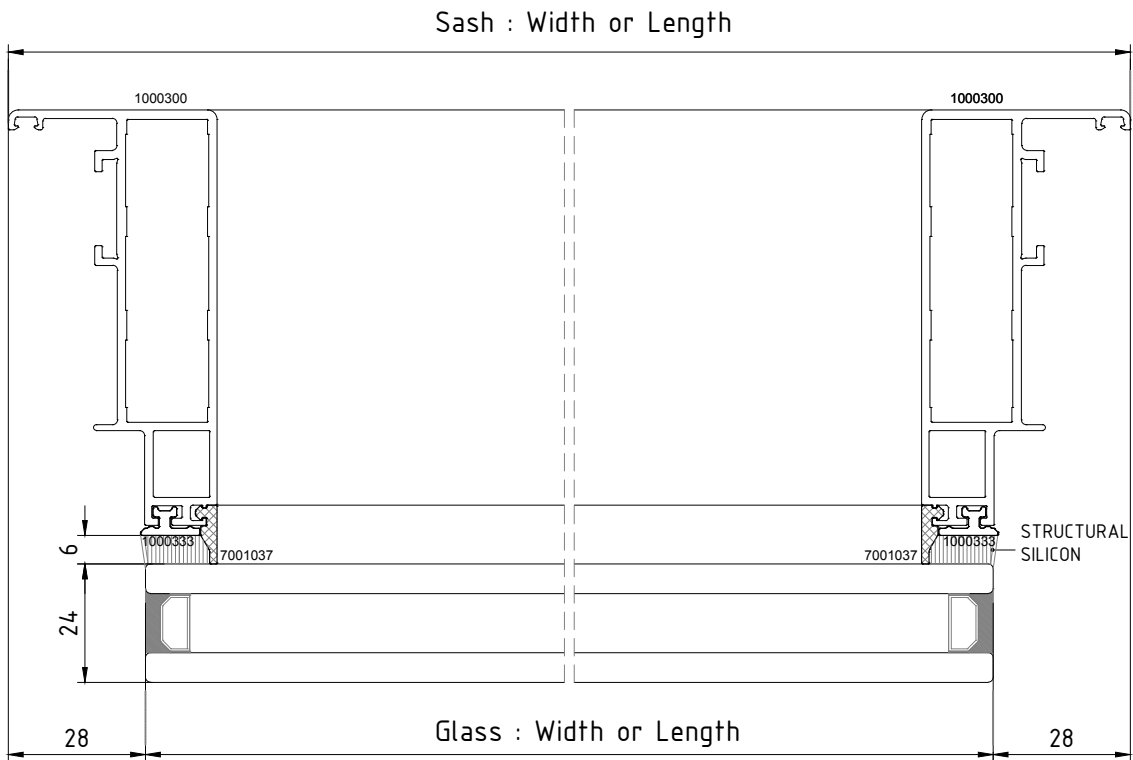

Hidden vent curtain wall opening . Sash glazing detail

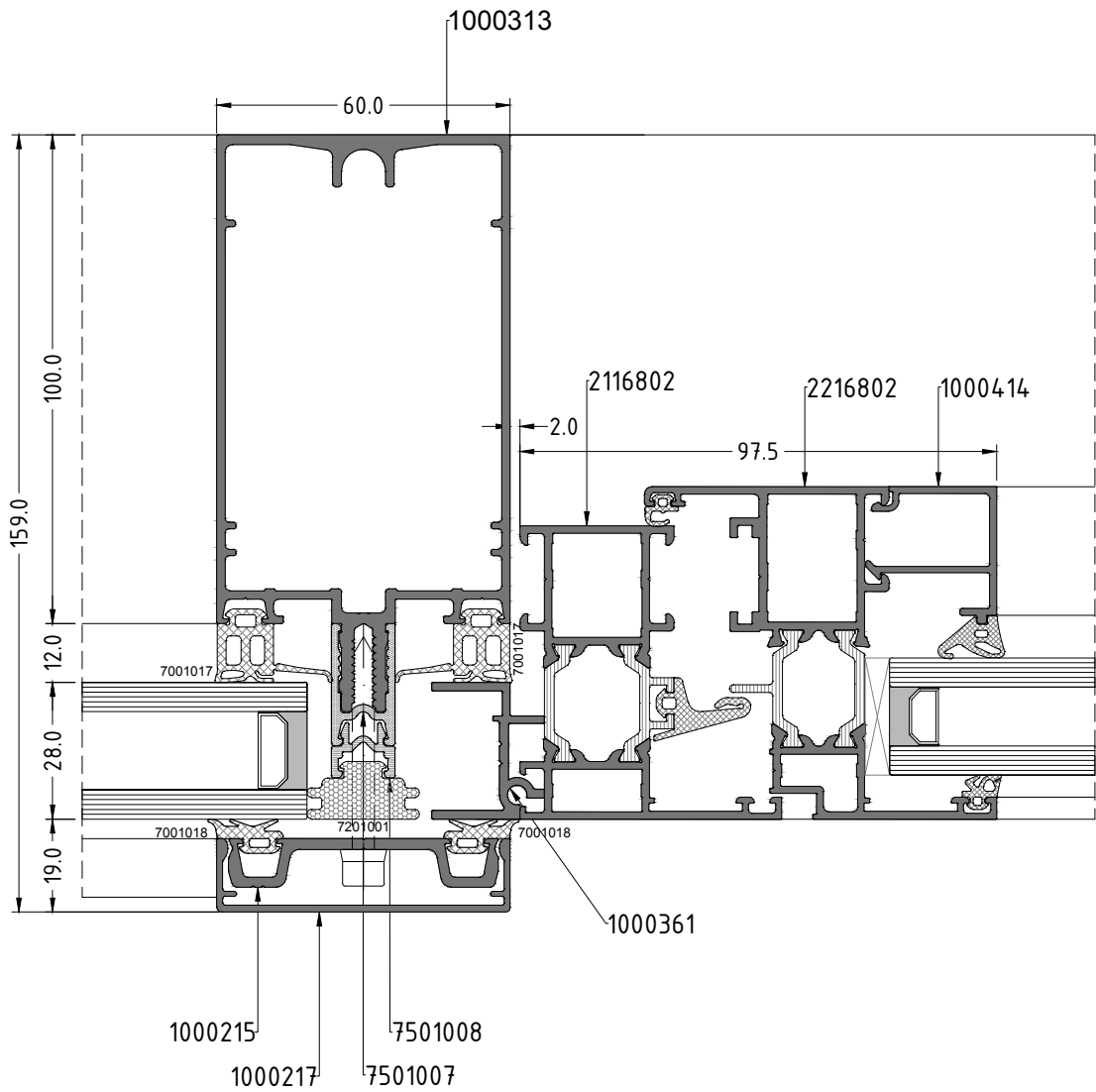
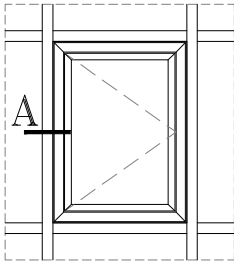

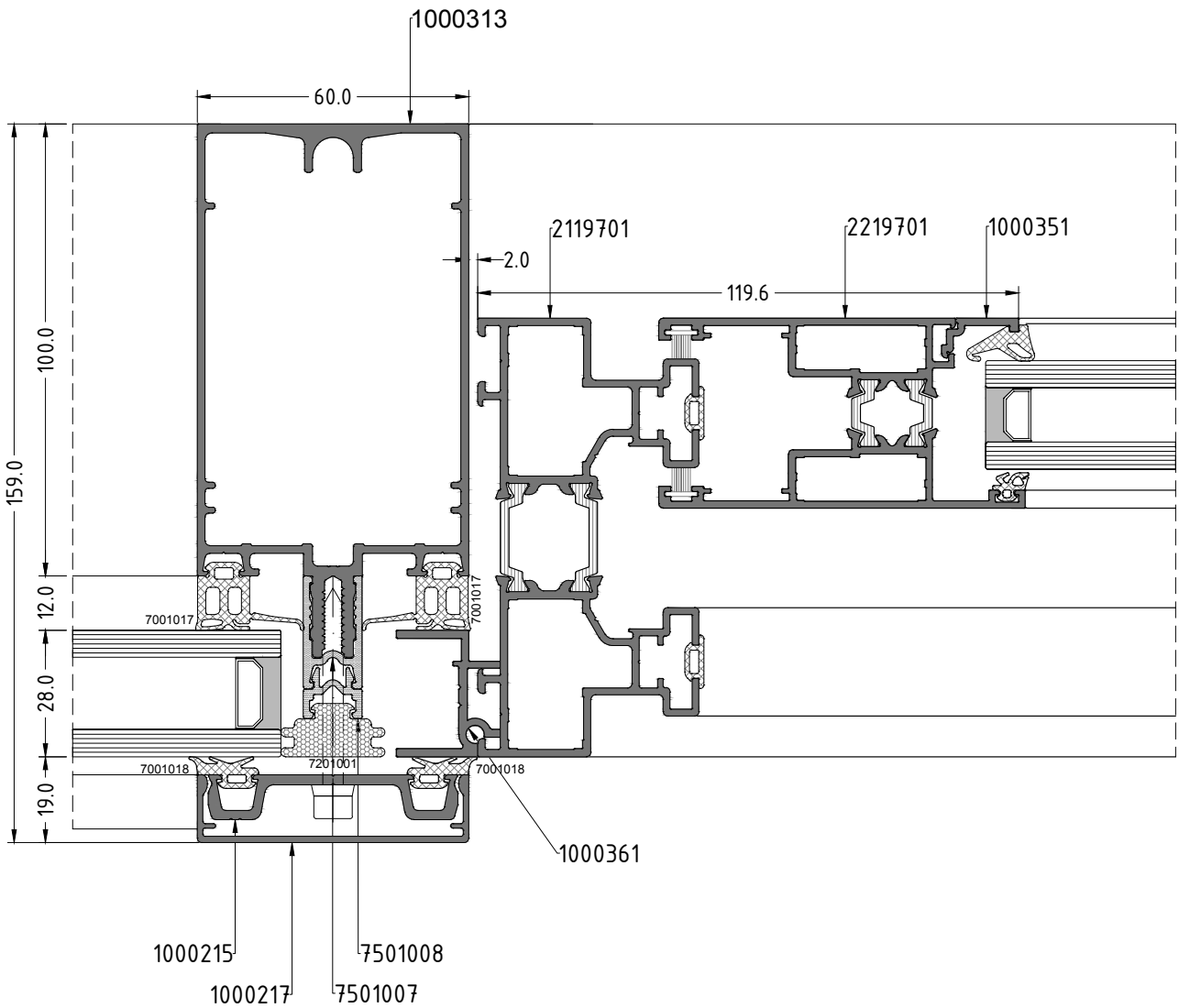
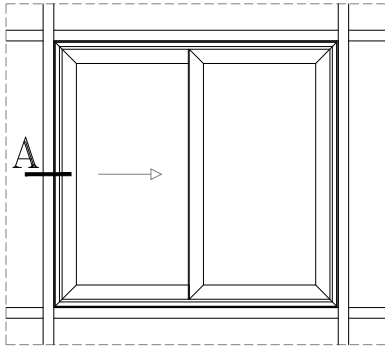

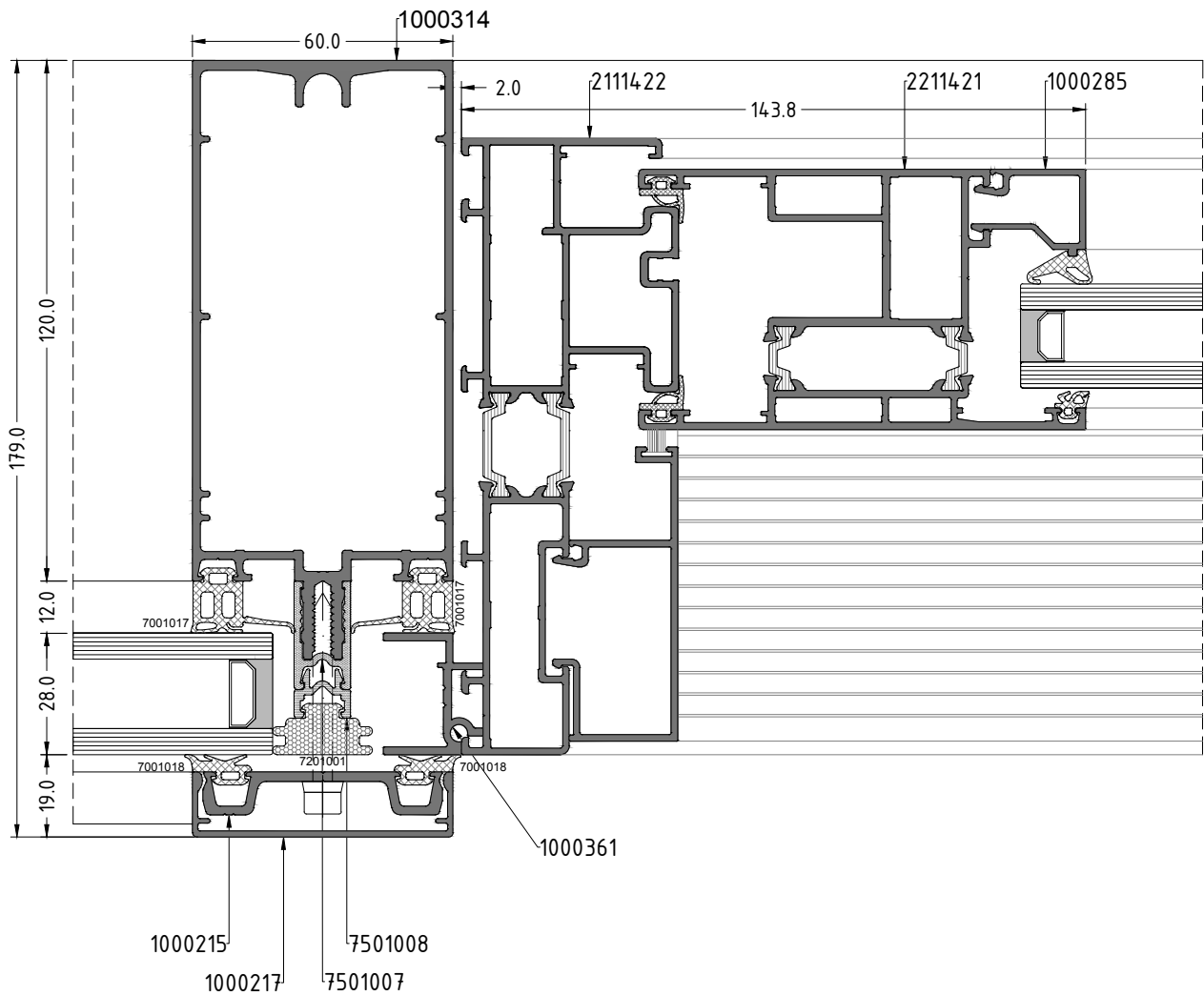
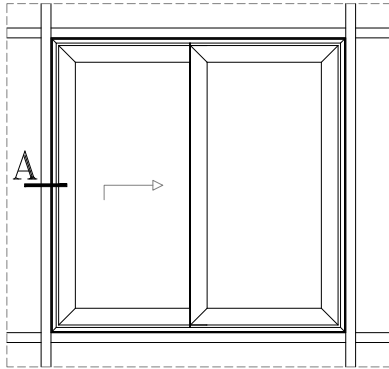

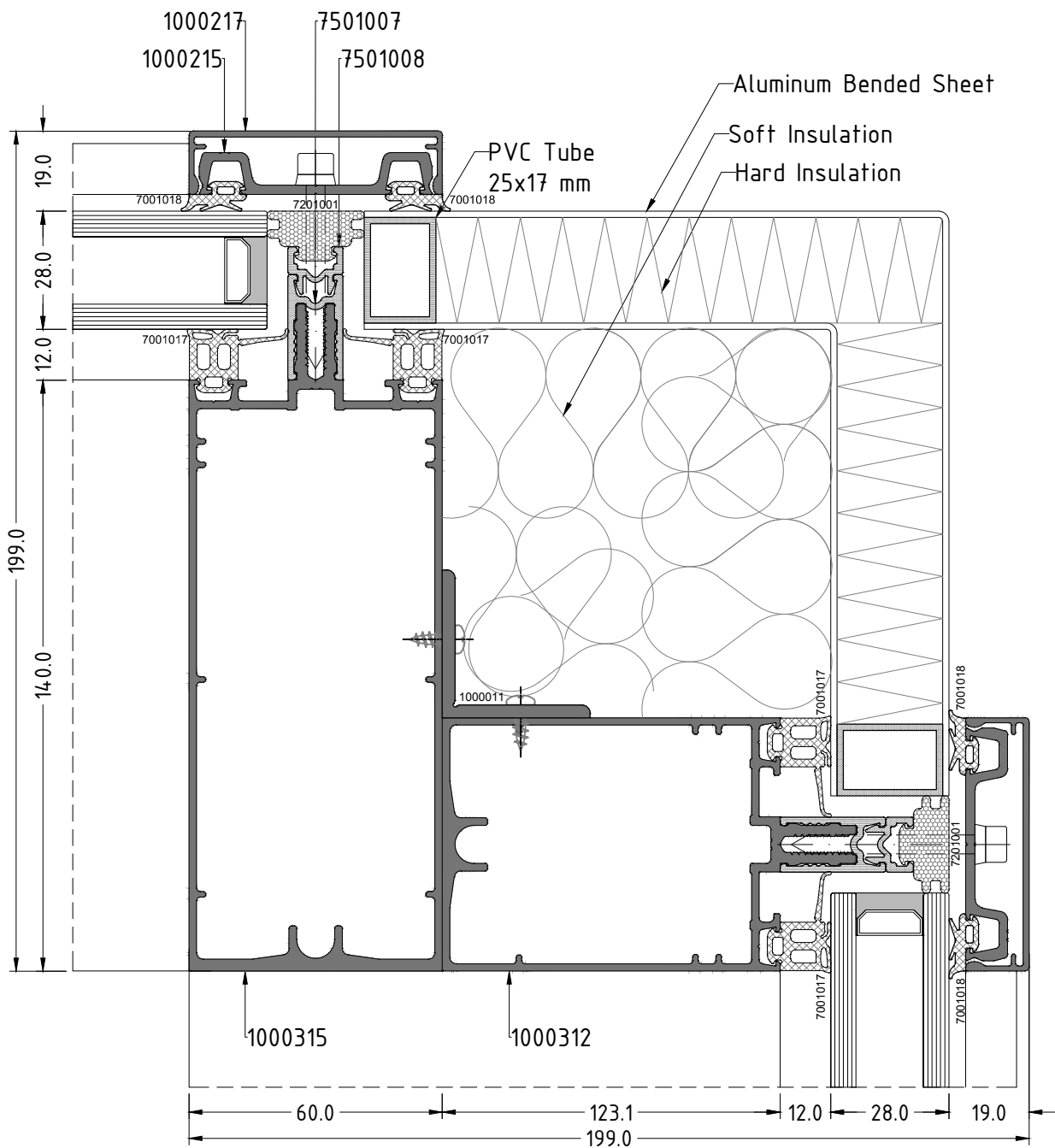
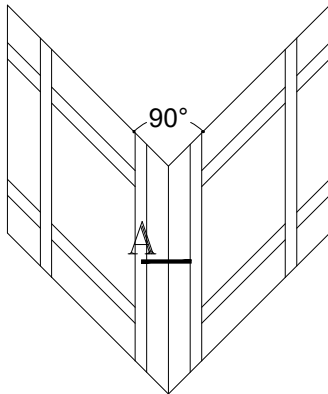

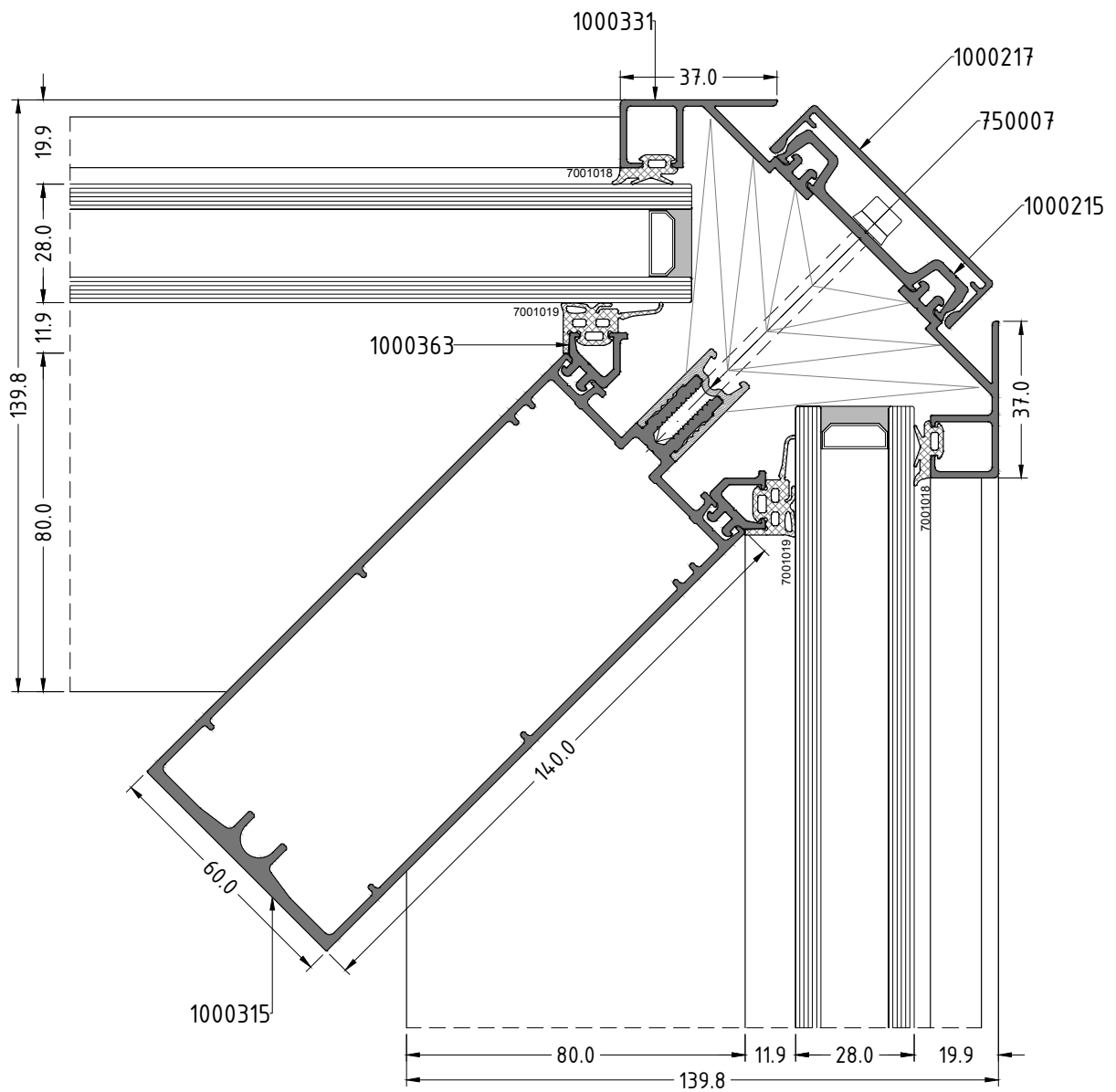
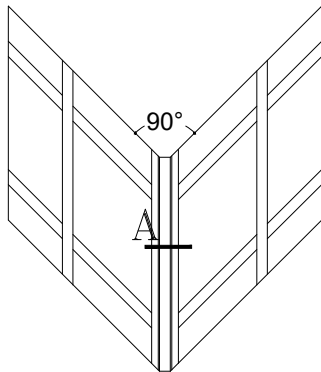

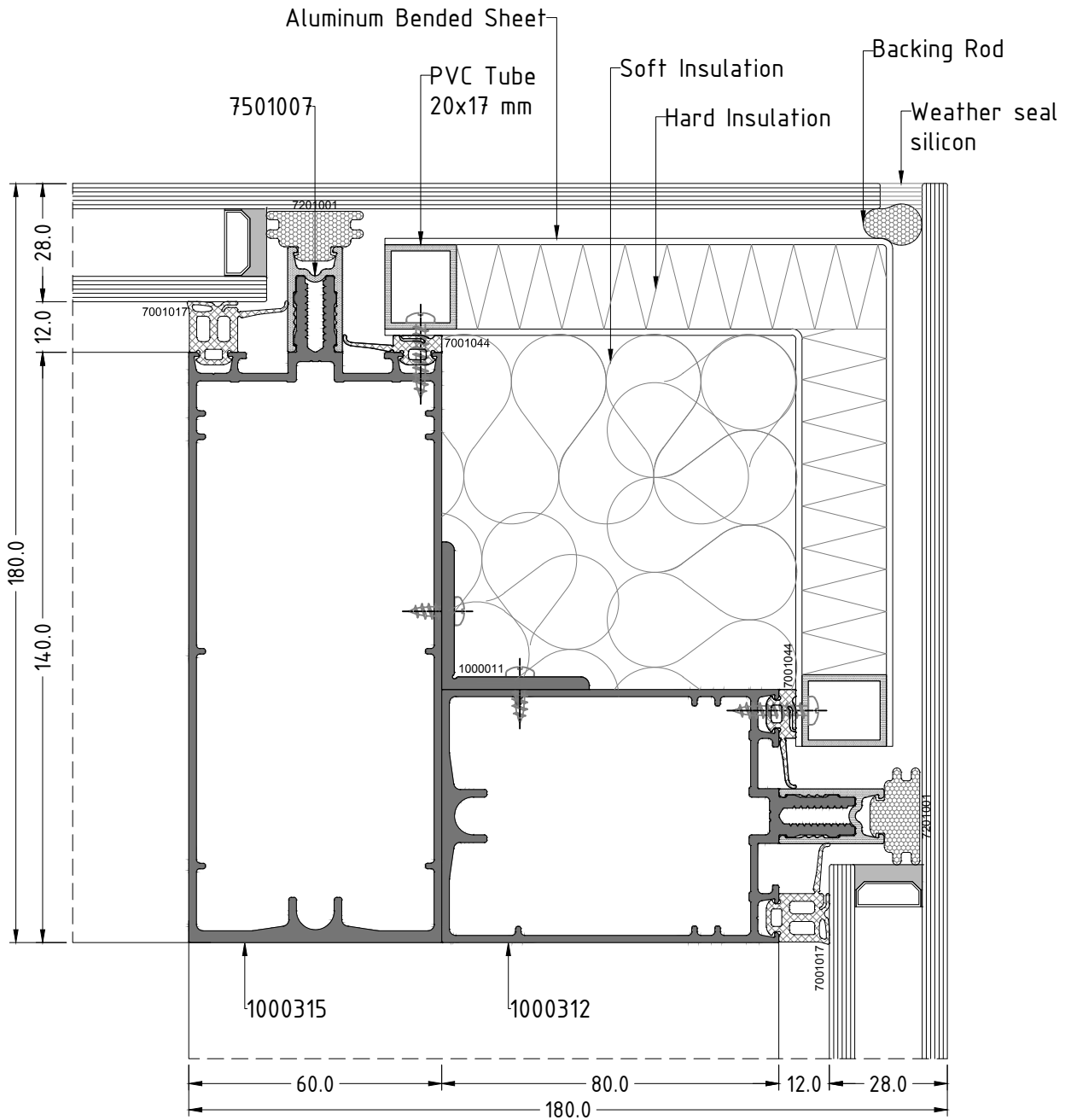
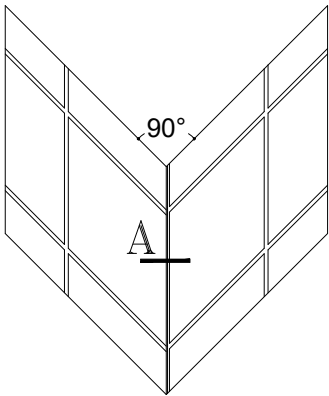

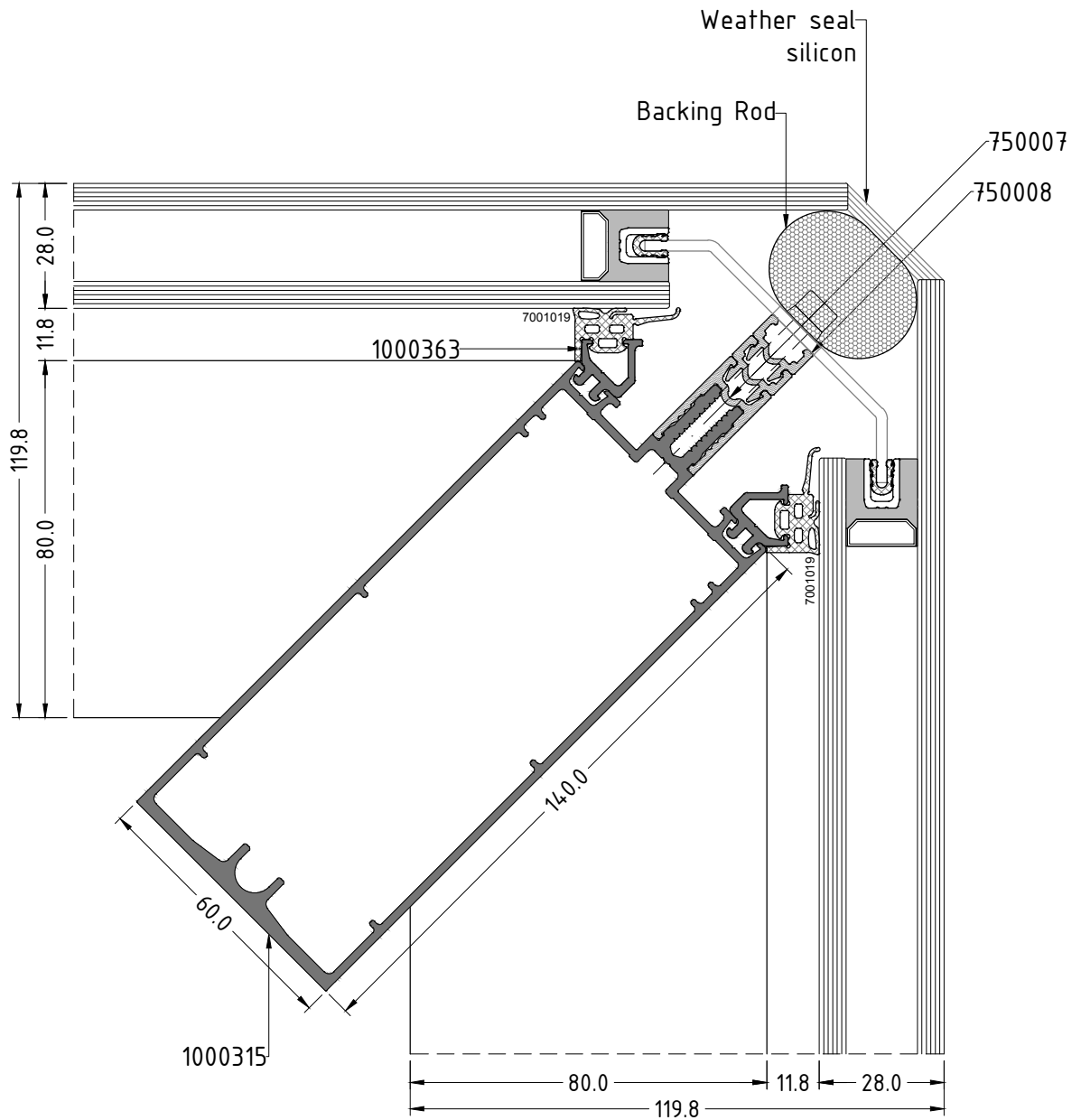
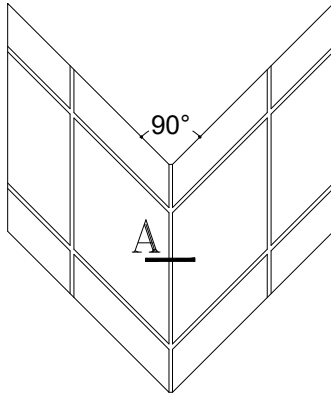

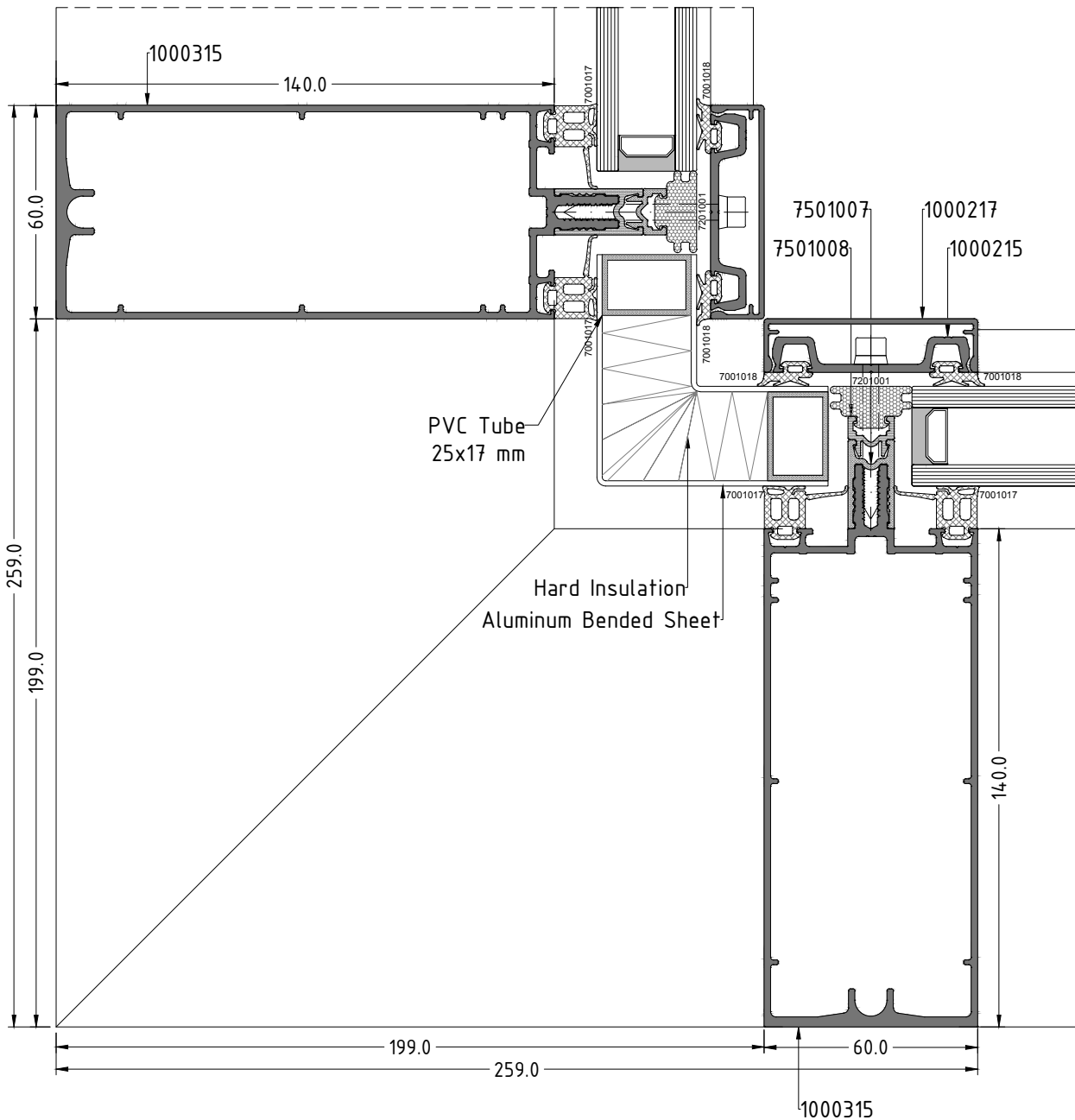
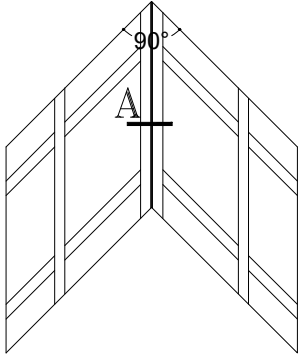

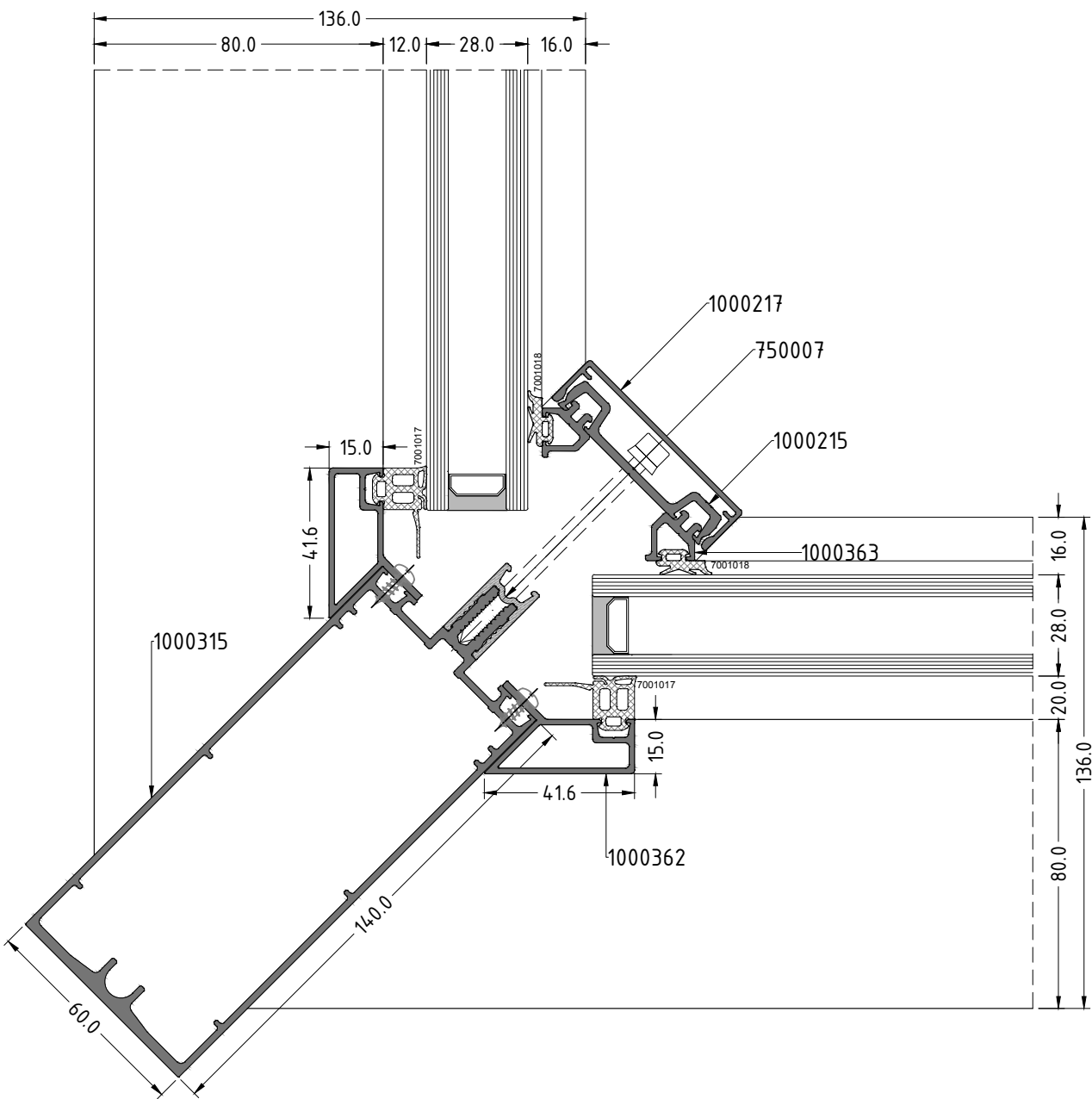
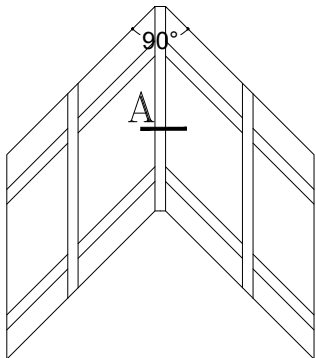

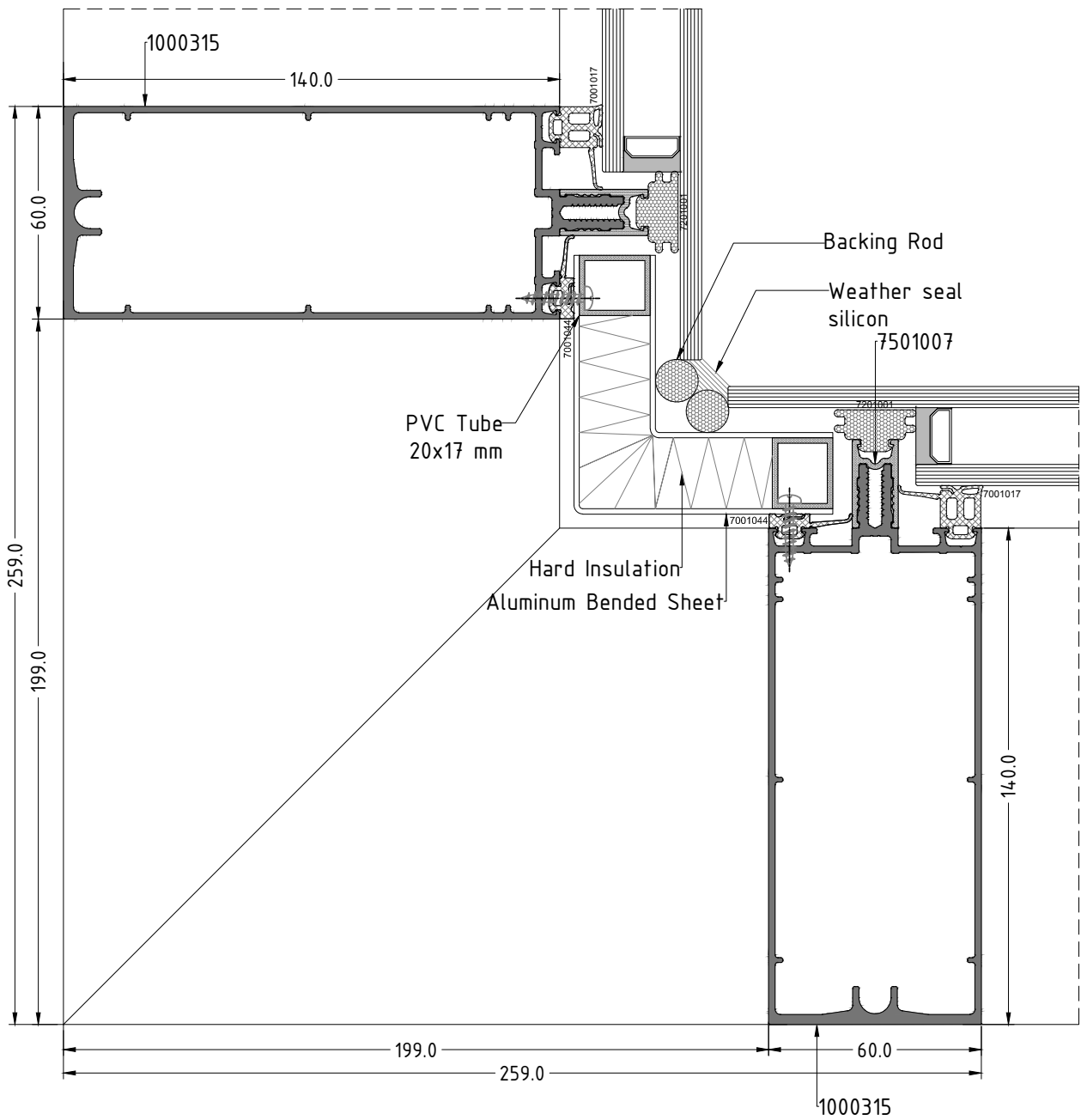
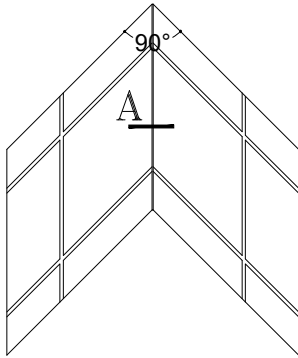

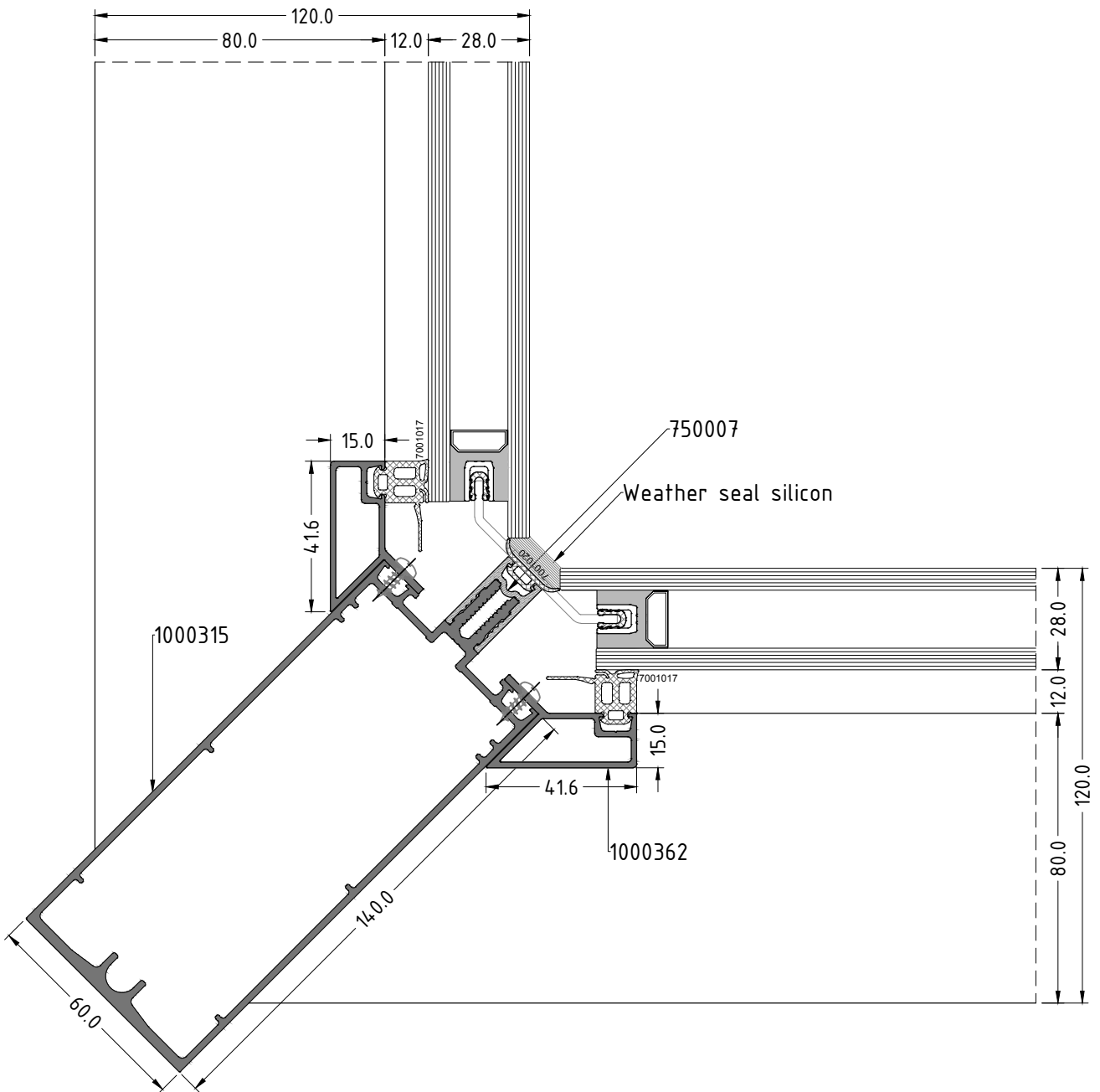
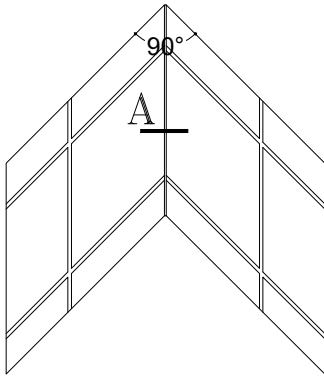

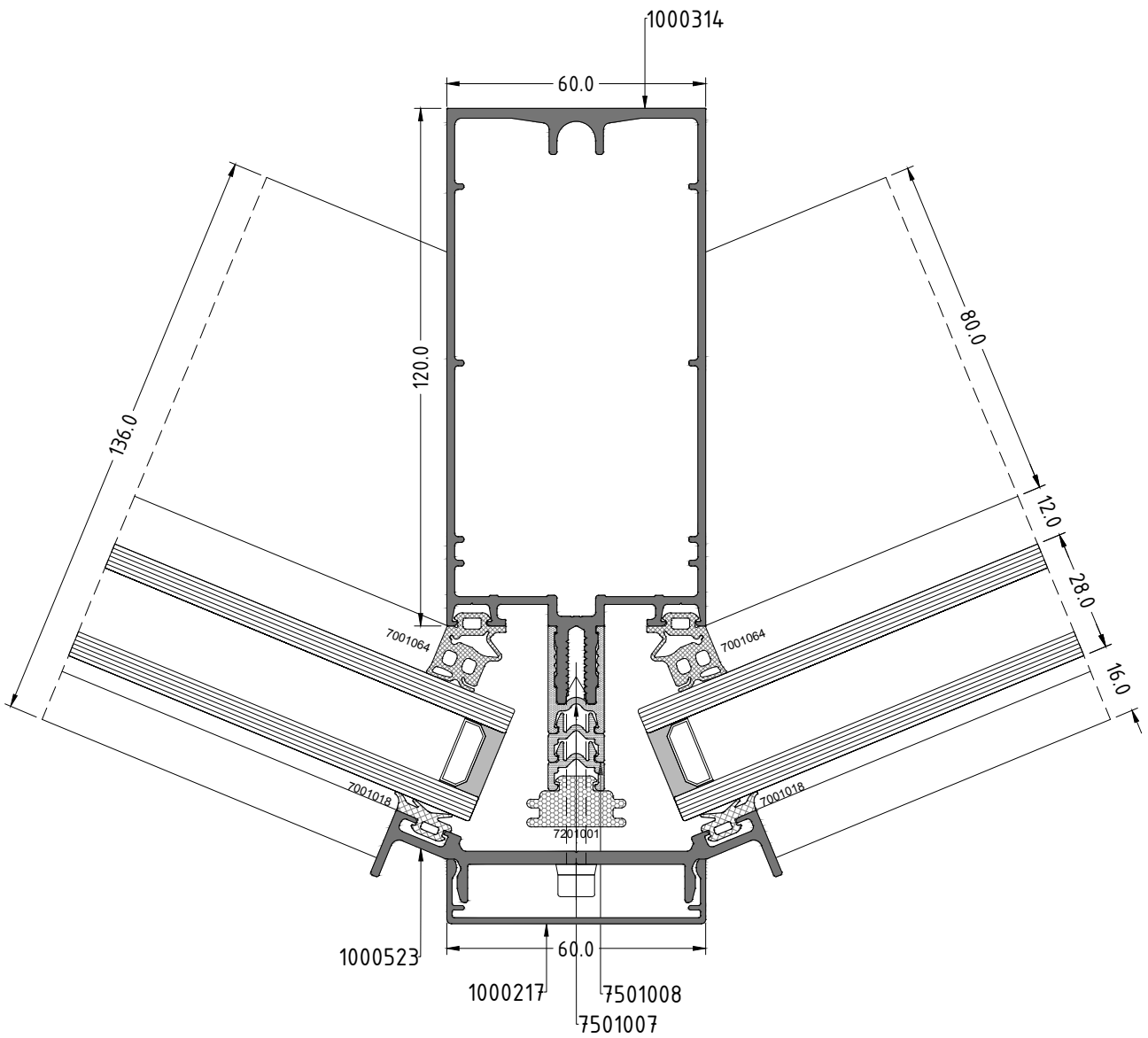
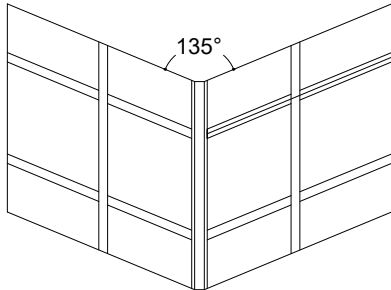

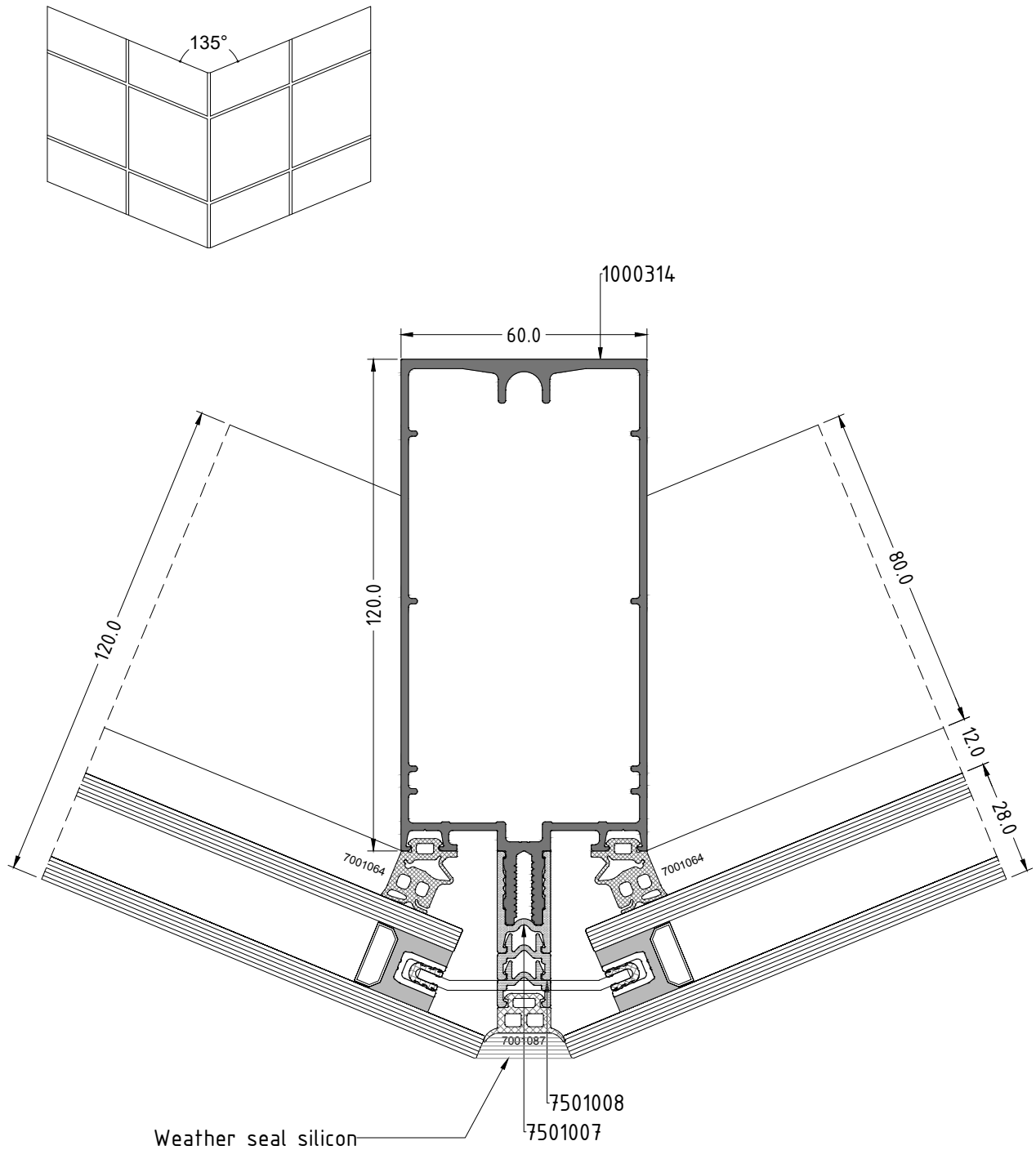

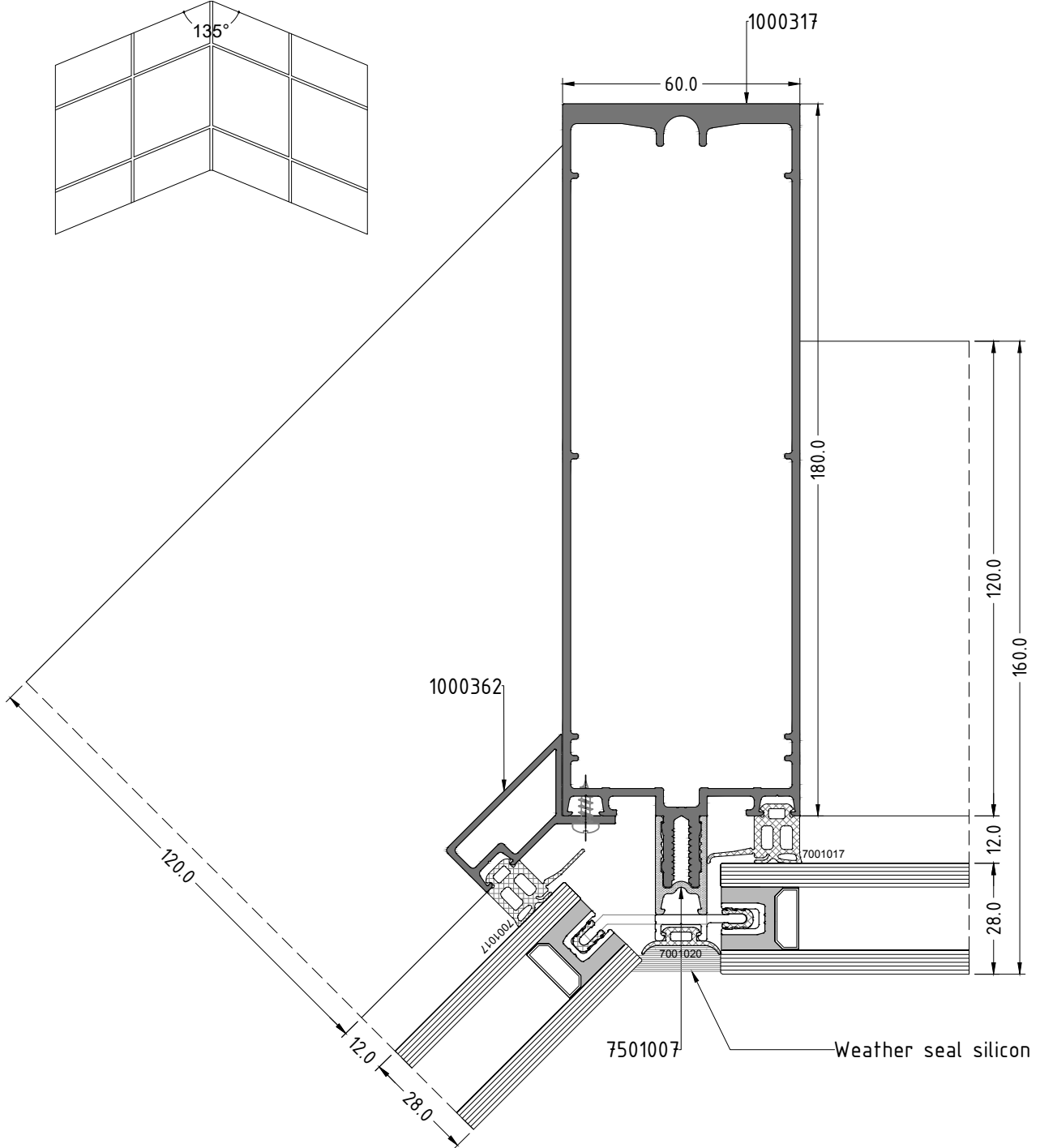

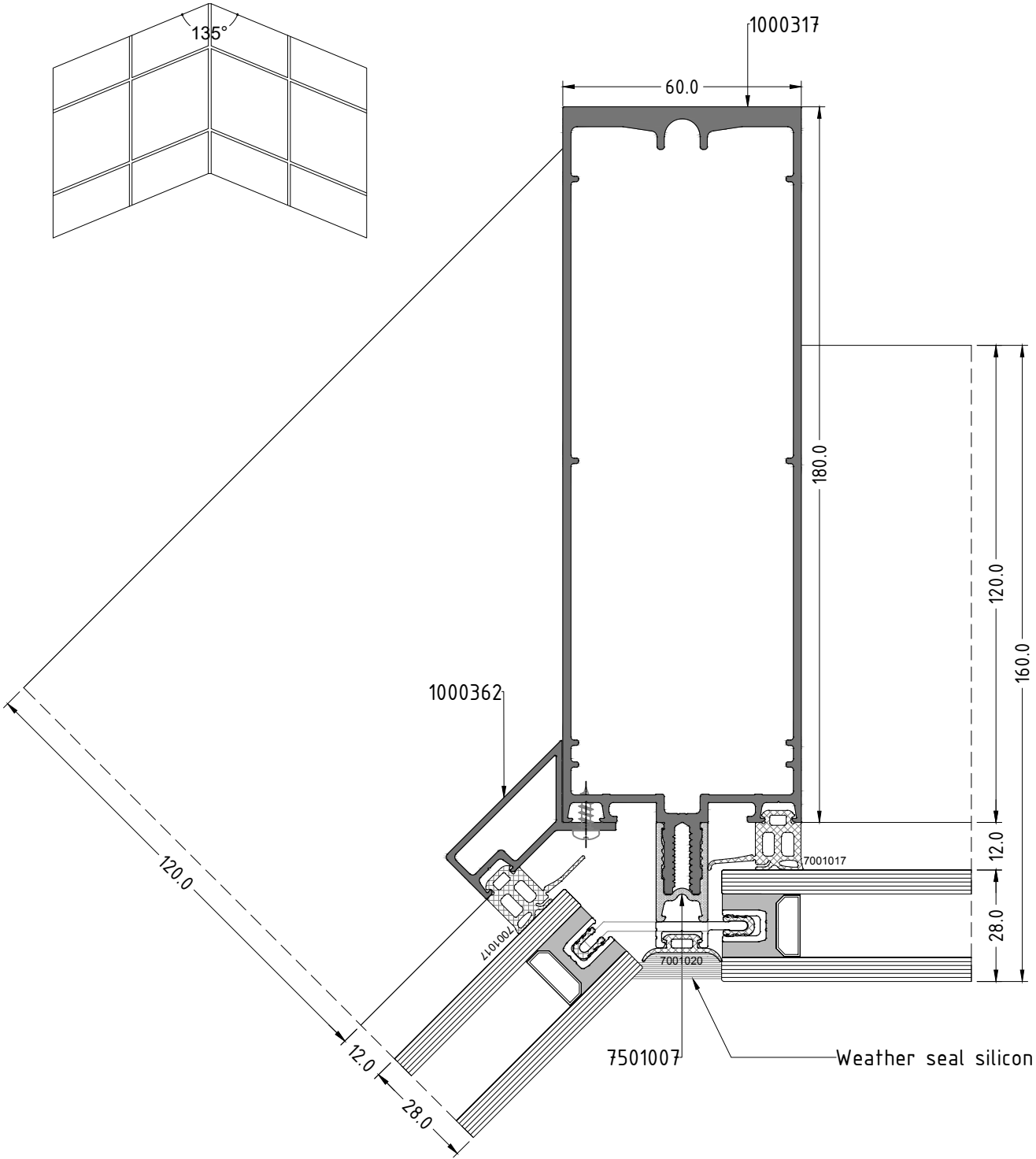

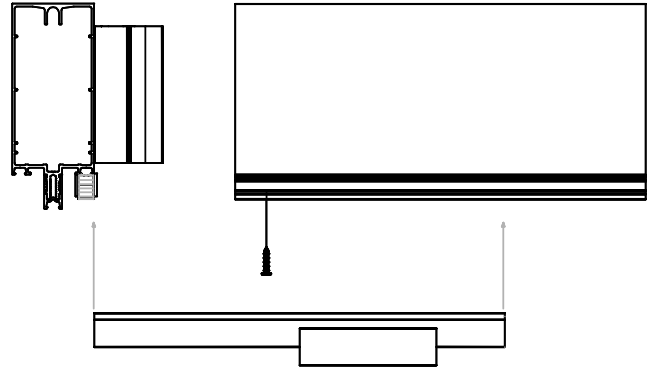

Transom Gasket Item No. 7801004 In sloped-roof structures, seal the areas between the transom gasket and the PVC insulator with Sealing Compound

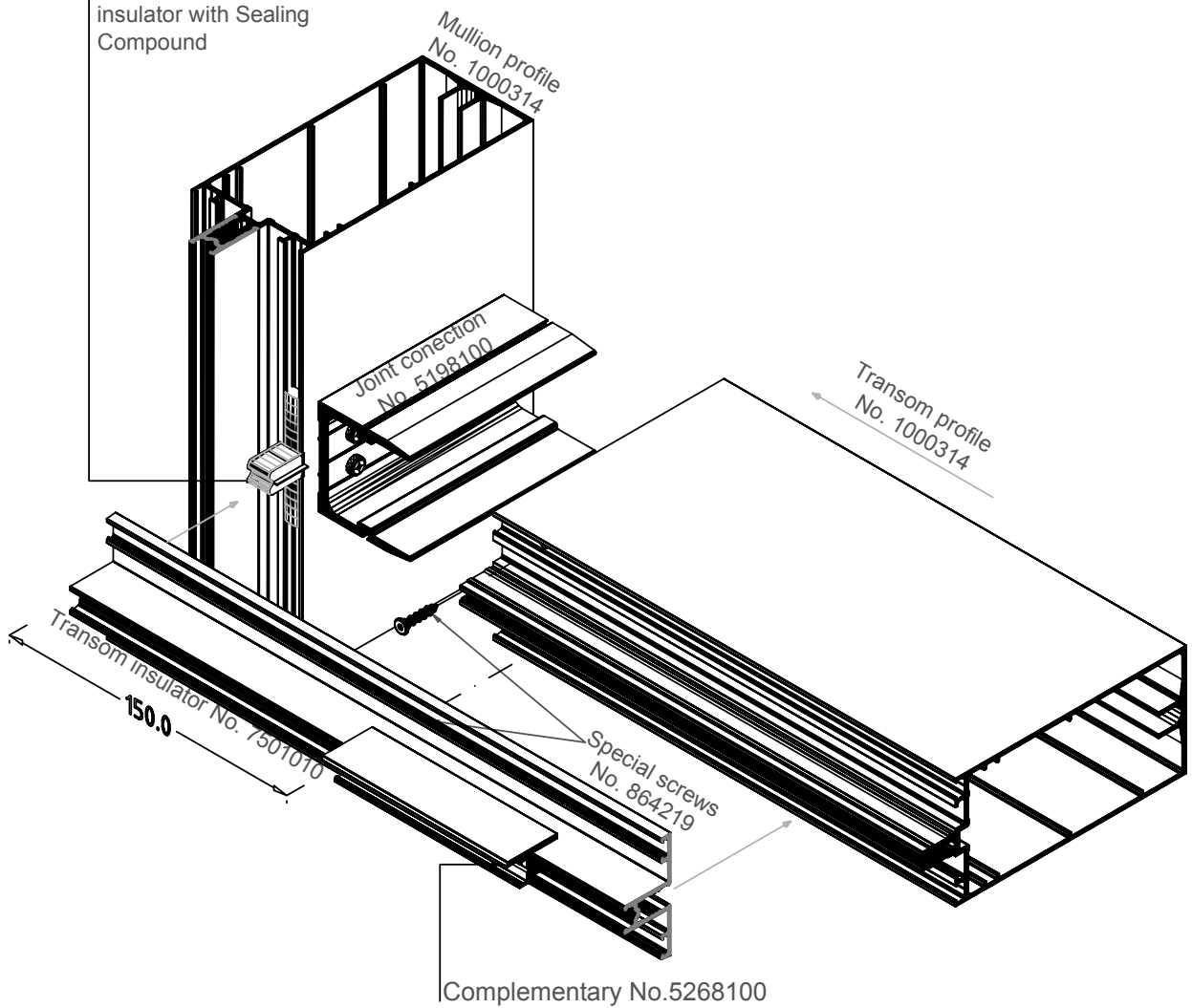

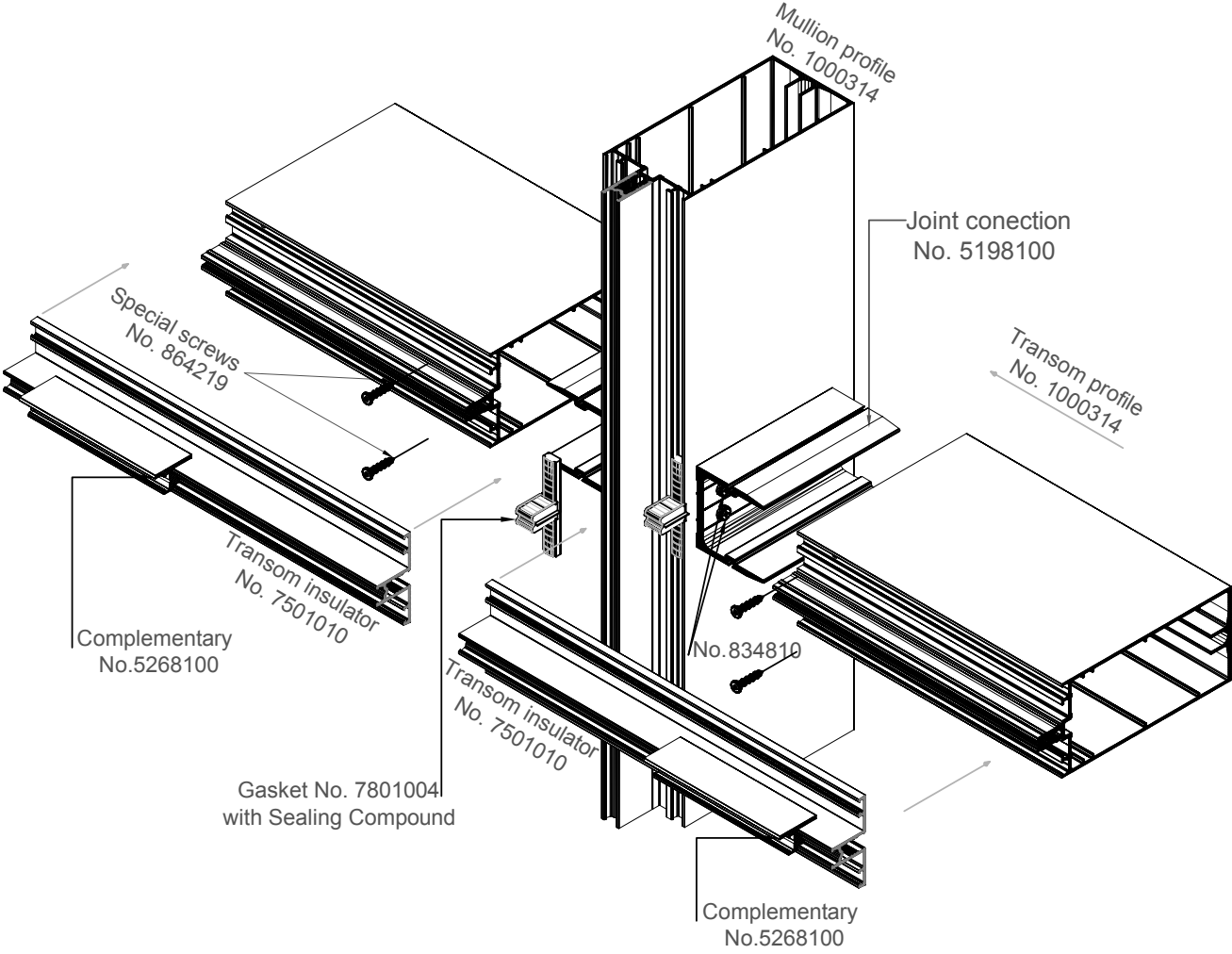
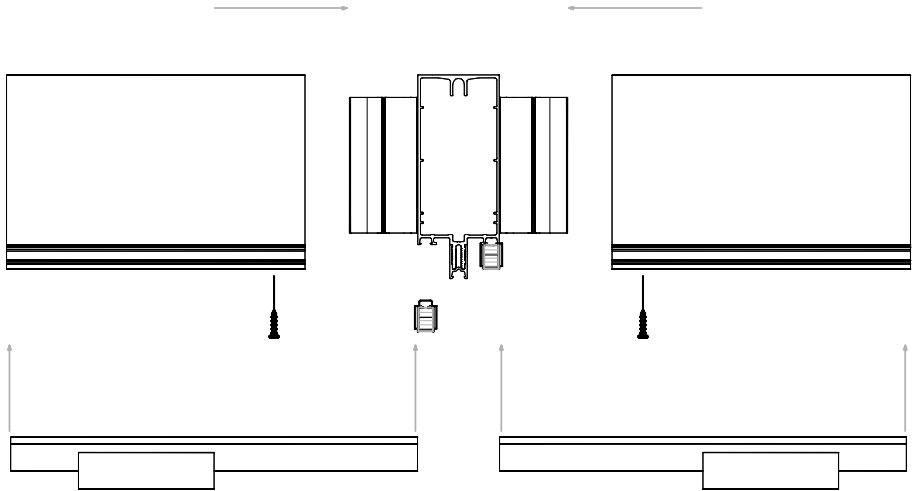

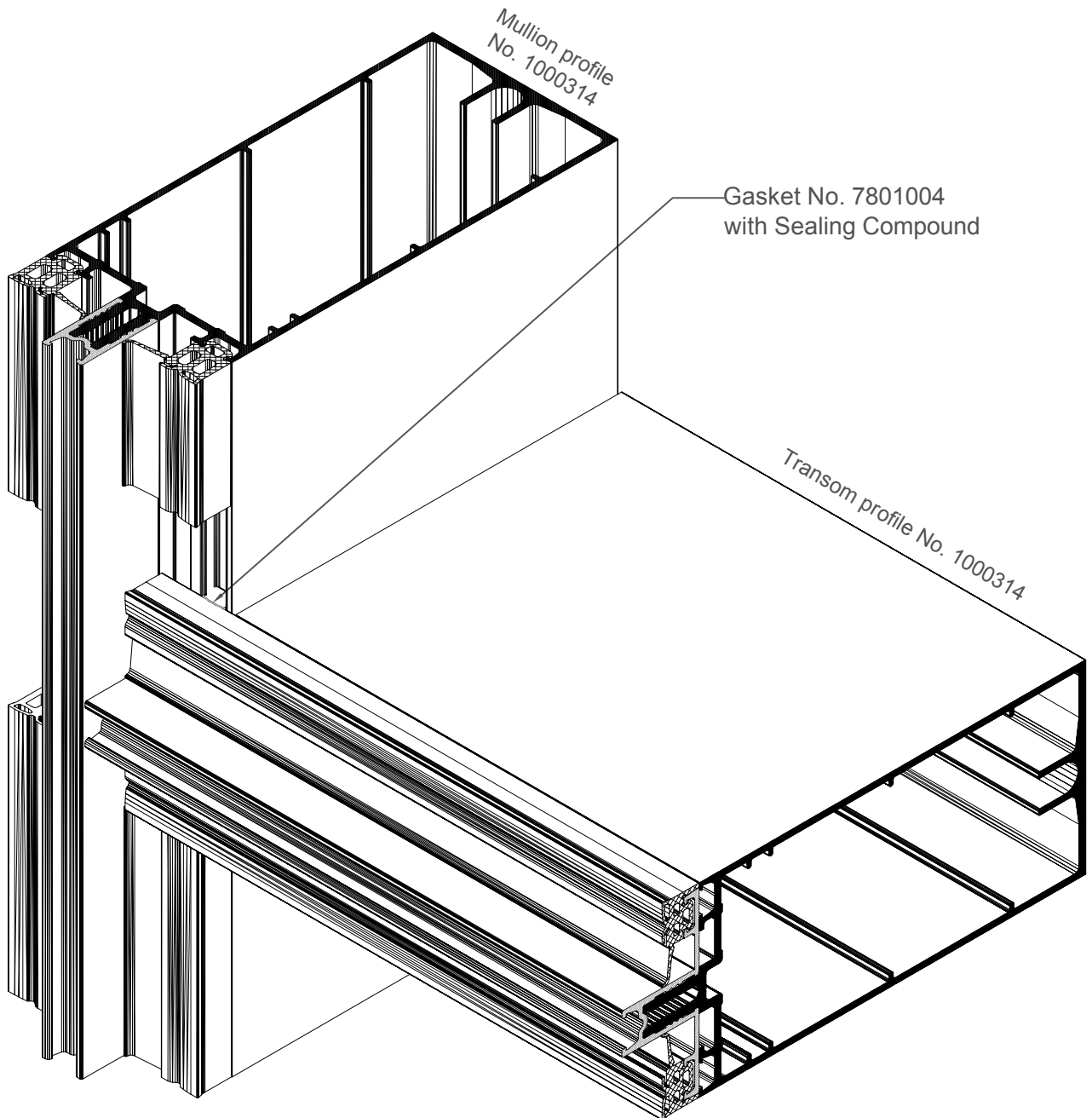

Transom Gasket Item No. 7801004 In sloped-roof structures, seal the areas between the transom gasket and the PVC insulator with Sealing Compound

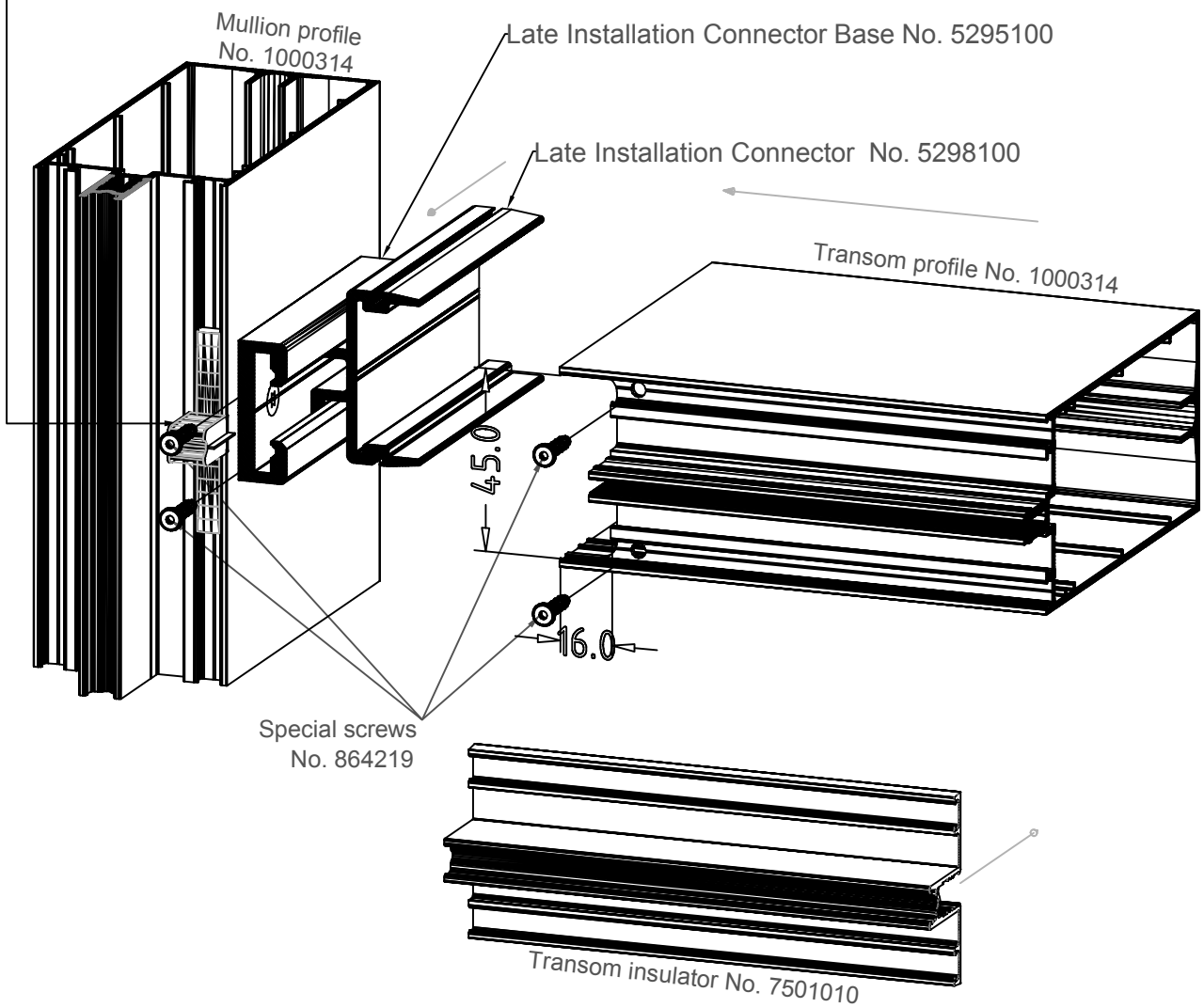

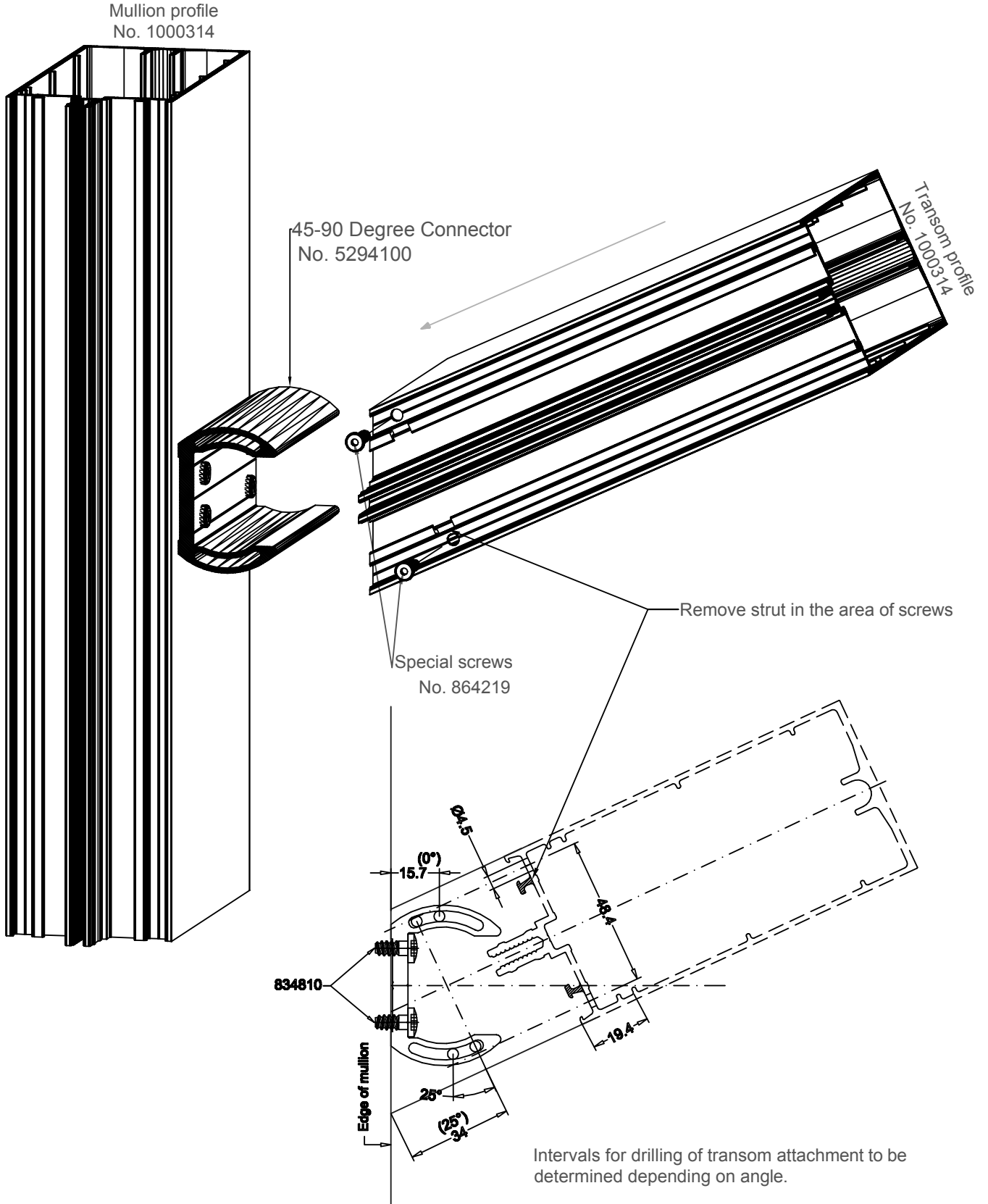

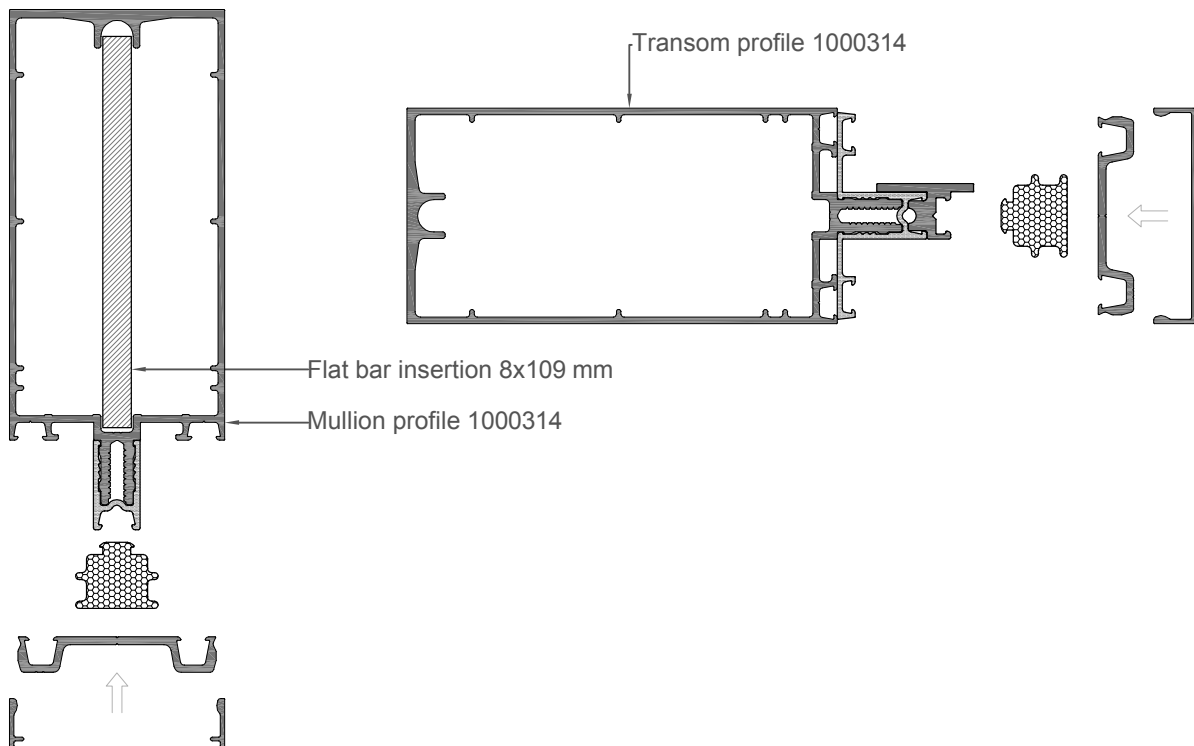
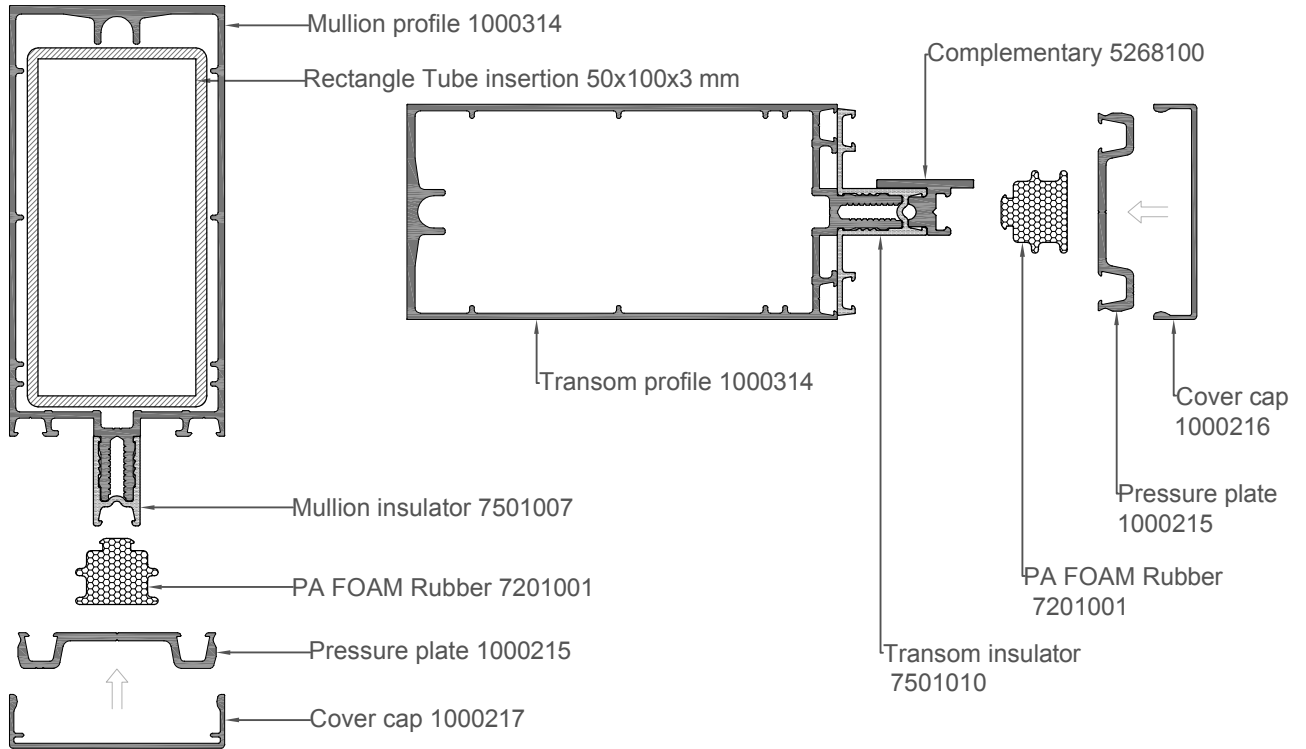

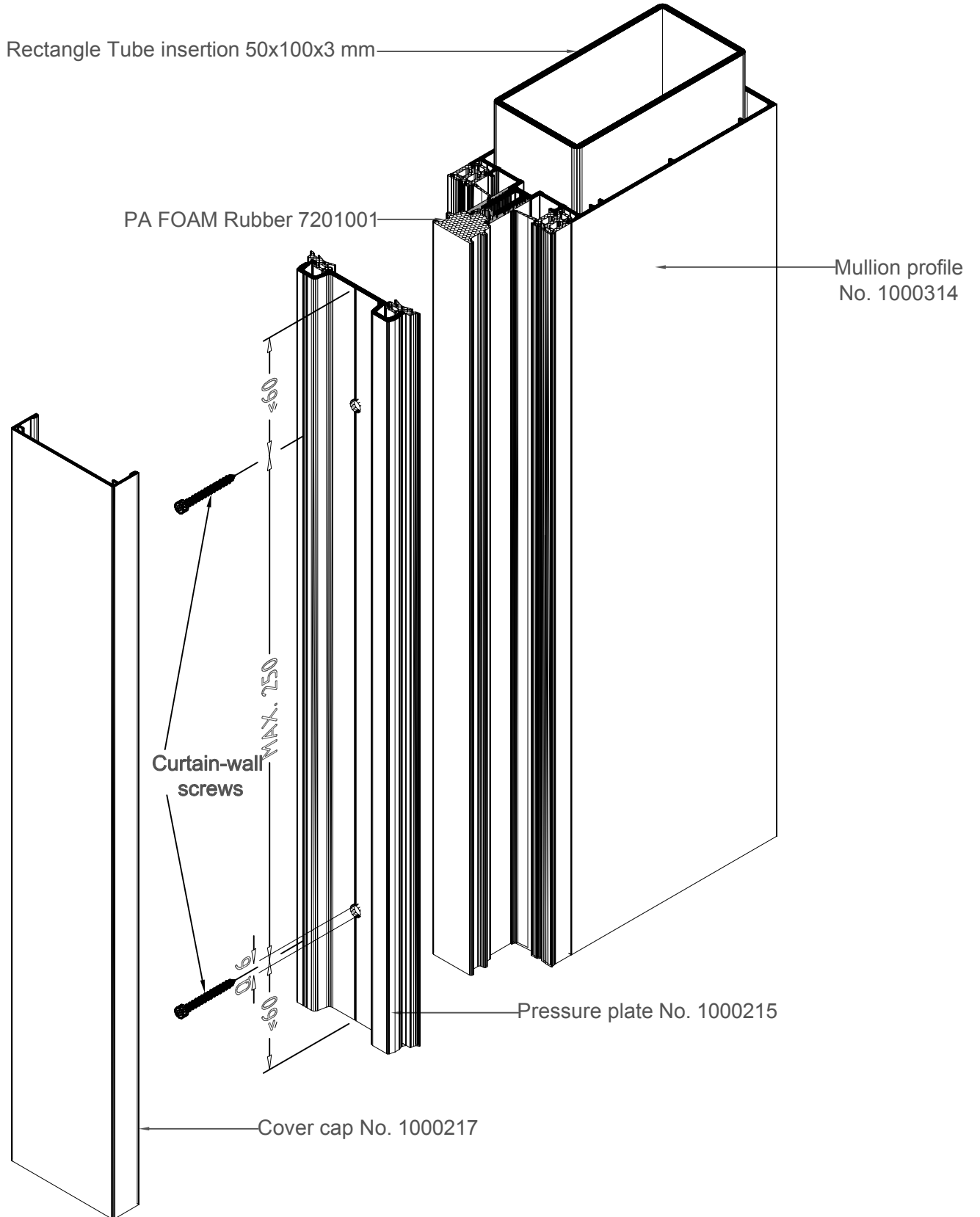

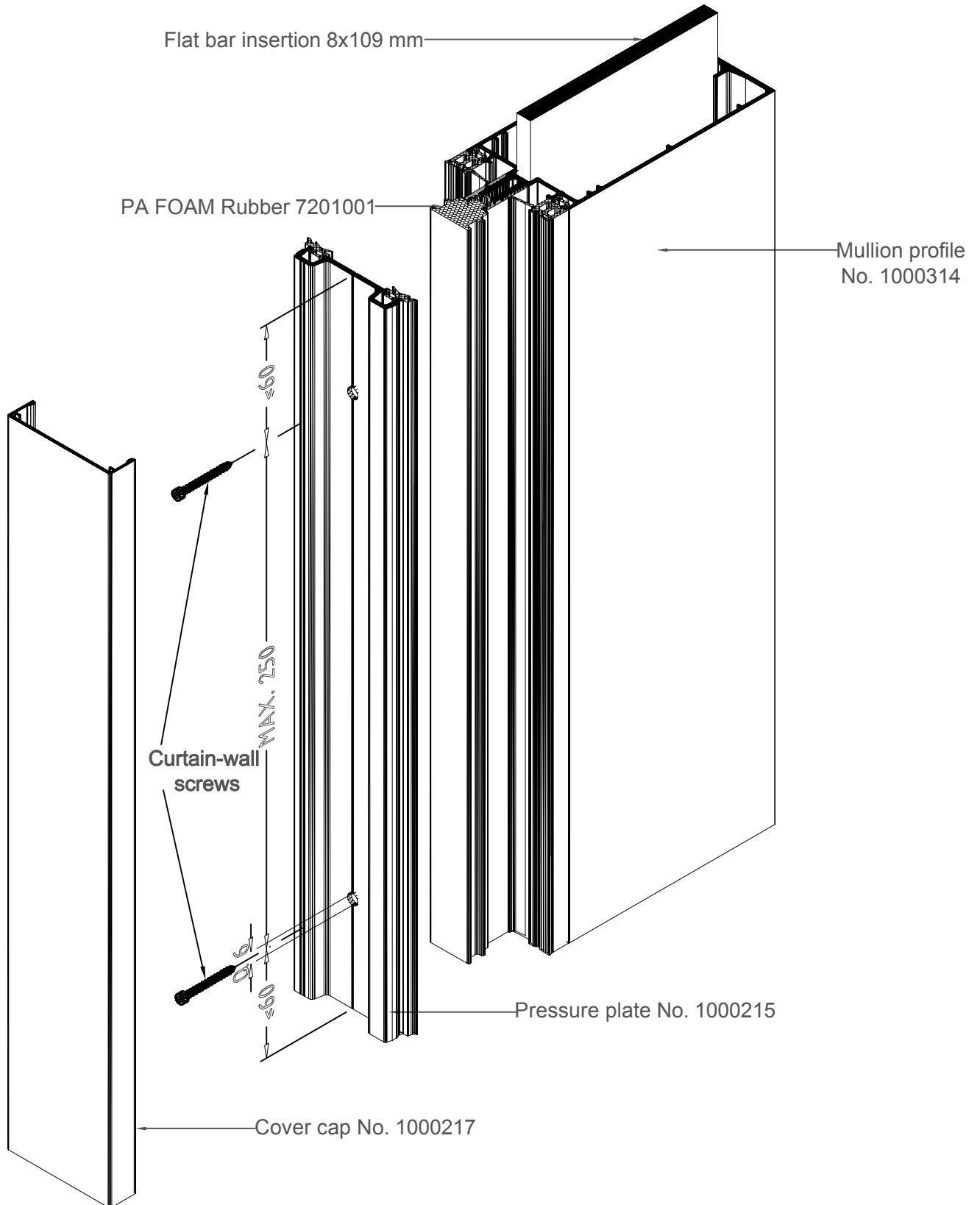

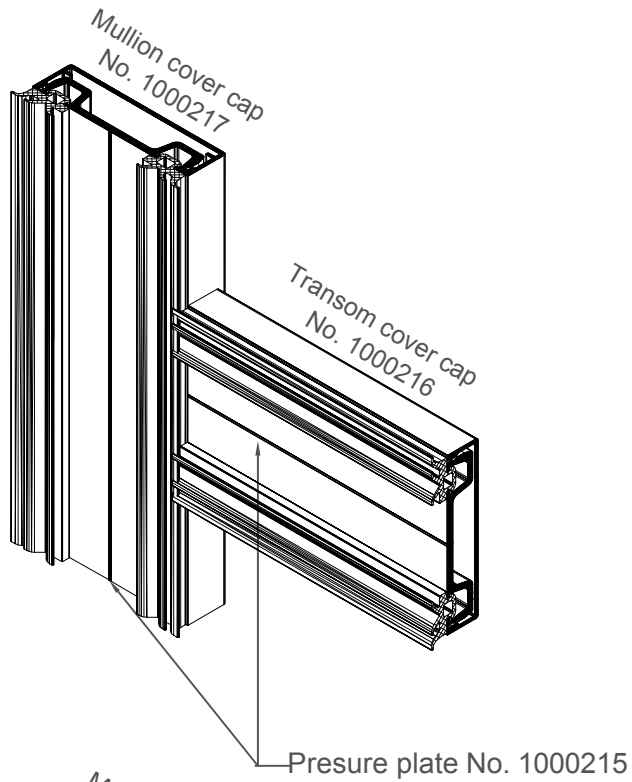

Mullion-transom joint
without pressure plate gasket

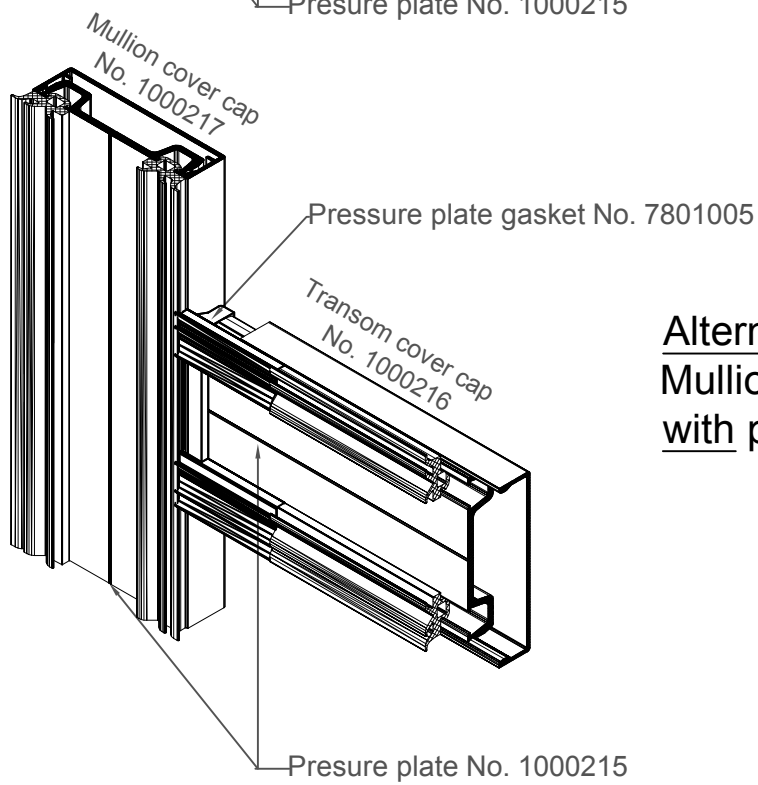

Alternative:
Mullion-transom joint
with pressure plate gasket

