

# WGA 73

WINTERGARDEN SYSTEM

# WGA 73

## WINTERGARDEN SYSTEM



ACCURACY



HARMONY



BALANCE

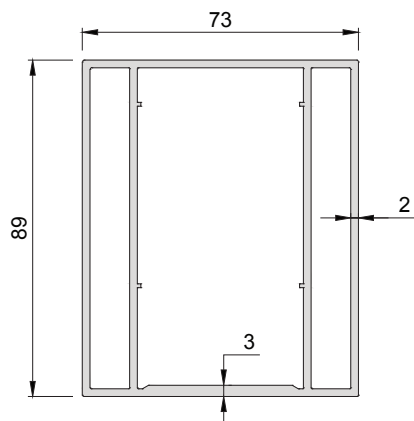

580-1201 ( 2,743 kg/mt )  
SRA150 M03 CARRIER SEWING PROFILE

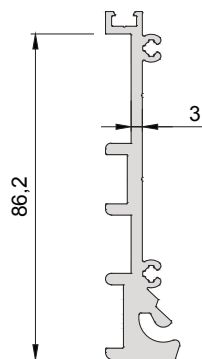

580-1204 ( 1,450 kg/mt )  
SRA150M06 WALL FINISHING PROFILE

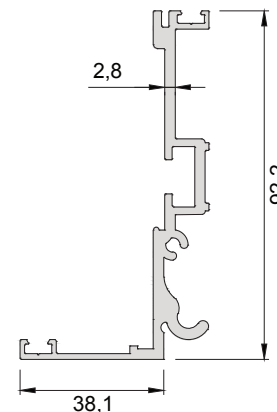

580-5102 ( 1,373 kg/mt )  
SRA150 A10 TRANSMISSION PROFILE

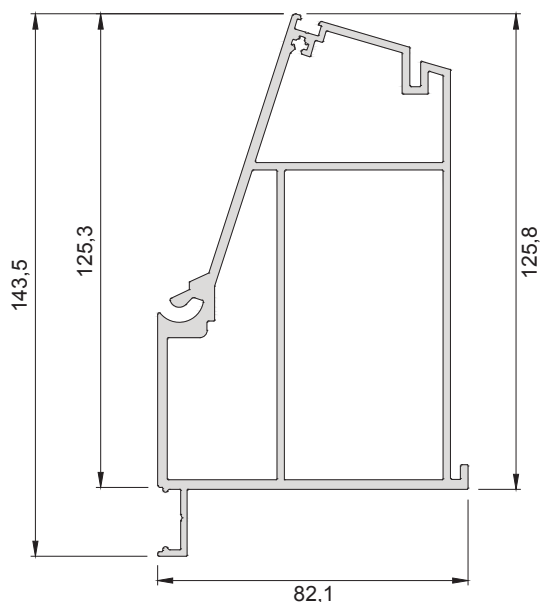

580-2101 ( 3,438 kg/mt )  
SRA150 T01 CHASSIS PROFILE

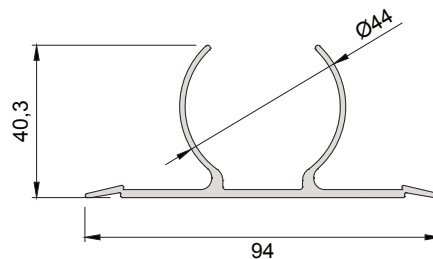

580-5101 ( 0,879 kg/mt )  
SRA150 A09 CONNECTION PROFILE

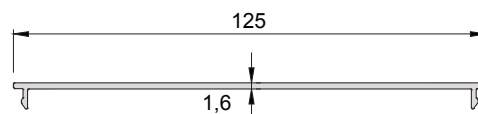

410-4004 ( 0,577 kg/mt )  
GSAL100 MOTOR BOX COVER PROFILE 125 mm

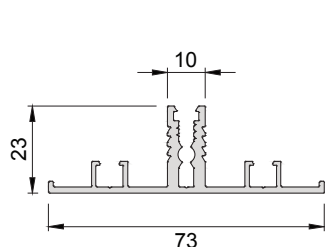

573-1101 ( 0,701 kg/mt )  
WGA73 MULION PROFILE

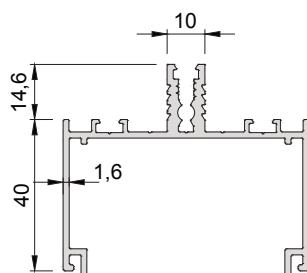

573-2101 ( 1,024 kg/mt )  
WGA73 TRANZOM PROFILE

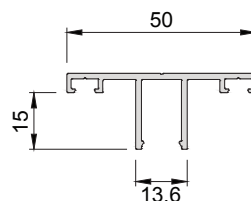

573-6101 ( 0,415 kg/mt )  
WGA73 COVER PROFILE

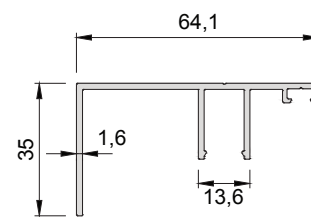

573-6102 ( 0,598 kg/mt )  
WGA73 COVER PROFILE

# WGA 73

## WINTERGARDEN SYSTEM

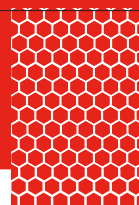

ACCURACY



HARMONY



BALANCE

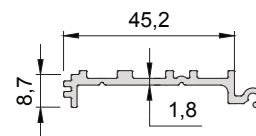
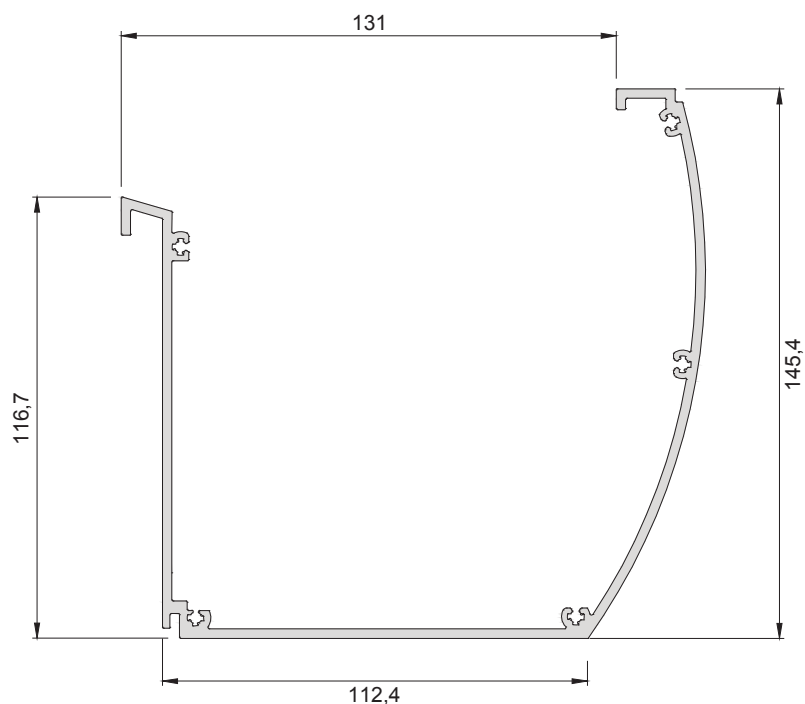

580-6205 ( 0,395 kg/mt )  
REAR FINISH PROFILE

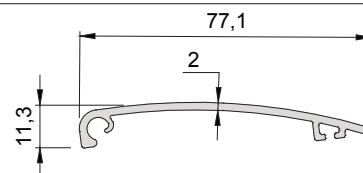

560-5102( 0,528 kg/mt )  
WALL ADAPTER PROFILE

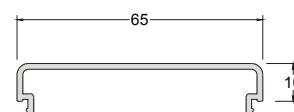

580-3101 ( 3,070 kg/mt )  
SRA150 A05 STREAM PROFILE

565-6501 ( 0,385 kg/mt )  
COVER PROFILE

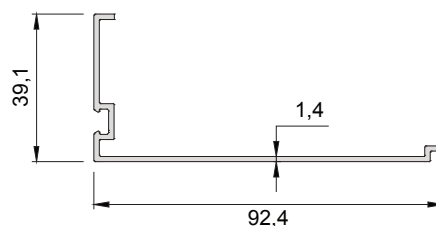
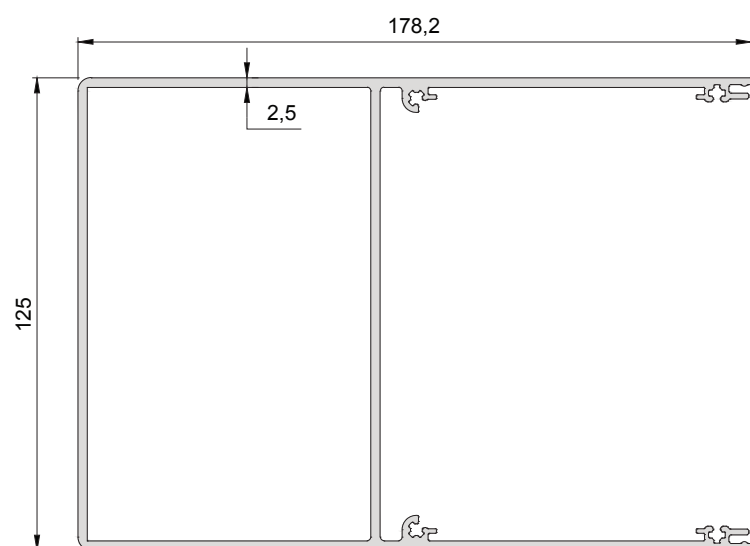

580-5103 ( 0,562 kg/mt )  
SRA150 A11 FRONT CLOSING PROFILE

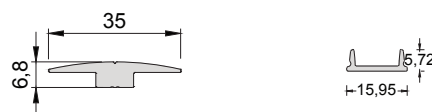

580-1103 ( 4,274 kg/mt )  
CARRIER SEWING PROFILE

550-6102 ( 0,316 kg/mt )  
W50P12 Safety cover

580-6107 ( 0,085 kg/mt )  
CHANNEL CLOSER

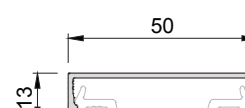
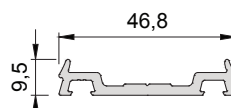
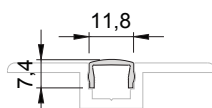
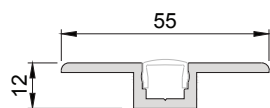

550-6103 ( 0,494 kg/mt )  
W50P09 COVER PROFILE 3 mm

550-6208 ( 0,041 kg/mt )  
W5009A Pressure Bar

550-6101 ( 0,425 kg/mt )  
W50P01 Print Profile

550-6201 ( 0,277 kg/mt )  
W50P03 COVER PROFILE 13 mm



ACCURACY

HARMONY

BALANCE

PRODUCT DRAWING	Product code	Product Name
	3202204	EXTERIOR GLASS WICK 3 mm
	3202127	INNER GLASS WICK 2,7 mm
	3202106	INNER GLASS WICK 4,7 mm
	3202107	INNER GLASS WICK 6,7 mm
	3202109	INNER GLASS WICK 10,7 mm
	3202137	wall finishing wick
	320xxxx	INSULATION WICK
	1601512	U Connection 46,5 mm

PRODUCT DRAWING	Product code	Product Name
	1601514	U Connection 46,5 mm
	1601515	L Connection 52,0 mm
	8003601	Filter 70 MM
	7903112	PVC GAGA izolator 12 mm
	7903108	PVC GAGA izolator 8 mm
	1601916	PVC CORNER WEDGE
	7903001	LED LIGHTING profile
	4101016	GLASS INTERMEDIATE 4S

PRODUCT DRAWING	Product code	Product Name
	1607401	CAM ARA U 4SU
	1601900	4S TESPİT İÇİN TEKLİ
	1601131	4SU TESPİT İÇİN 2 Lİ
	1601132	4SU TESPİT İÇİN TEKLİ
	1616415	MULYON KAPAK
	1616416	DERE KAPAK
	1616417	DUVAR BİTİM KAPAK
	1616418	DİKME YER FLANŞI

4.4 Laminated Glass  
0,38 Pvp

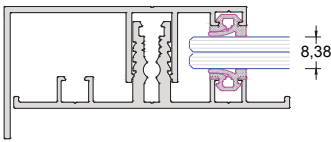

5.5 Laminated Glass  
0,76 Pvp

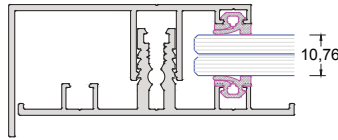

6.6 Laminated Glass  
1,52 Pvp

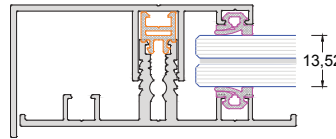

16 mm Polycarbon

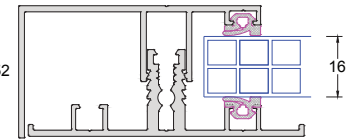

6+12HB+4.4 Laminated Heat Glass  
0,58 pvp

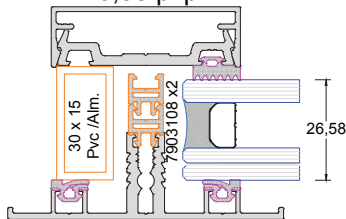

6+12HB+6 Heat Glass

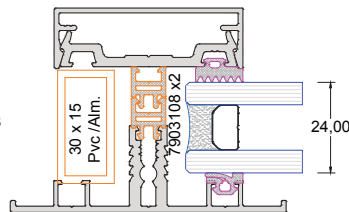

4+14+4 Heat Glass

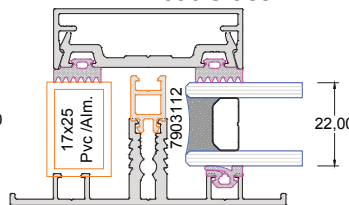

4+12+4 Heat Glass

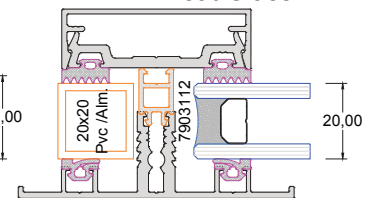

# WGA 73

## WINTERGARDEN SYSTEM



ACCURACY



HARMONY



BALANCE

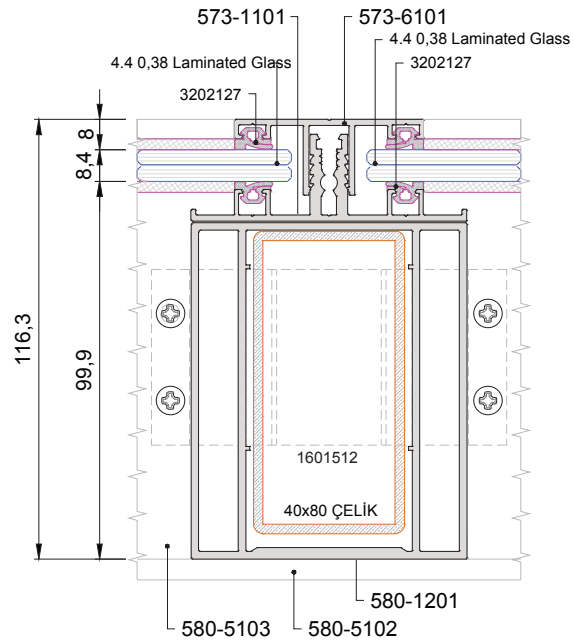
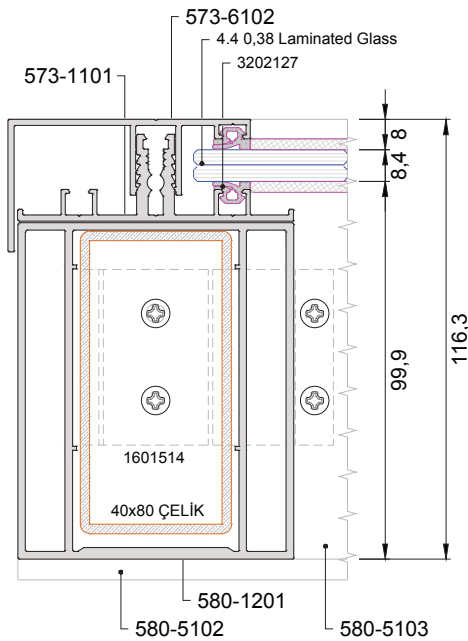
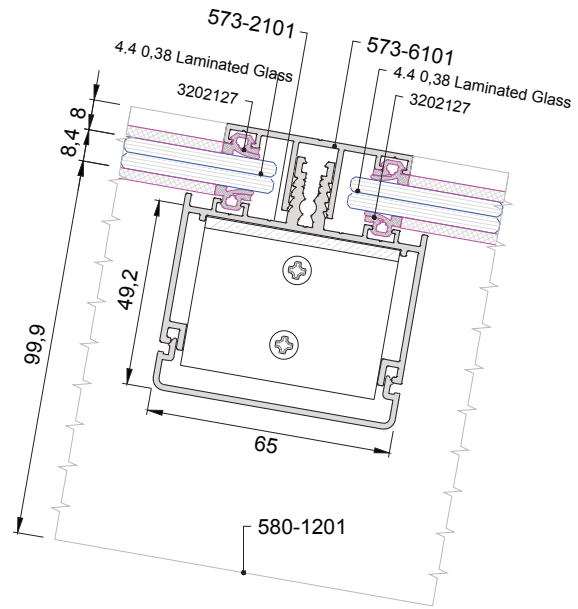
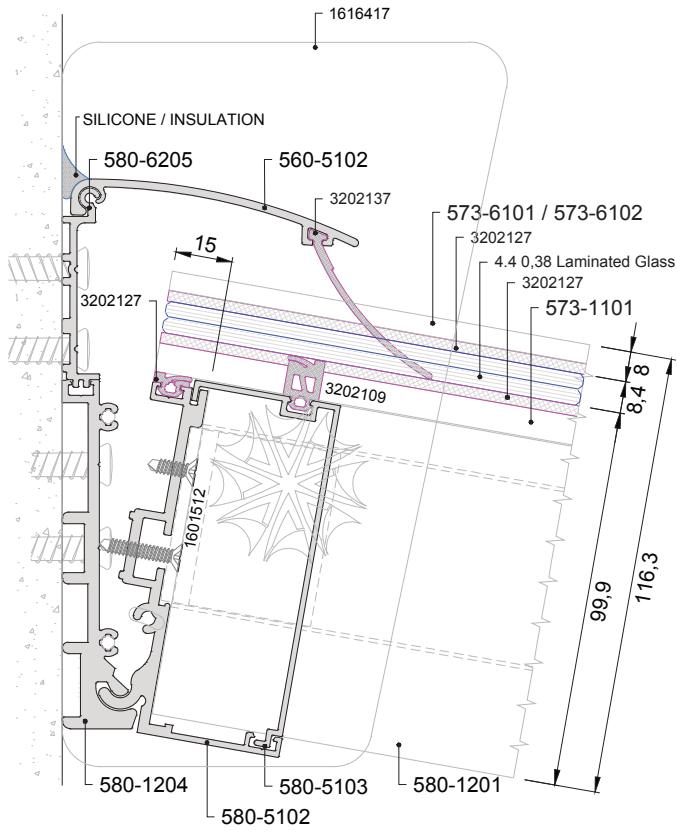

**IMPORTANT NOTE:** The 40x80 Steel Box Profile Depth size placed in Million profiles is 4.0 mt. It is mandatory to use in cases where it exceeds.

# WGA 73

WINTERGARDEN SYSTEM



ACCURACY



HARMONY



BALANCE

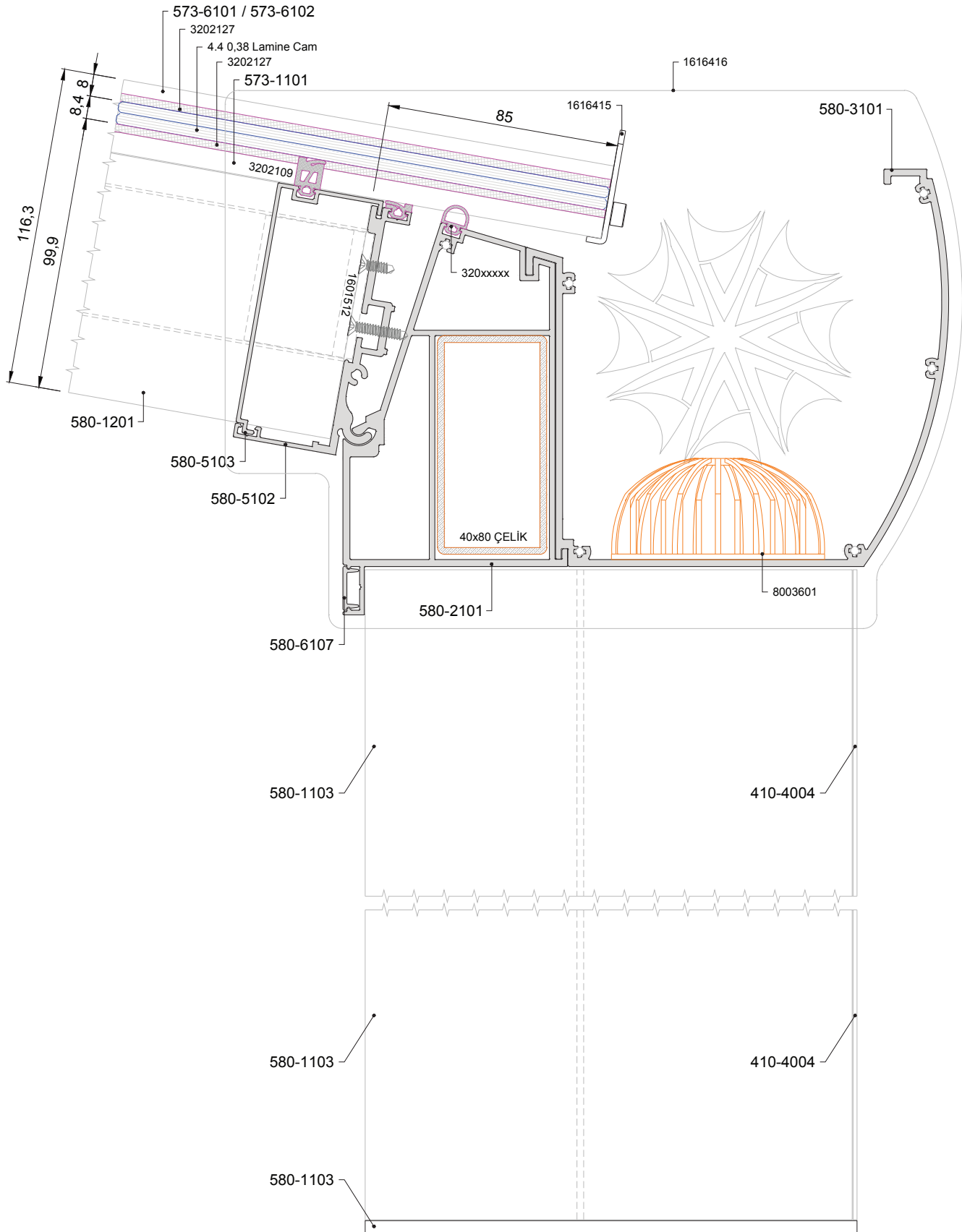

**IMPORTANT NOTE:** 40x80 Steel Box two Carrier Strut Profiles placed in ( 563-1102 ) Chassis Profile axle distance 4.0 mt. It is mandatory to use in cases where it exceeds.

# WGA 73

WINTERGARDEN SYSTEM



ACCURACY



HARMONY



BALANCE

