

EDITION / VERSİYON
05/2017

51LS

SLIDE & LIFT-SLIDE SYSTEM

SÜRME & KALDIR-SÜR SİSTEM

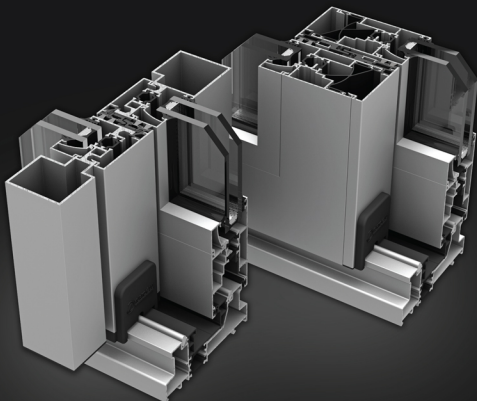

KURTOĞLU®
ALUMINIUM



LorenzoLine®
aluminium profile system

PROFILES / PROFILLER

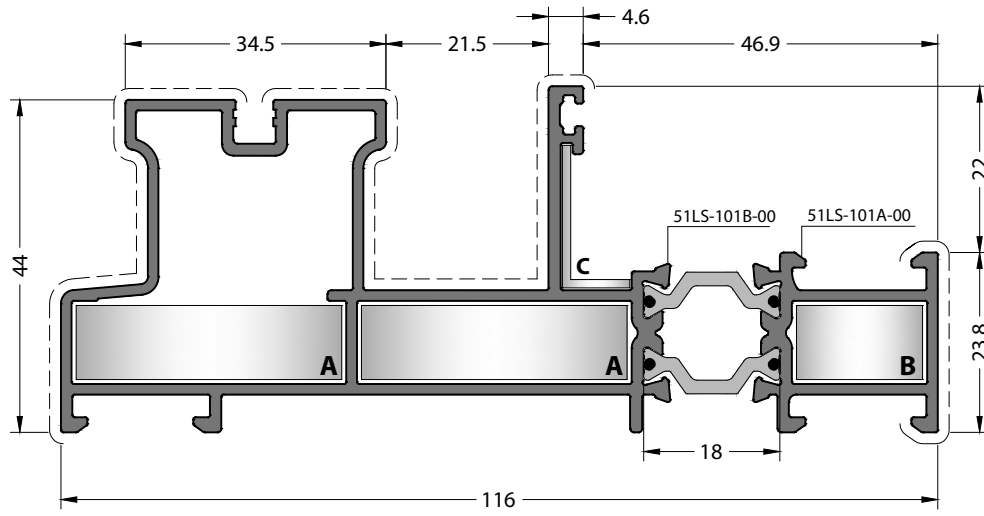

CODE / KOD
51LS-101-00

THEORETICAL WEIGHT kg/m
TEORİK AĞIRLIK kg/m
1.859

CORNER JOINTS
KÖŞE BAĞLANTILAR



A CC-101-35.7



B CC-101-17.3



C EM51-21

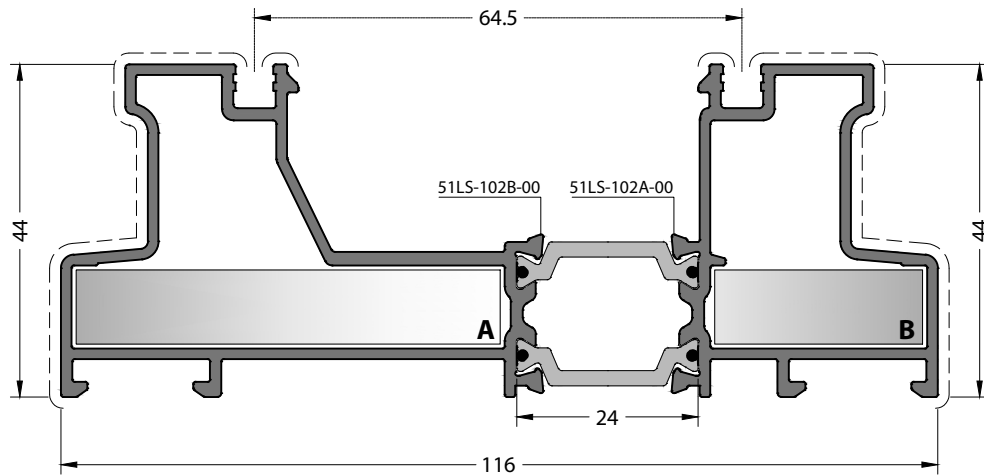

CODE / KOD
51LS-102-00

THEORETICAL WEIGHT kg/m
TEORİK AĞIRLIK kg/m
1.819

CORNER JOINTS
KÖŞE BAĞLANTILAR



A CC-101-56.7



B CC-101-28.1

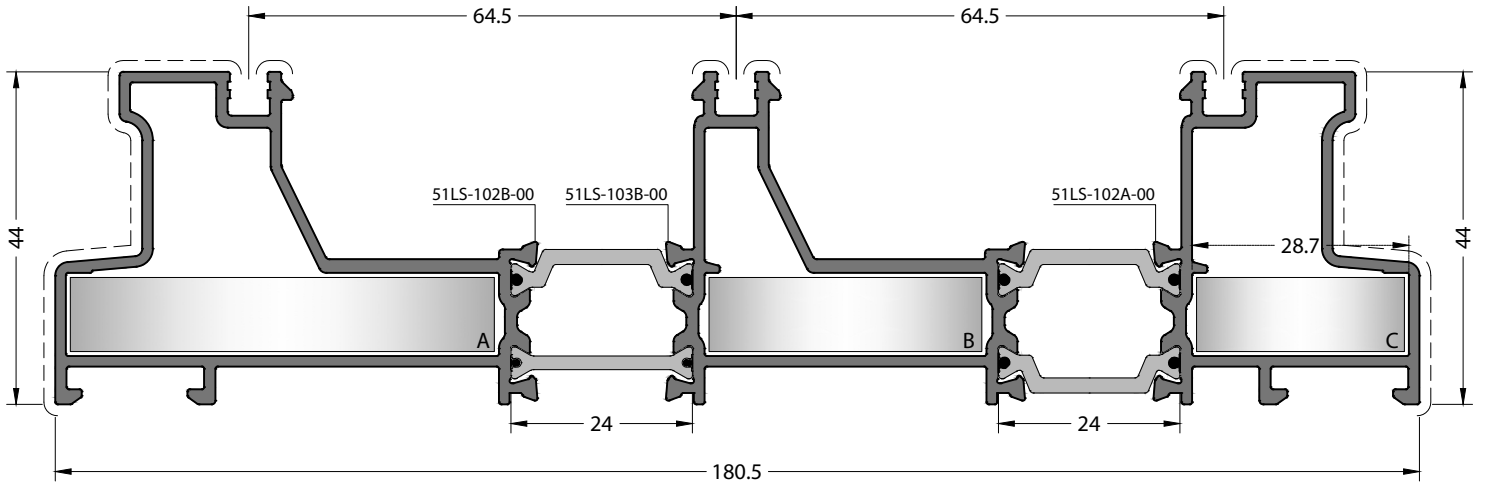

CODE / KOD
51LS-103-00

THEORETICAL WEIGHT kg/m
TEORİK AĞIRLIK kg/m
2.777

CORNER JOINTS
KÖŞE BAĞLANTILAR



A CC-101-56.7



B CC-101-36.7



C CC-101-28.1

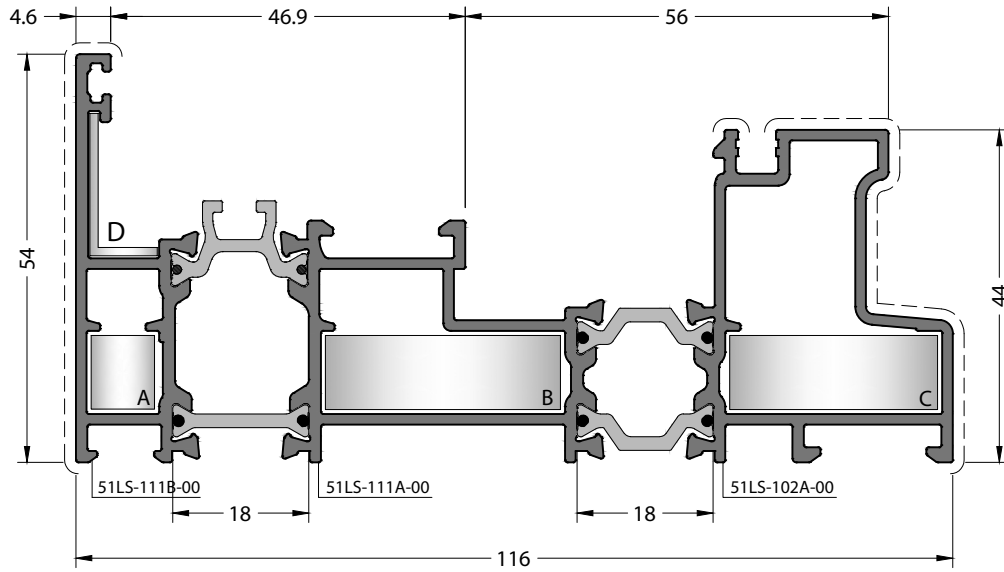

CODE / KOD
51LS-111-00

THEORETICAL WEIGHT kg/m
TEORİK AĞIRLIK kg/m

2.206

CORNER JOINTS
KÖŞE BAĞLANTILAR



A CC-101-9



B CC-101-31.7



C CC-101-28.1



D EM51-21

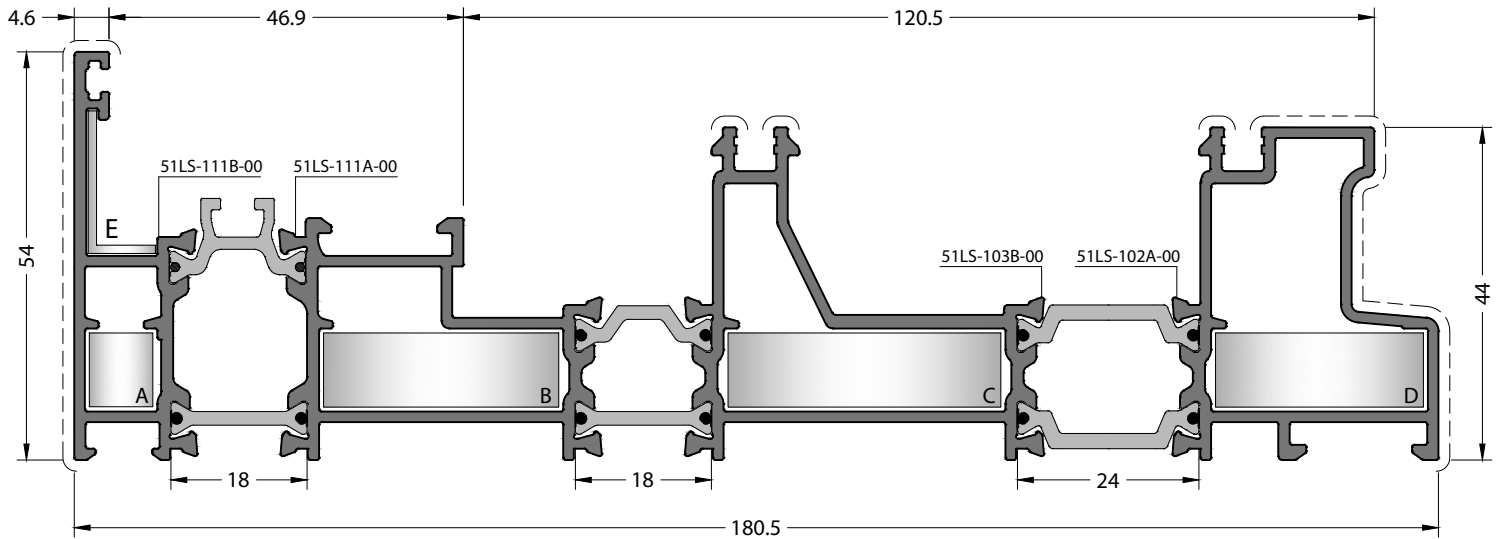

CODE / KOD
51LS-112-00

THEORETICAL WEIGHT kg/m
TEORİK AĞIRLIK kg/m

3.159

CORNER JOINTS
KÖŞE BAĞLANTILAR



A CC-101-9



B CC-101-31.7



C CC-101-36.7



D CC-101-28.1



E EM51-21

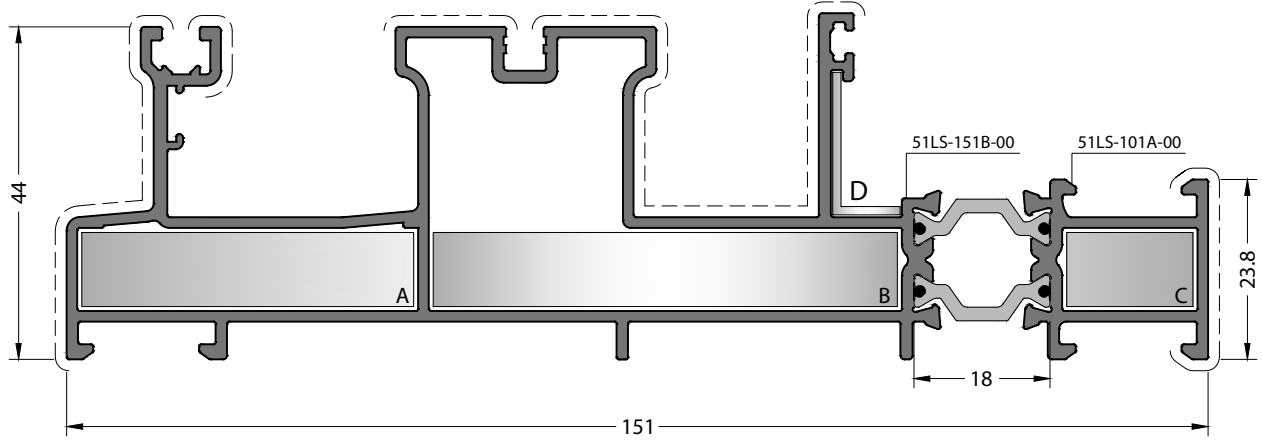

CODE / KOD
51LS-151-00

THEORETICAL WEIGHT kg/m
TEORİK AĞIRLIK kg/m
2.337

CORNER JOINTS
KÖŞE BAĞLANTILAR



A CC-101-44.5



B CC-101-62



C CC-101-17.3



D EM51-21

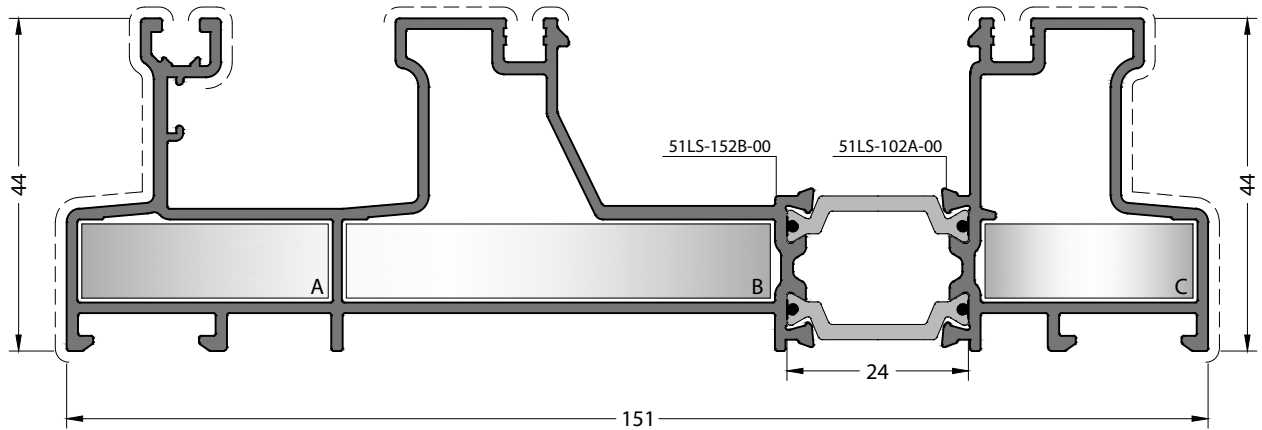

CODE / KOD
51LS-152-00

THEORETICAL WEIGHT kg/m
TEORİK AĞIRLIK kg/m
2.337

CORNER JOINTS
KÖŞE BAĞLANTILAR



A CC-101-33.2



B CC-101-56.7



C CC-101-28.1

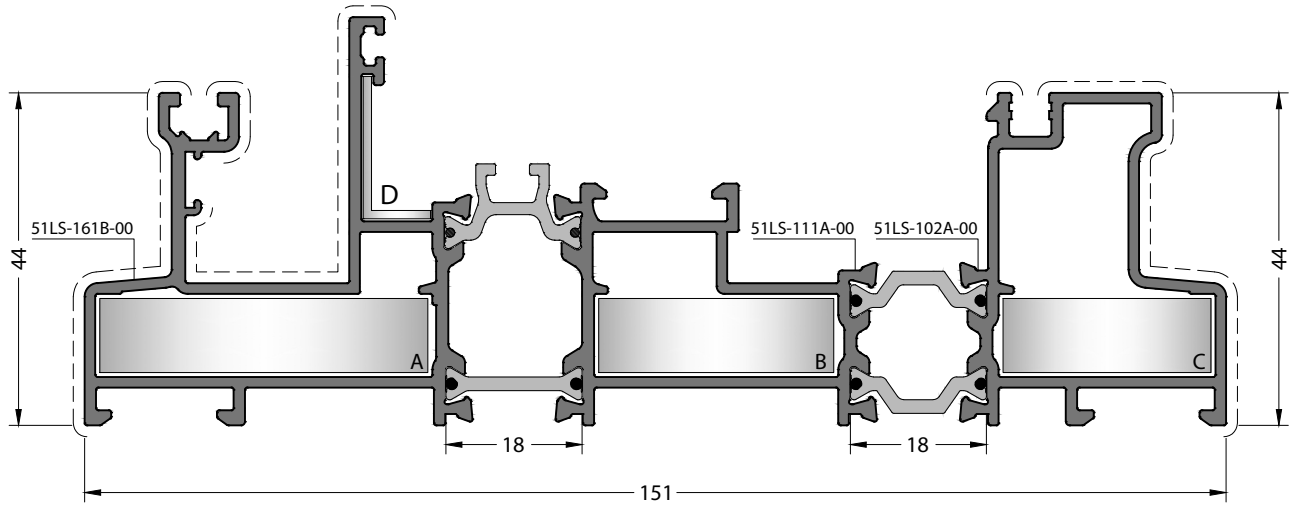

CODE / KOD
51LS-153-00

THEORETICAL WEIGHT kg/m
TEORİK AĞIRLIK kg/m
2.694

CORNER JOINTS
KÖŞE BAĞLANTILAR



A CC-101-44



B CC-101-31.7



C CC-101-28.1



D EM51-21

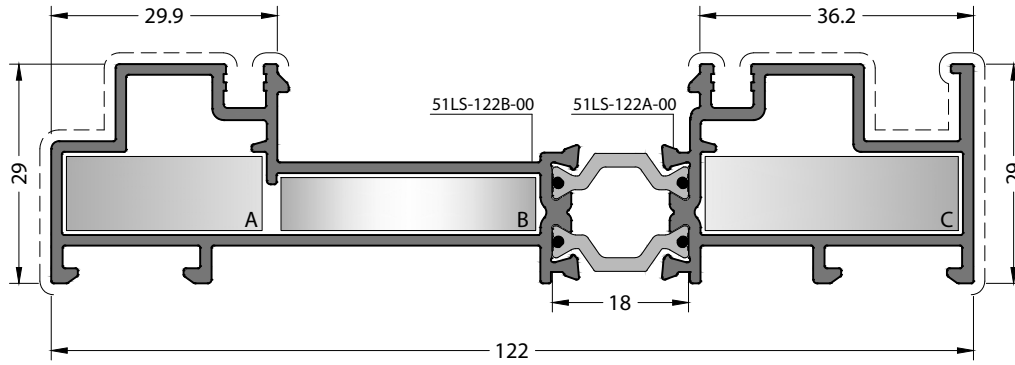

CODE / KOD
51LS-122-00

THEORETICAL WEIGHT kg/m
TEORİK AĞIRLIK kg/m
1.680

CORNER JOINTS
KÖŞE BAĞLANTILAR

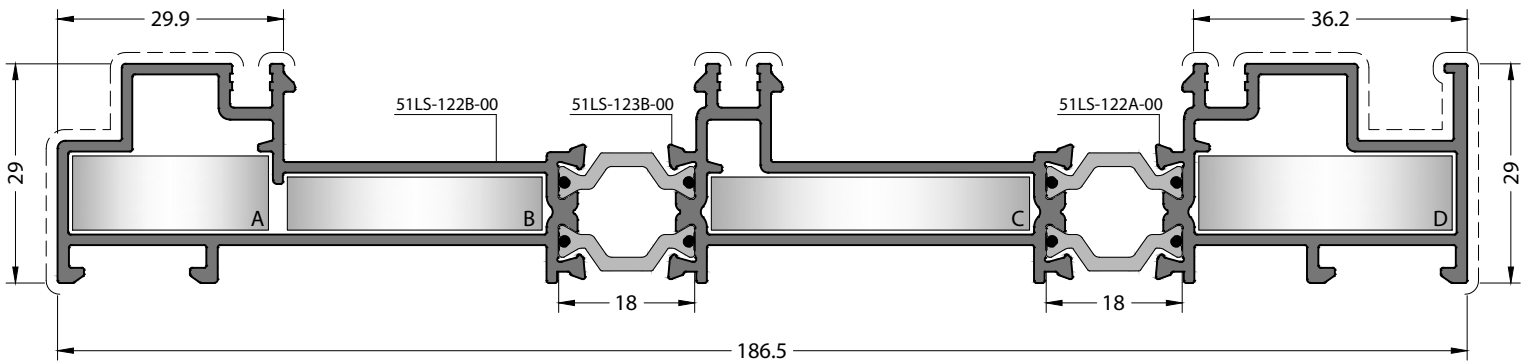
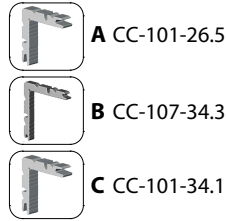

CODE / KOD
51LS-123-00

THEORETICAL WEIGHT kg/m
TEORİK AĞIRLIK kg/m
2.529

CORNER JOINTS
KÖŞE BAĞLANTILAR

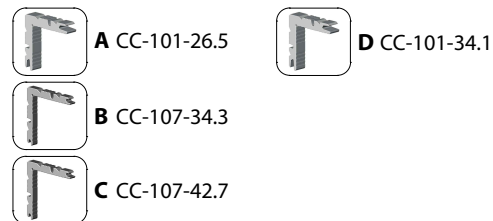

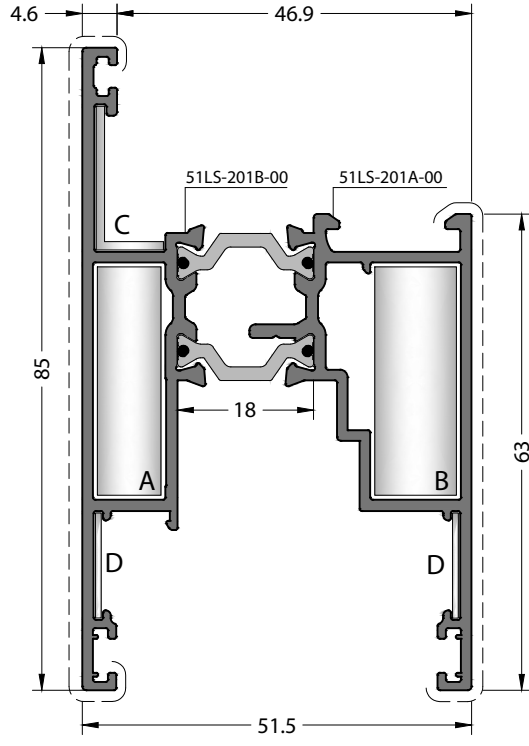

CODE / KOD
51LS-201-00

THEORETICAL WEIGHT kg/m
TEORİK AĞIRLIK kg/m
1.522

CORNER JOINTS
KOŞE BAĞLANTILAR



A CC-104-09.0



B CC-104-11.4



C EM51-21



D MK-20.1

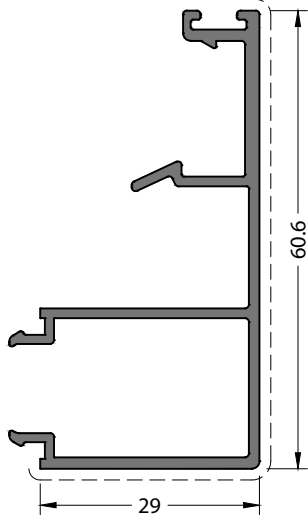

CODE / KOD
51LS-401-00
THEORETICAL WEIGHT kg/m
TEORİK AĞIRLIK kg/m
0.632

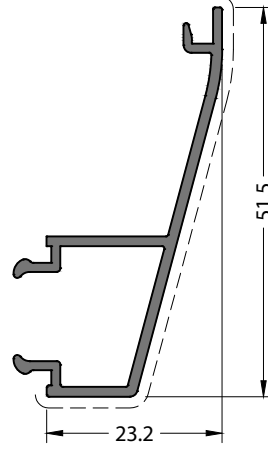

CODE / KOD
51LS-411-00
THEORETICAL WEIGHT kg/m
TEORİK AĞIRLIK kg/m
0.369

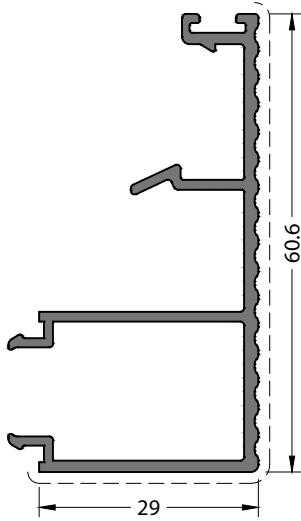

CODE / KOD
51LS-402-00
THEORETICAL WEIGHT kg/m
TEORİK AĞIRLIK kg/m
0.639

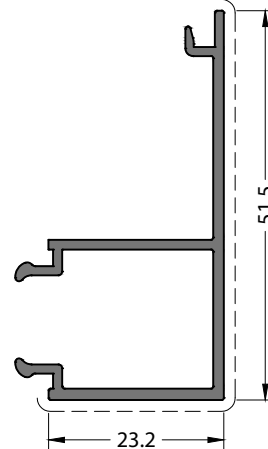

CODE / KOD
51LS-412-00
THEORETICAL WEIGHT kg/m
TEORİK AĞIRLIK kg/m
0.435

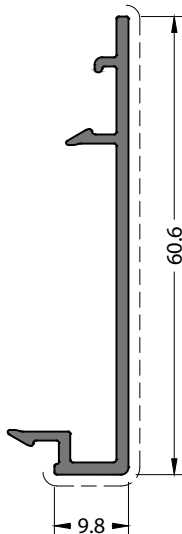

CODE / KOD
51LS-501-00
THEORETICAL WEIGHT kg/m
TEORİK AĞIRLIK kg/m
0.369

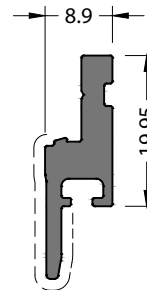

12 Micron Matte Black Anodized.
12 Mikron Mat Siyah Eloksal.
CODE / KOD
51LS-502-00
THEORETICAL WEIGHT kg/m
TEORİK AĞIRLIK kg/m
0.325

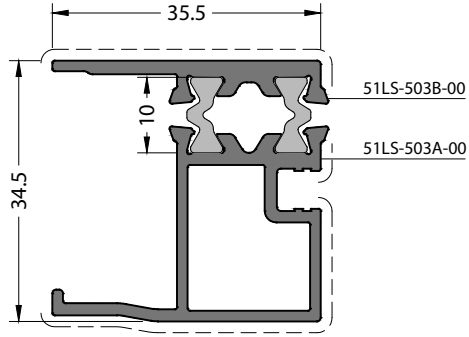

CODE / KOD
51LS-503-00

THEORETICAL WEIGHT kg/m
TEORİK AĞIRLIK kg/m
0.822

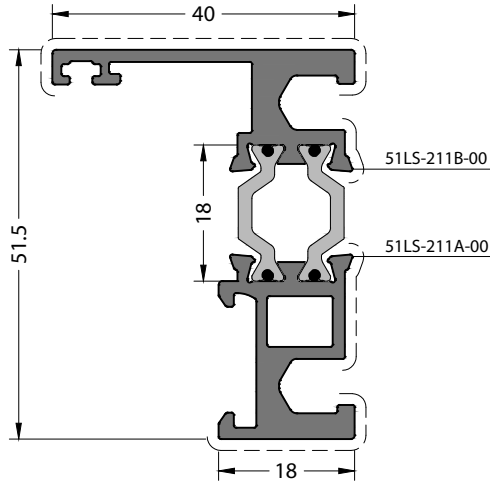

CODE / KOD
51LS-211-00

THEORETICAL WEIGHT kg/m
TEORİK AĞIRLIK kg/m
1.103

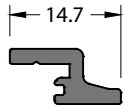

Mill Finish / Pres
No visible surface. / Görünen yüzeyi yoktur.

CODE / KOD
51LS-511-00

THEORETICAL WEIGHT kg/m
TEORİK AĞIRLIK kg/m
0.122

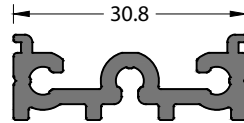

Mill Finish / Pres
No visible surface. / Görünen yüzeyi yoktur.

CODE / KOD
51LS-911-00

THEORETICAL WEIGHT kg/m
TEORİK AĞIRLIK kg/m
0.394

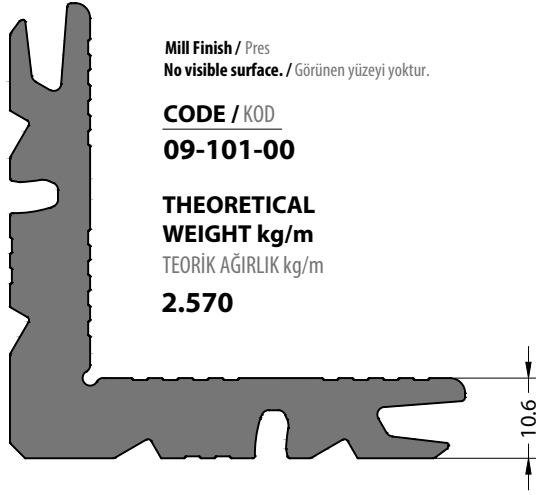

Mill Finish / Pres
No visible surface. / Görünen yüzeyi yoktur.

CODE / KOD
09-101-00

THEORETICAL
WEIGHT kg/m
TEORİK AĞIRLIK kg/m
2.570

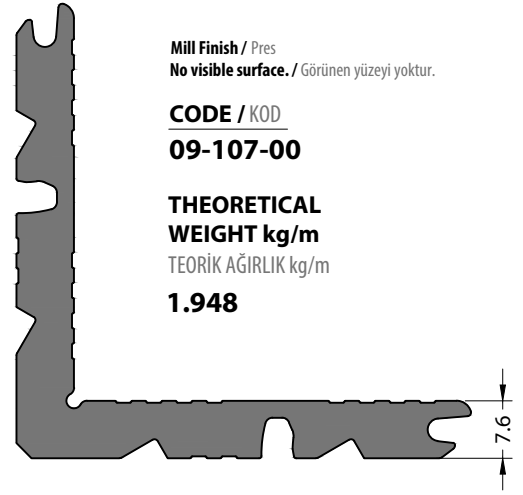

Mill Finish / Pres
No visible surface. / Görünen yüzeyi yoktur.

CODE / KOD
09-107-00

THEORETICAL
WEIGHT kg/m
TEORİK AĞIRLIK kg/m
1.948

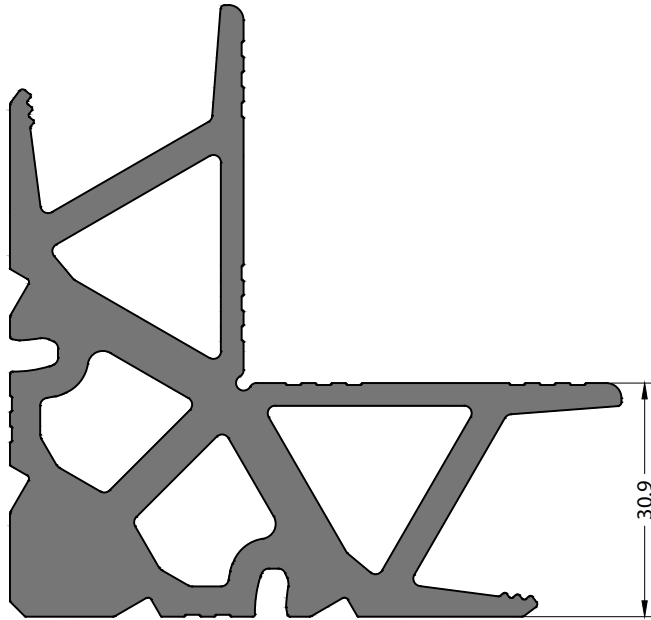

Mill Finish / Pres
No visible surface. / Görünen yüzeyi yoktur.

CODE / KOD
09-104-00

THEORETICAL
WEIGHT kg/m
TEORİK AĞIRLIK kg/m
4.603

DETAILS / DETAYLAR

