

BR^L

Aluminium System

**SYSTEM
CASTLE**

16'55 W

**ARCHITECTURAL
CATALOGUE**

BR^L
Aluminium System

SYSTEM CASTLE 16'55 W

b - PROFILE

		FRAME PROFILE 25 / 47			
		PROFILE CODE 16FW01		THEORETICAL WEIGHT kg/mtr 1.078	
J _{xx} (cm ⁴)	J _{yy} (cm ⁴)	Coating Surface (cm)		Covering Surface (cm)	
—	—	—		Inside	Outside
—	—	—		—	—
CORNER CLEATS		A	B	C	D
PRESS CORNER		—	—	—	—
DIE-CAST CORNER JOINT		—	—	M.A.11 2000	—
STEEL CORNER JOINT		—	—	—	—



* The weights are theoretical of presed profiles.

* When profiles are powder coated weight may increase by % 4 .

* Unless otherwise indicated , all dimensions in this catalogue are ± 0.1 mm and weights may vary by % 4 .

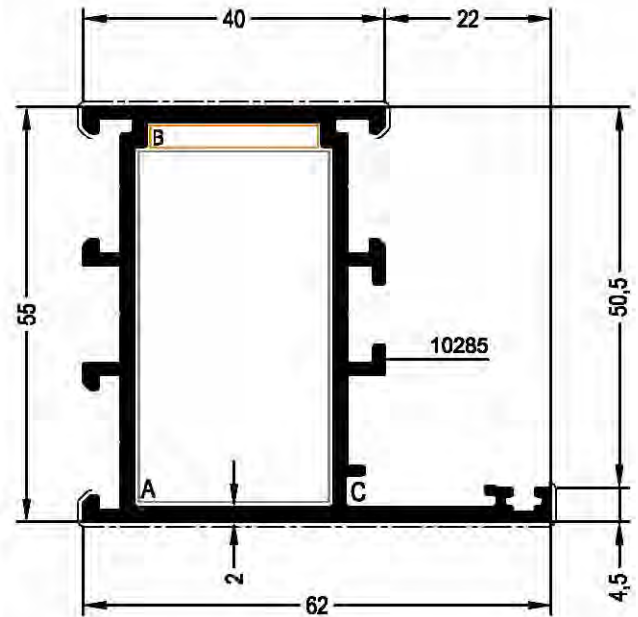
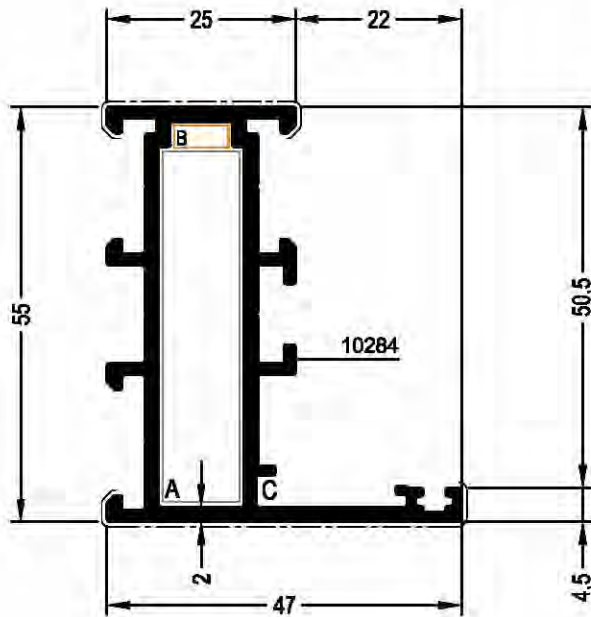

FRAMES

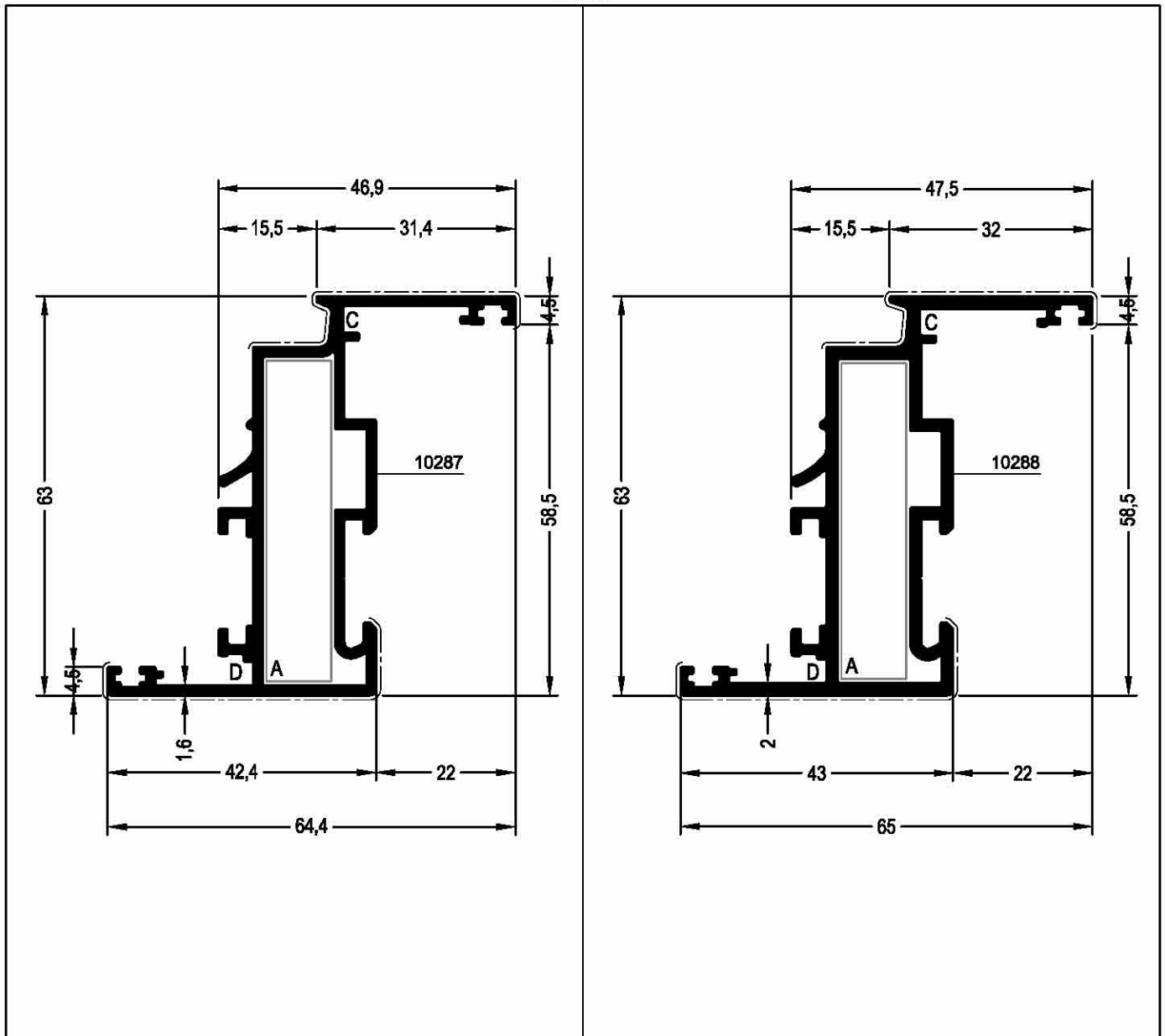

FRAME PROFILE 25 / 47					FRAME PROFILE 40 / 62						
PROFILE CODE		16FW01			THEORETICAL WEIGHT kg/mt		1.062				
PROFILE CODE		16FW02			THEORETICAL WEIGHT kg/mt		1.224				
J _{xx} (cm ⁴)	J _{yy} (cm ⁴)	Coating Surface (cm)		Covering Surface (cm)		J _{xx} (cm ⁴)	J _{yy} (cm ⁴)	Coating Surface (cm)		Covering Surface (cm)	
		10284		Inside	Outside			10285		Inside	Outside
15.552	4.051	31.762		3.465	5.722	20.760	10.704	34.762		4.965	7.222
CORNER CLEATS		A	B	C	D	CORNER CLEATS		A	B	C	D
PRESS CORNER		14LW14	—	—	—	PRESS CORNER		14LW32	—	—	—
DIE-CAST CORNER JOINT		—	—	M.fuji 2000	—	DIE-CAST CORNER JOINT		—	—	M.fuji 2000	—
P.V.C. CORNER JOINT		—	P.V.C.	—	—	P.V.C. CORNER JOINT		—	P.V.C.	—	—

VENTS



VENT PROFILE 42.4					VENT PROFILE 43						
PROFILE CODE		16VW01			THEORETICAL WEIGHT kg/mt		1.111				
J _{xx} (cm ⁴)	J _{yy} (cm ⁴)	Coating Surface (cm)		Covering Surface (cm)		J _{xx} (cm ⁴)	J _{yy} (cm ⁴)	Coating Surface (cm)		Covering Surface (cm)	
		10287		Inside	Outside			10288		Inside	Outside
23.377	4.213	36.546		6.032	5.794	26.646	4.883	36.617		6.092	5.970
CORNER CLEATS		A	B	C	D	CORNER CLEATS		A	B	C	D
PRESS CORNER		14LW14	—	—	—	PRESS CORNER		14LW14	—	—	—
DIE-CAST CORNER JOINT		—	—	M.fuji 2000	—	DIE-CAST CORNER JOINT		—	—	M.fuji 2000	—
P.V.C. CORNER JOINT		—	—	—	MO 20	P.V.C. CORNER JOINT		—	—	—	MO 20

VENTS

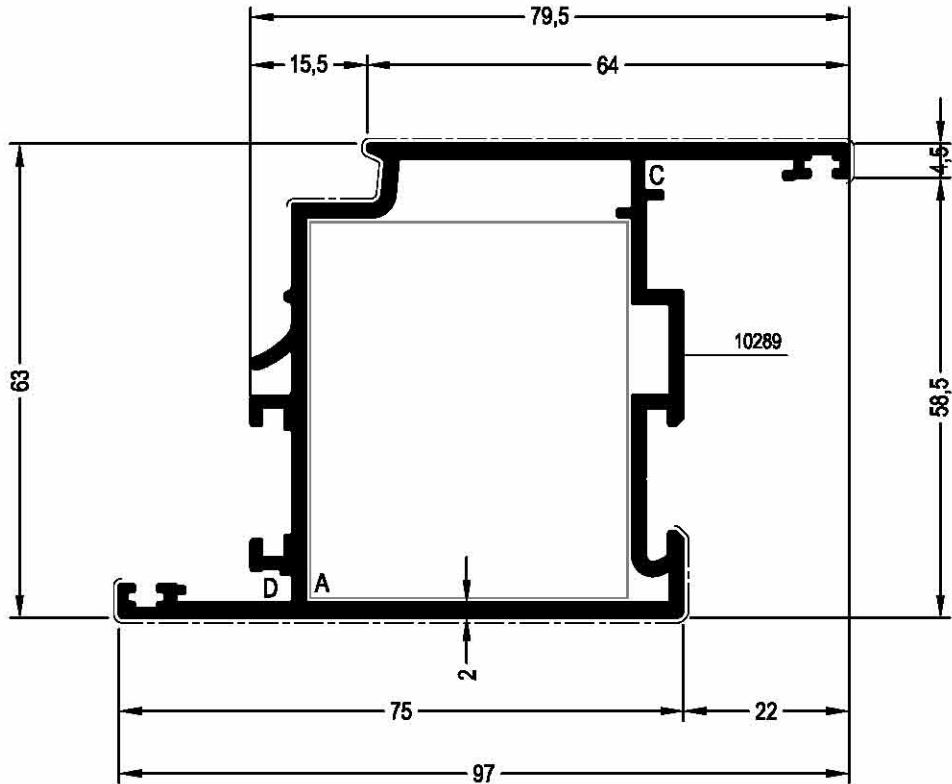

VENT PROFILE 75					
PROFILE CODE		16VW03	THEORETICAL WEIGHT kg/mt		
		1.652			
Jxx (cm ⁴)	Jyy (cm ⁴)	Coating Surface (cm)		Covering Surface (cm)	
		10289		Inside	Outside
50.134	23.320	42.965	9.054	9.292	
CORNER CLEATS		A	B	C	D
PRESS CORNER		14LW33	—	—	—
DIE-CAST CORNER JOINT		—	—	M.fuji 2000	—
P.V.C. CORNER JOINT		—	—	—	MO 20

VENTS

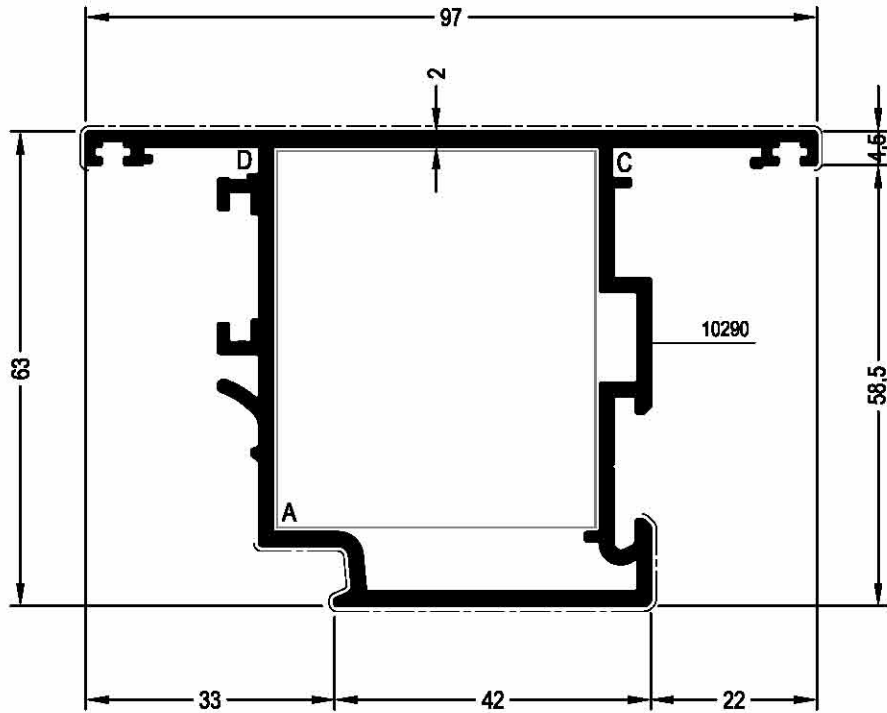

VENT PROFILE 42					
PROFILE CODE		16VW04		THEORETICAL WEIGHT kg/mt	
				1.652	
Jxx (cm ⁴)	Jyy (cm ⁴)	Coating Surface (cm)		Covering Surface (cm)	
		10290		Inside Outside	
38.994	32.626	42.965	10.779	7.567	
CORNER CLEATS		A	B	C	D
PRESS CORNER		14LW33	—	—	—
DIE-CAST CORNER JOINT		—	—	M.fuji 2000	—
P.V.C. CORNER JOINT		—	—	—	MO 20

MULLION

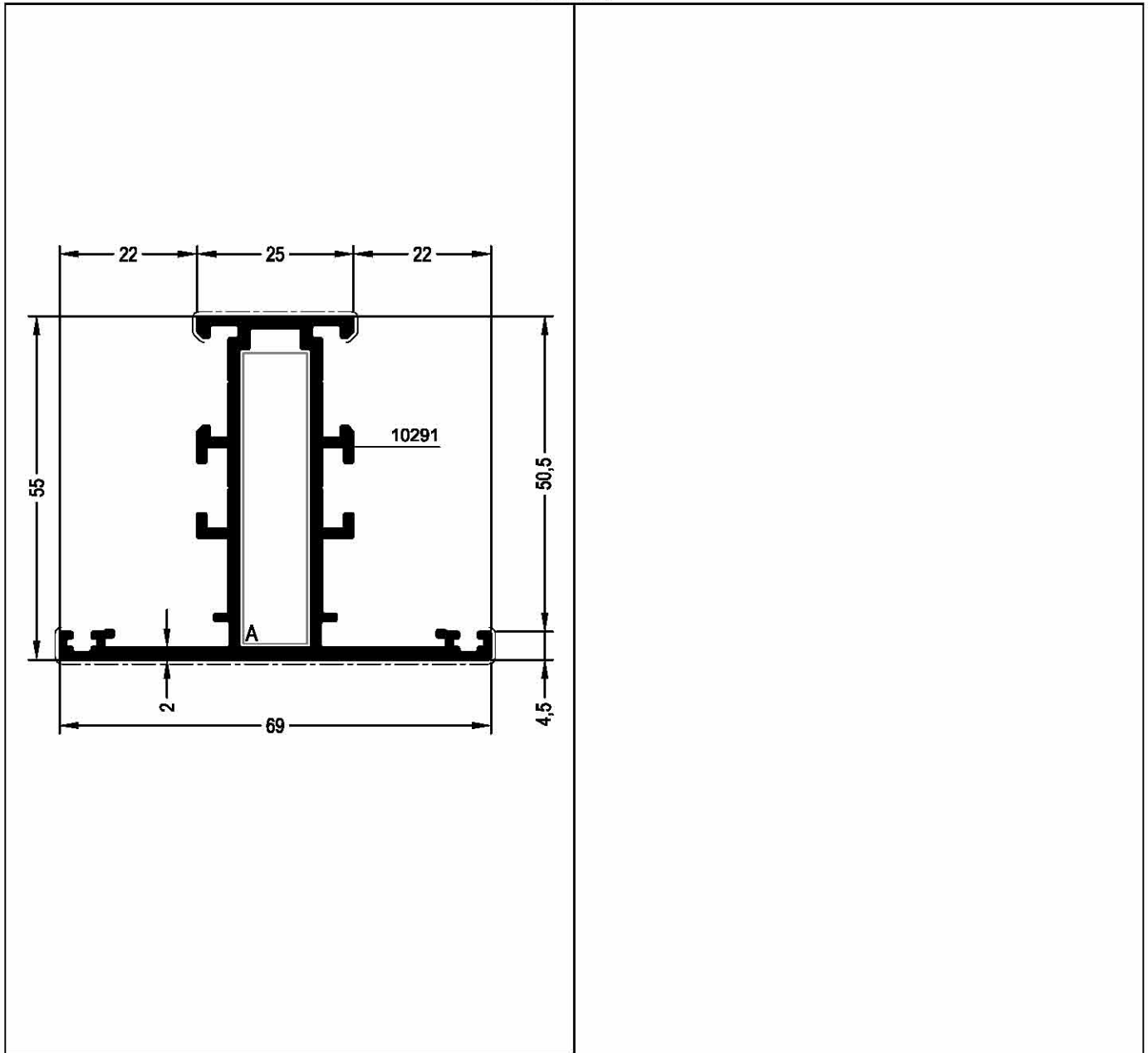

TRANSOM MULLION PROFILE 25 / 69					
PROFILE CODE		16MW01		THEORETICAL WEIGHT kg/mt	
				1.215	
Jxx (cm ⁴)	Jyy (cm ⁴)	Coating Surface (cm)		Covering Surface (cm)	
		10291		Inside	Outside
17.260	8.565	39.557		3.465	7.979
T JUNCTION		A		C	
		14JW10		—	
CORNER CLEATS		A		C	
		14LW14		M.fuji 2000	

MULLION

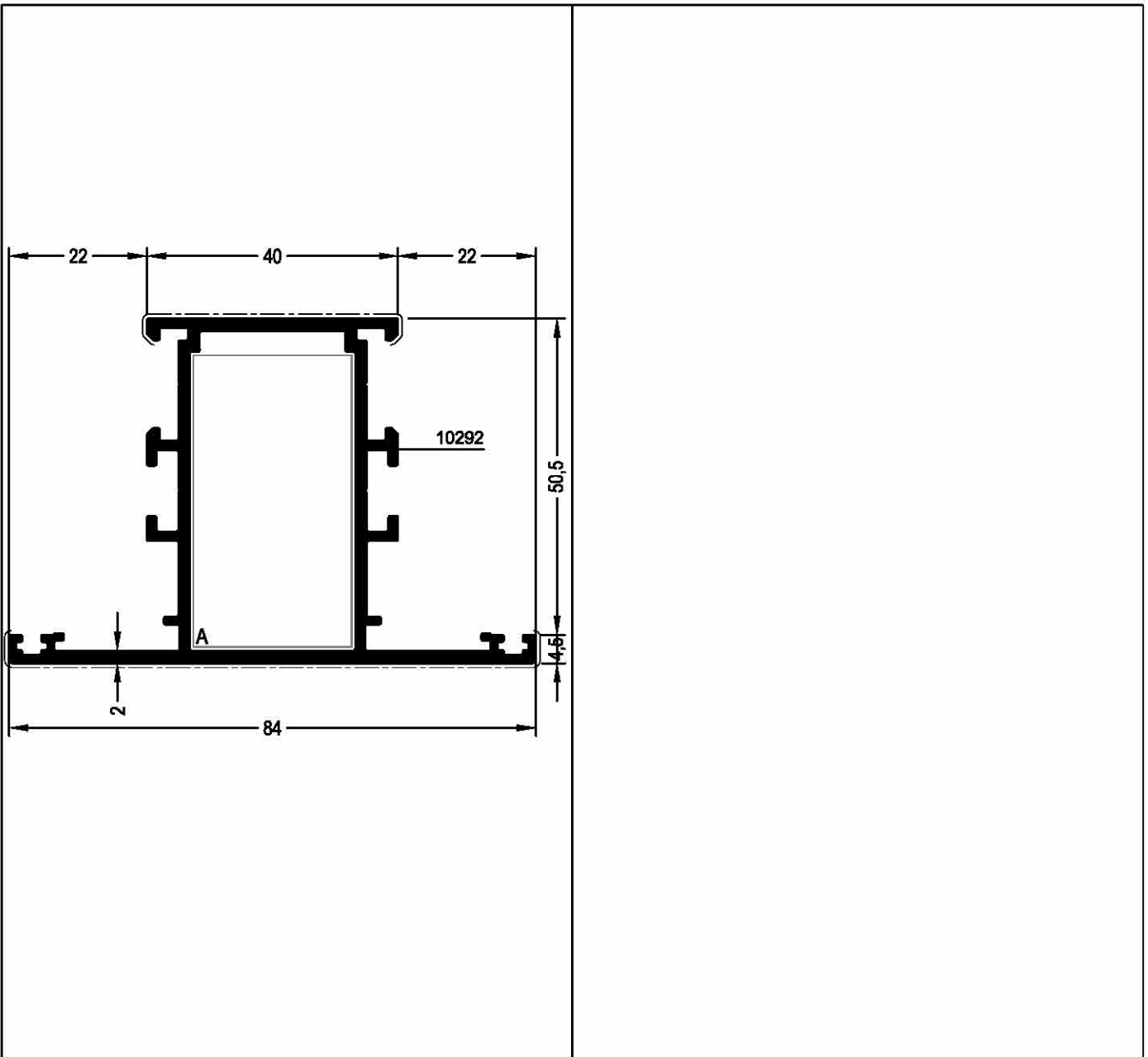

TRANSOM MULLION PROFILE 40 / 84



PROFILE CODE		16MW02		THEORETICAL WEIGHT kg/mt	
				1.378	
J _{xx} (cm ⁴)	J _{yy} (cm ⁴)	Coating Surface (cm)		Covering Surface (cm)	
		10292		Inside	Outside
21.649	18.671	41.557	4.965	9.479	
T JUNCTION		A		C	
		14JW10		—	
CORNER CLEATS		A		C	
		14LW32		M.fuji 2000	

KICK PLATE

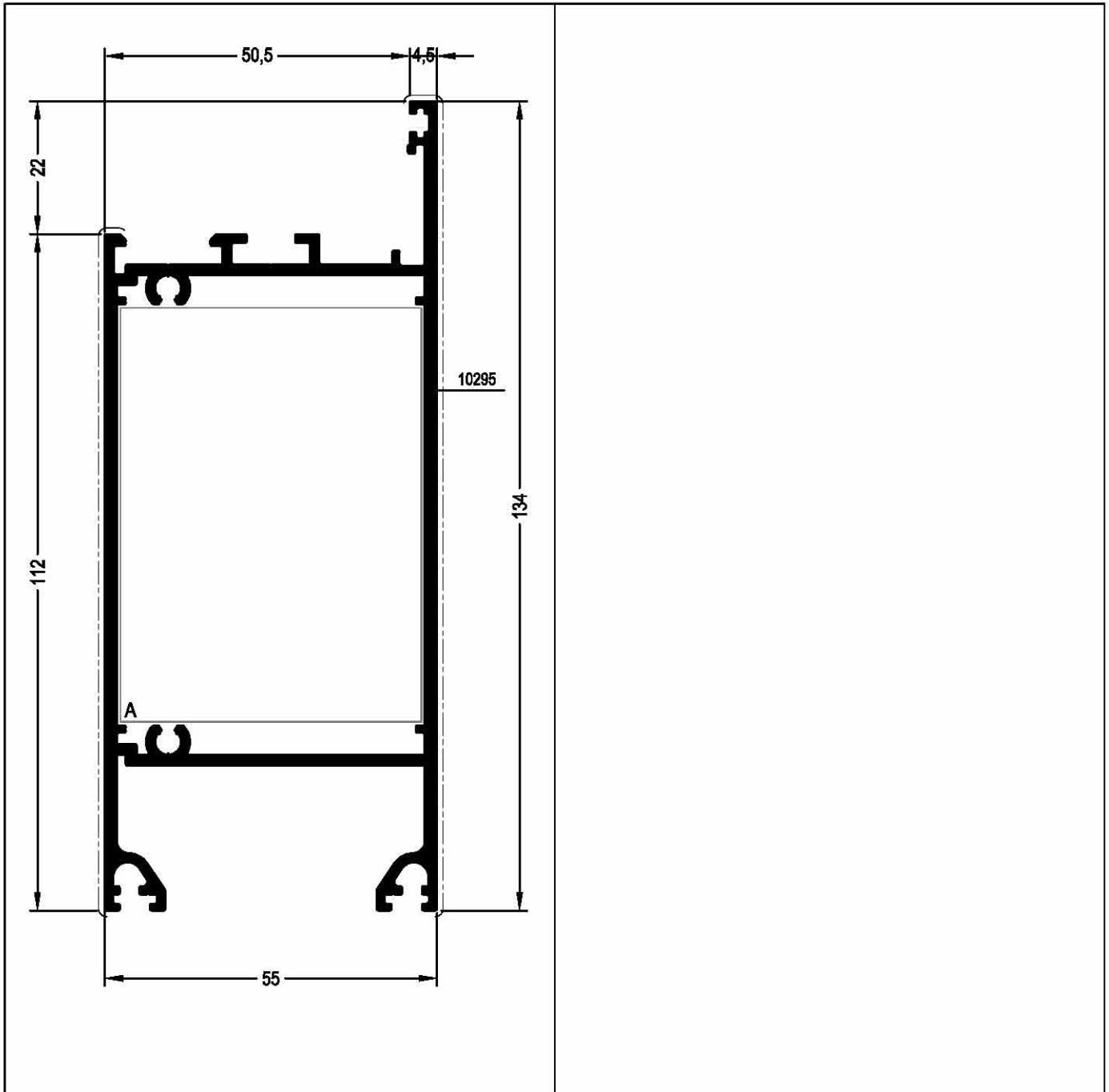

KICK PLATE PROFILE 112 / 134



PROFILE CODE		16KW02		THEORETICAL WEIGHT kg/mt	
				2.183	
J _{xx} (cm ⁴)	J _{yy} (cm ⁴)	Coating Surface (cm)	Covering Surface (cm)		
		10295	Inside	Outside	
---	---	56.338	11.583	14.004	
T JUNCTION		A		C	
		14JW09		---	

KICK PLATE

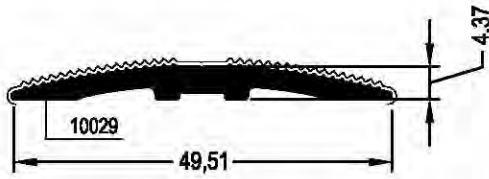

THRESHOLD PROFILE

PROFILE CODE	12KW03	THEORETICAL WEIGHT kg/mt
		0.354
Coating Surface (cm)	11.405	

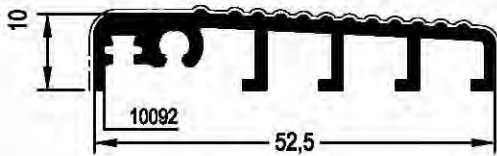

THRESHOLD PROFILE

PROFILE CODE	11KW02	THEORETICAL WEIGHT kg/mt
		0.465
Coating Surface (cm)	22.117	

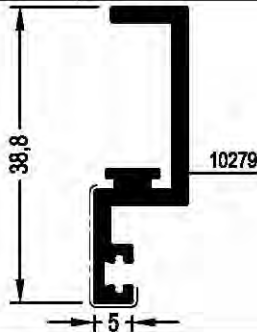

KICK PLATE PROFILE

PROFILE CODE	17AW16	THEORETICAL WEIGHT kg/mt	
		0.422	
Coating Surface (cm)	14.314	Covering Surface (cm)	2.359

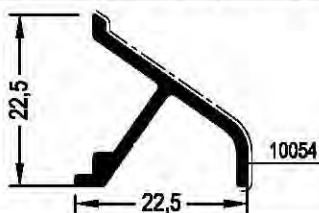

DRAINAGE PROFILE

PROFILE CODE	14PW01	THEORETICAL WEIGHT kg/mt
		0.190
Coating Surface (cm)	10.183	

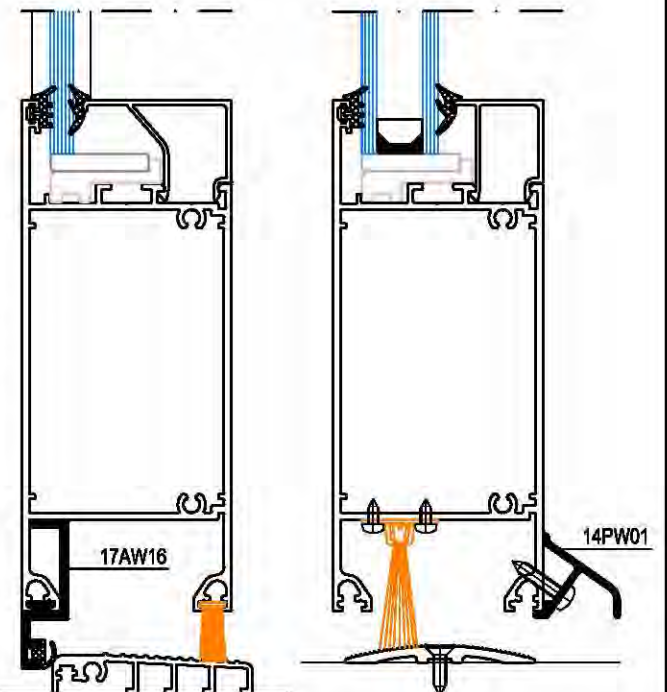
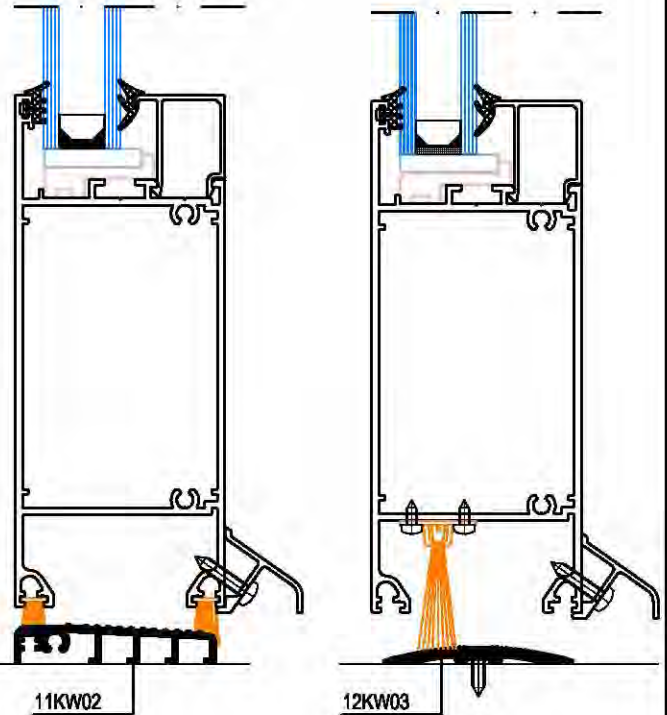

ADAPTERS



ADAPTER 61.5 / 60.25					ADAPTER 57.15 / 55							
PROFILE CODE		16AW02			THEORETICAL WEIGHT kg/mt		1.165		ADAPTER 57.15 / 55			
PROFILE CODE		16AW03			THEORETICAL WEIGHT kg/mt		1.062		ADAPTER 57.15 / 55			
Jxx (cm ⁴)	Jyy (cm ⁴)	Coating Surface (cm)		Covering Surface (cm)		Jxx (cm ⁴)	Jyy (cm ⁴)	Coating Surface (cm)		Covering Surface (cm)		
—	—	10293		Inside	Outside	—	—	10294		Inside	Outside	
—	—	33.718		1.966	7.608	—	—	29.857		6.294	1.418	
APPLICATION PROFILE		16VW01, 16VW02, 16VW03, 16VW04, 16VW05			CORNER CLEATS				A		C	
FACE CAP		TOP			BOTTOM		APPLICATION PROFILE		14LW32		M.fuji 2000	
—		—			—		16FW01, 16FW02, 16FW03, 16MW01, 16MW02, 16VW04		—		—	

ADAPTER

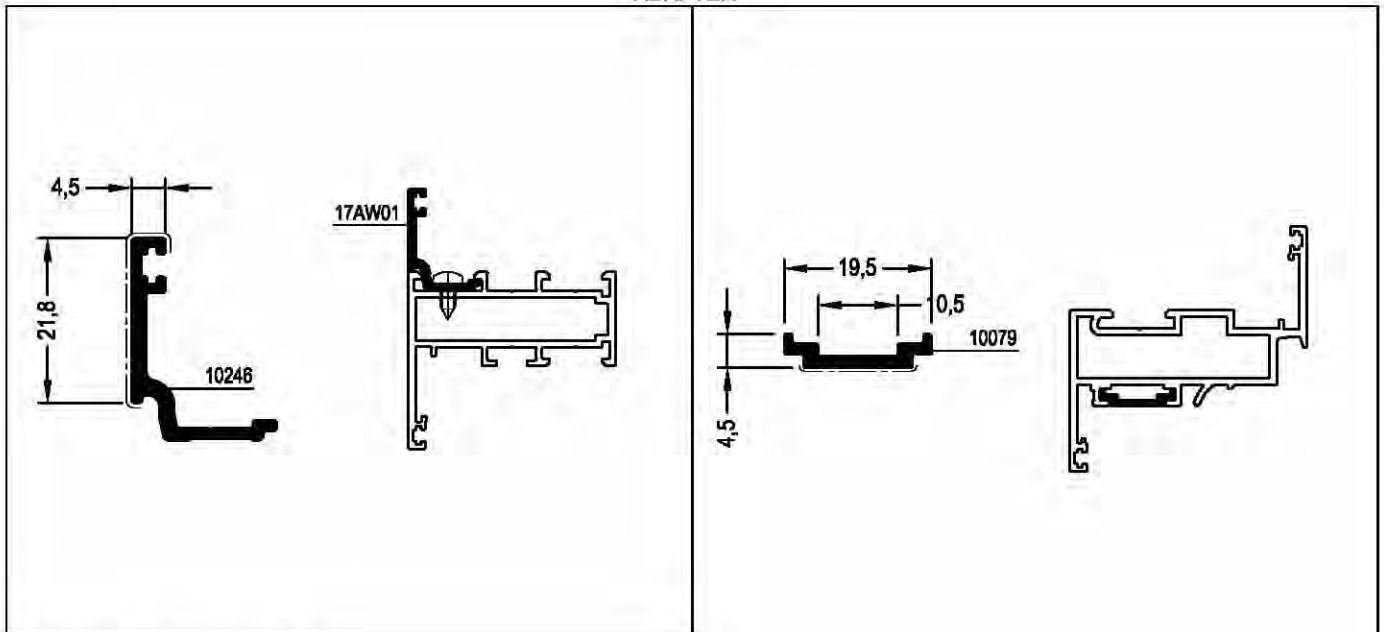

ADAPTER 4,5 / 21.8

PROFILE CODE	17AW01	THEORETICAL WEIGHT kg/mt	SLIDING ROAD PROFILE		
		0.234	PROFILE CODE	14IW01	THEORETICAL WEIGHT kg/mt
Coating Surface (cm)	Covering Surface (cm)		Coating Surface (cm)	5.198	0.105
10.426	3.014				

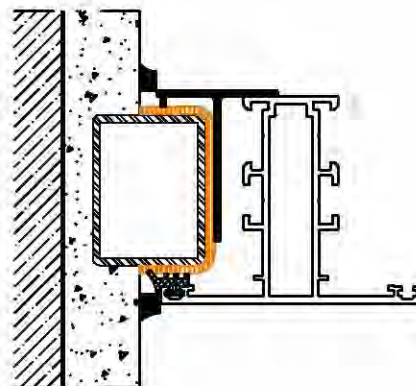
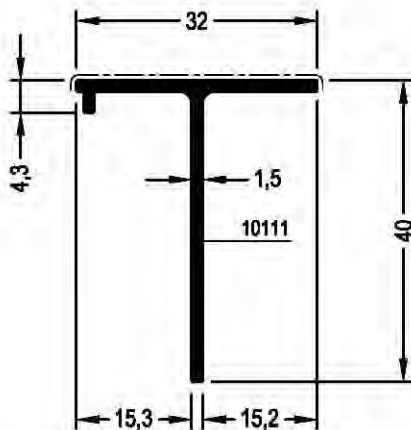

T PROFILE

PROFILE CODE	14PW03	THEORETICAL WEIGHT kg/mt
		0.300
Coating Surface (cm)	Covering Surface (cm)	
14.702	3.508	

ADAPTER

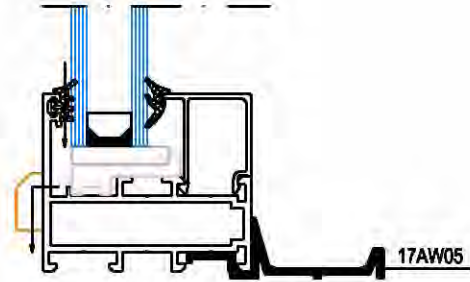
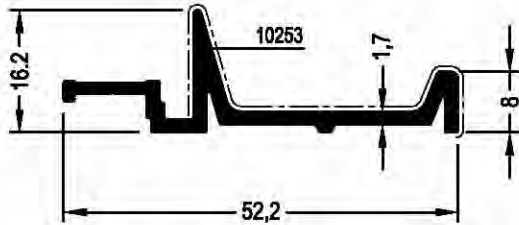

ADAPTER 52.2 / 16.2

PROFILE CODE	17AW05	THEORETICAL WEIGHT kg/mt
		0.407
Coating Surface (cm)	Covering Surface (cm)	
16.757	7.082	

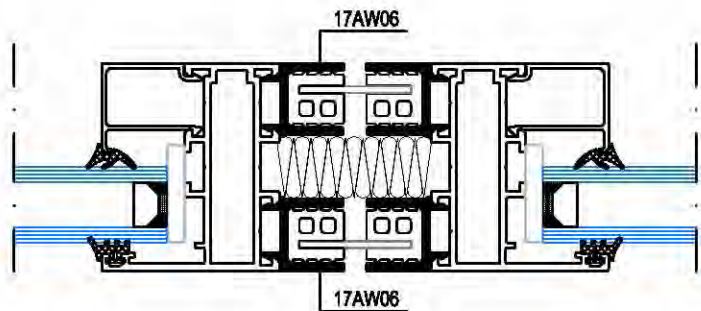
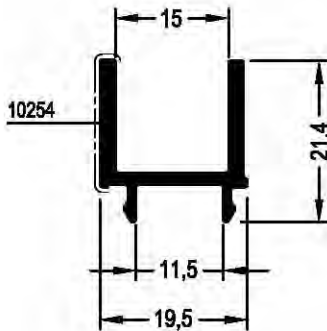

ADAPTER 19.5 / 21.4

PROFILE CODE	17AW06	THEORETICAL WEIGHT kg/mt
		0.278
Coating Surface (cm)	Covering Surface (cm)	
12.142	2.127	

ADAPTER

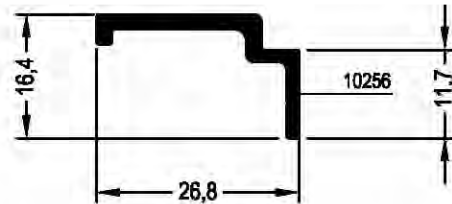
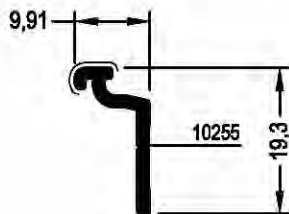

ADAPTER 9.91 / 19.3

ADAPTER 26.8 / 16.4

PROFILE CODE	17AW07	THEORETICAL WEIGHT kg/mt	PROFILE CODE	17AW08	THEORETICAL WEIGHT kg/mt
		0.113			0.221
Coating Surface (cm)	Covering Surface (cm)		Coating Surface (cm)	Covering Surface (cm)	
5.852	0.880		8.768	---	

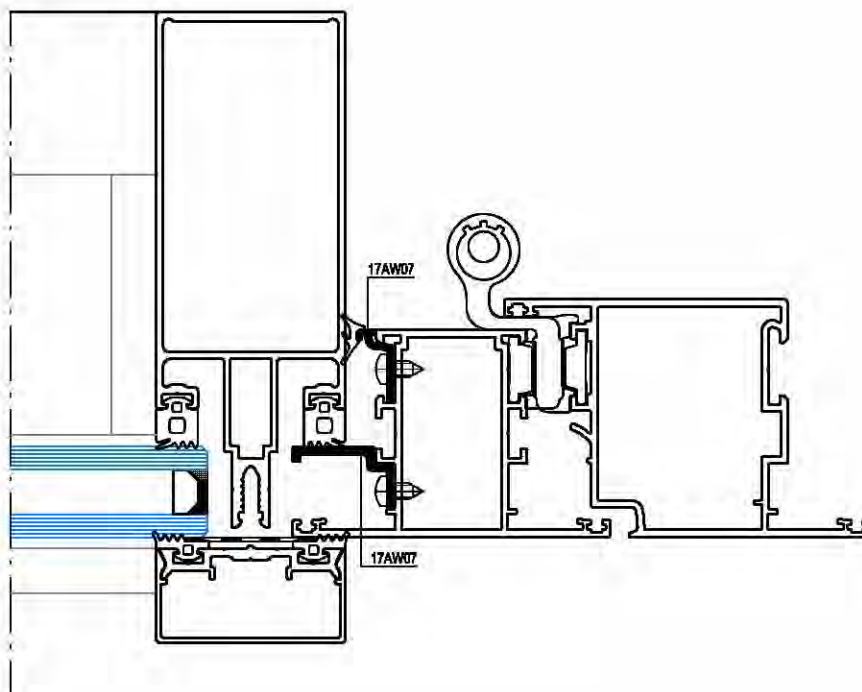

ADAPTER

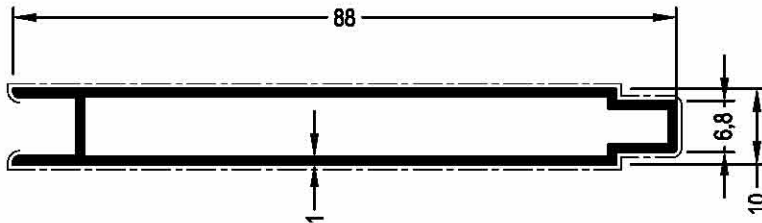

ADAPTER 10 / 88		
PROFILE CODE	1274	THEORETICAL WEIGHT kg/mt
		0.524
Coating Surface (cm)	Covering Surface (cm)	
21.159	16.536	

GLAZING BEAD

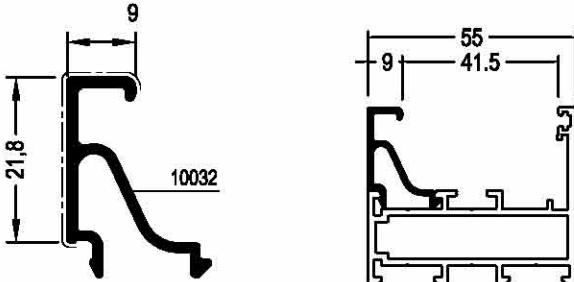
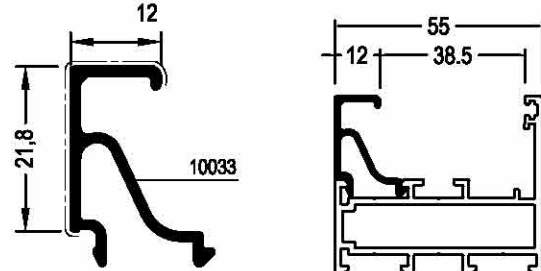
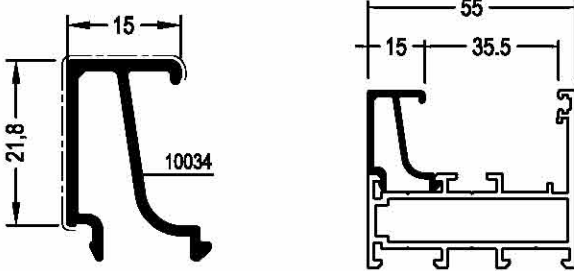
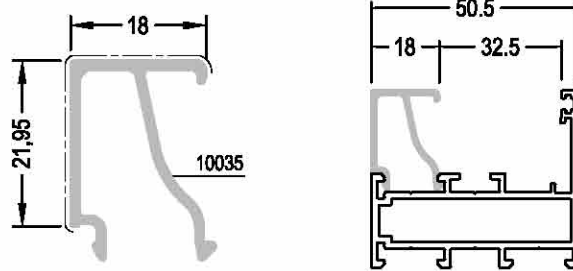
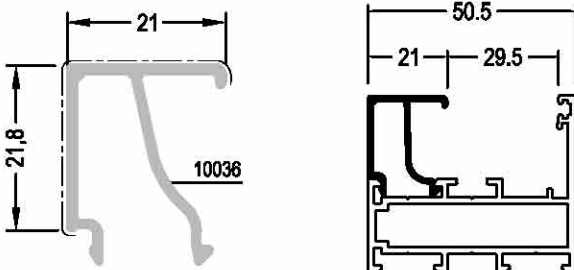
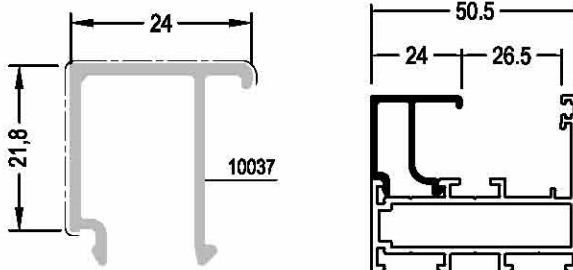
			
GLAZING BEAD 9 / 21.8		GLAZING BEAD 12 / 21.8	
PROFILE CODE	14GW01	THEORETICAL WEIGHT kg/mt	0.215
PROFILE CODE	14GW02	THEORETICAL WEIGHT kg/mt	0.226
Coating Surface (cm)	Covering Surface (cm)	Coating Surface (cm)	Covering Surface (cm)
13.130	3.459	13.712	3.759
			
GLAZING BEAD 15 / 21.8		GLAZING BEAD 18 / 21.95	
PROFILE CODE	14GW03	THEORETICAL WEIGHT kg/mt	0.245
PROFILE CODE	14GW04	THEORETICAL WEIGHT kg/mt	0.246
Coating Surface (cm)	Covering Surface (cm)	Coating Surface (cm)	Covering Surface (cm)
15.070	4.059	15.074	4.226
			
GLAZING BEAD 21 / 21.8		GLAZING BEAD 24 / 21.8	
PROFILE CODE	14GW05	THEORETICAL WEIGHT kg/mt	0.256
PROFILE CODE	14GW06	THEORETICAL WEIGHT kg/mt	0.260
Coating Surface (cm)	Covering Surface (cm)	Coating Surface (cm)	Covering Surface (cm)
16.031	4.569	16.706	4.959

GLAZING BEAD

GLAZING BEAD 27 / 21.95		GLAZING BEAD 28.5 / 21.95	
PROFILE CODE	14GW07	THEORETICAL WEIGHT kg/mt	0.270
Coating Surface (cm)	Covering Surface (cm)	PROFILE CODE	14GW19
16.474	5.126	THEORETICAL WEIGHT kg/mt	0.276
GLAZING BEAD 33 / 21.8		GLAZING BEAD 36 / 21.95	
PROFILE CODE	14GW09	THEORETICAL WEIGHT kg/mt	0.291
Coating Surface (cm)	Covering Surface (cm)	PROFILE CODE	14GW10
17.712	5.830	THEORETICAL WEIGHT kg/mt	0.311
GLAZING BEAD 39 / 21.95			
PROFILE CODE	14GW11	THEORETICAL WEIGHT kg/mt	0.321
Coating Surface (cm)	Covering Surface (cm)		
19.535	6.326		

CORNER CLEATS

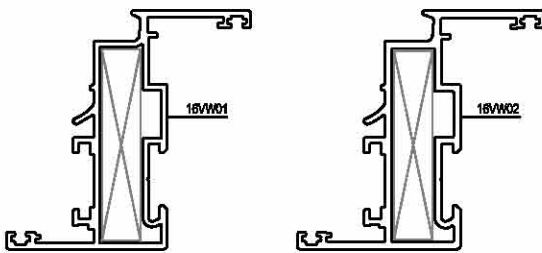
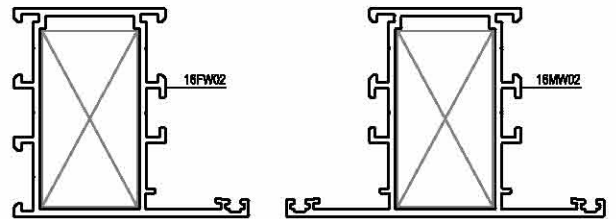
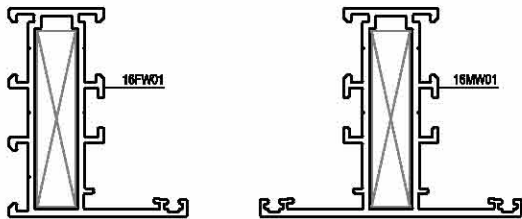
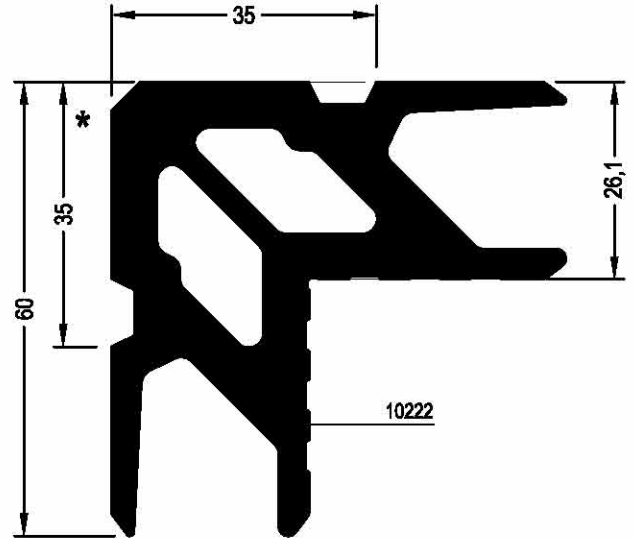
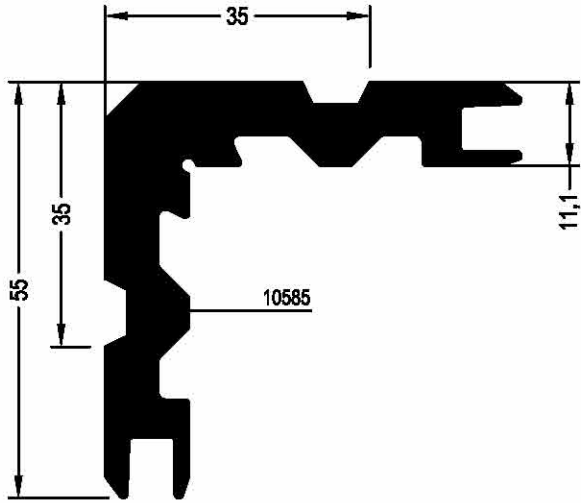

* pressed profile

* pressed profile

CORNER CLEATS 11.1 / 55				CORNER CLEATS 26.1 / 60			
PROFILE CODE	14LW14	PRES	THEORETICAL WEIGHT kg/mt 2.154	PROFILE CODE	14LW32	PRES	THEORETICAL WEIGHT kg/mt 3.363
APPLICATION PROFILE	PROFILE CODE 16FW01, 16MW01 16VW01, 16VW02			APPLICATION PROFILE	PROFILE CODE 16FW02, 16MW02		

CORNER CLEATS

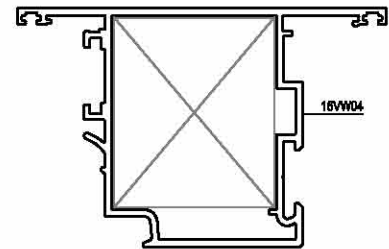
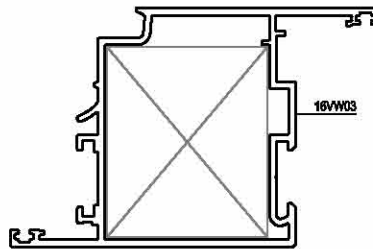
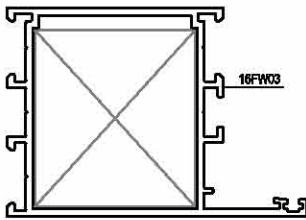
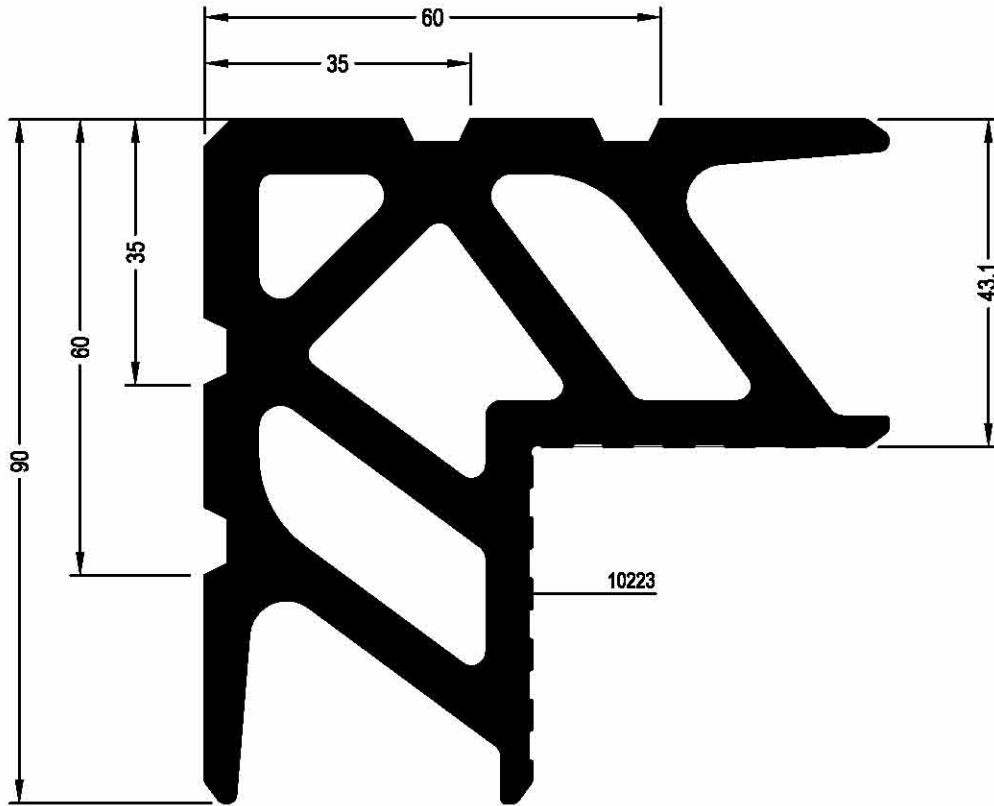

CORNER CLEATS		43.1 / 90	
PROFILE CODE	14LW33	PRES	THEORETICAL WEIGHT kg/mt 7.344
APPLICATION PROFILE	PROFILE CODE		
	16FW03 16VW03, 16VW04		

T JUNCTION

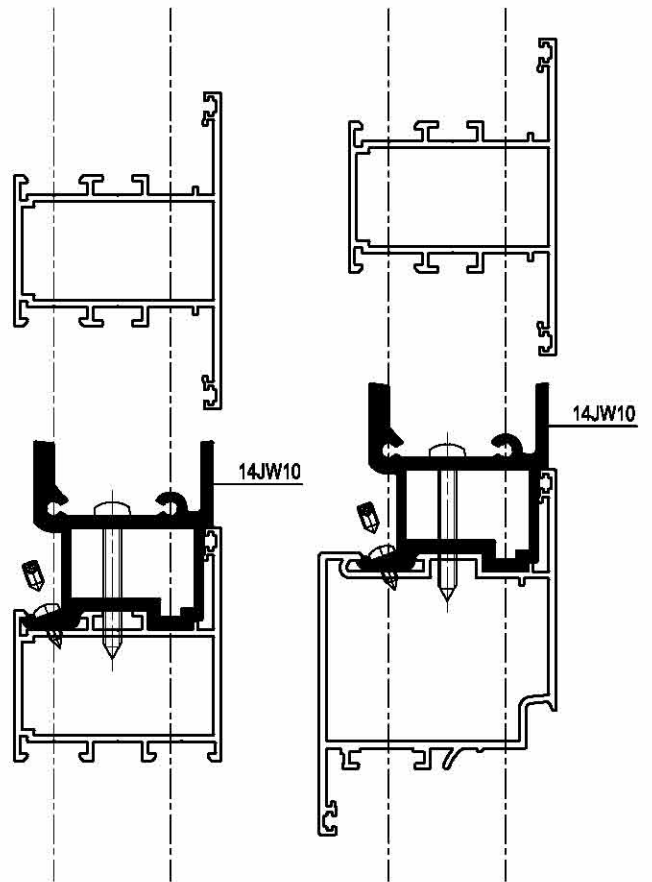
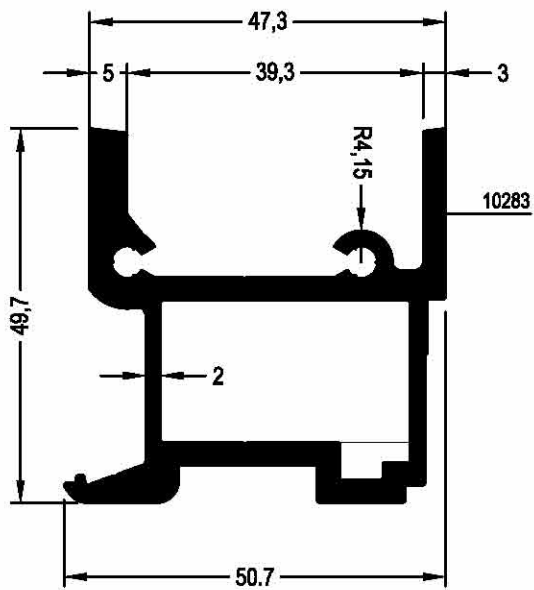

T JUNCTION 50.7 / 49.7

PROFILE CODE

14JW10

PRES

THEORETICAL WEIGHT kg/m

1.643

T JUNCTION

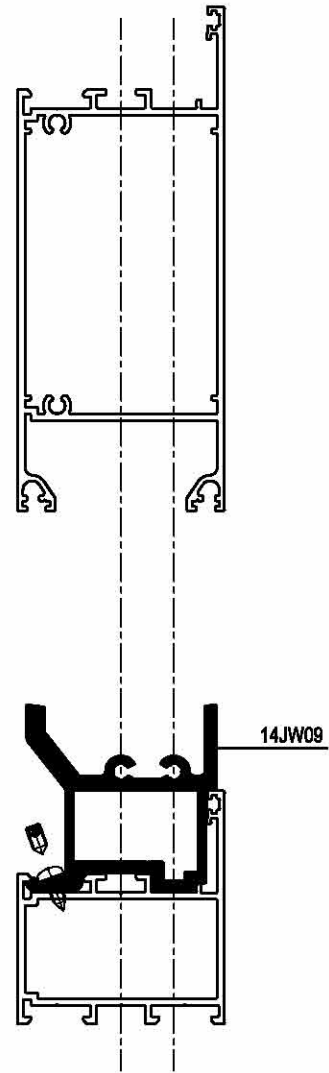
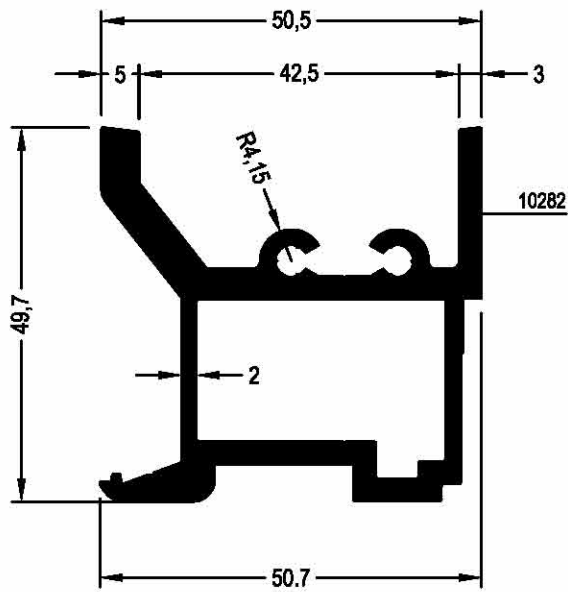

T JUNCTION		50.7 / 49.7	
PROFILE CODE	14JW09	PRES	THEORETICAL WEIGHT kg/m
			1.692

c - ACCESSORIES

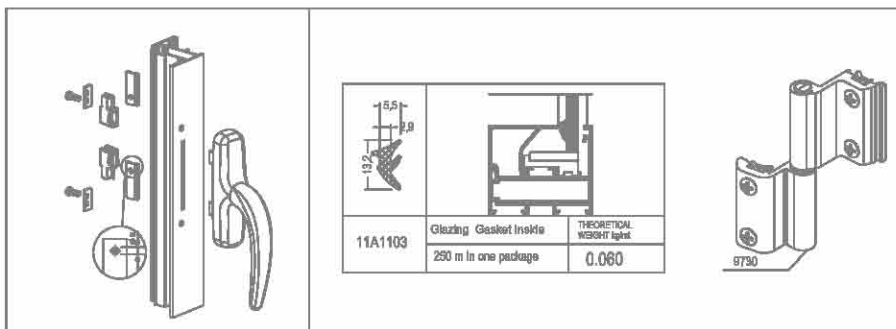

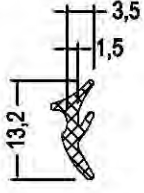
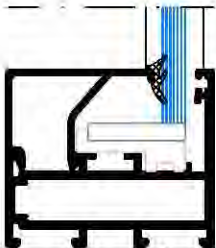
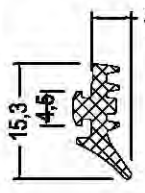
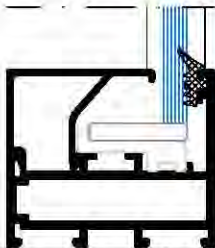
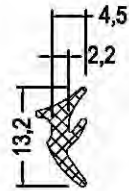
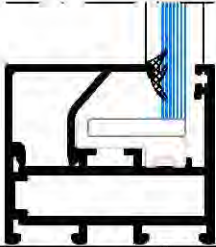
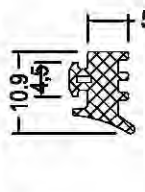
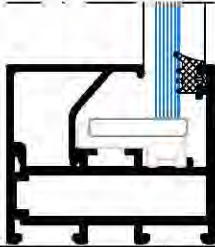
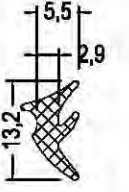
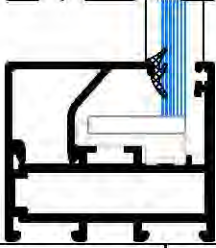
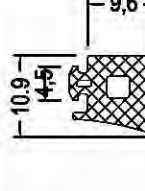
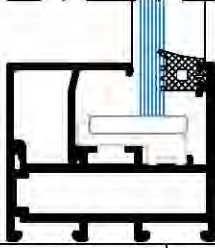

E.P.D.M. GASKETS

					
11A1101	Glazing Gasket Inside	THEORETICAL WEIGHT kg/mt	11A2701	Glazing Gasket Outside	THEORETICAL WEIGHT kg/mt
	300 m in one package	0.050 kg/mt		270 m in one package	0.055 kg/mt
MATERIALS	E.P.D.M.		MATERIALS	E.P.D.M.	
					
11A1102	Glazing Gasket Inside	THEORETICAL WEIGHT kg/mt	11A2702	Glazing Gasket Outside	THEORETICAL WEIGHT kg/mt
	250 m in one package	0.060 kg/mt		217 m in one package	0.069
MATERIALS	E.P.D.M.		MATERIALS	E.P.D.M.	
					
11A1103	Glazing Gasket Inside	THEORETICAL WEIGHT kg/mt	11A2703	Glazing Gasket Outside	THEORETICAL WEIGHT kg/mt
	215 m in one package	0.070 kg/mt		138 m in one package	0.108
MATERIALS	E.P.D.M.		MATERIALS	E.P.D.M.	

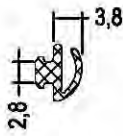
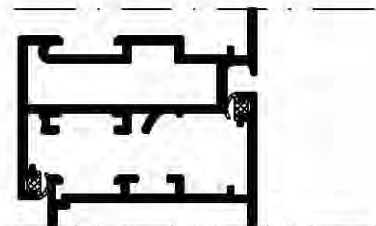
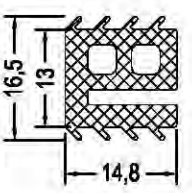
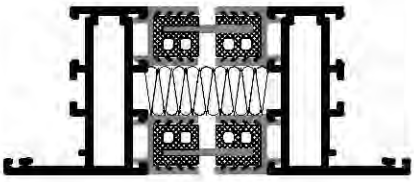
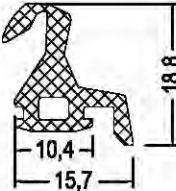
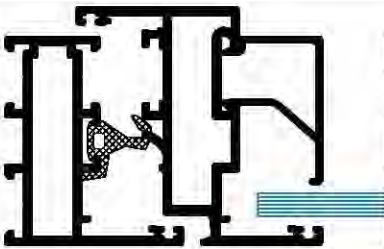
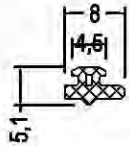
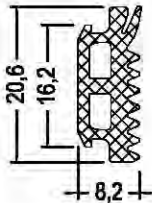
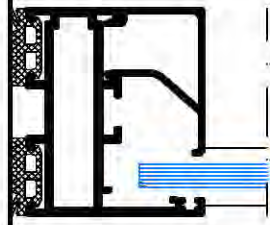
E.P.D.M. GASKETS

					
<p>11A1301</p>	<p>Acoustical Gasket 375 m in one package</p>	<p>THEORETICAL WEIGHT kg/mt 0.040 kg/mt</p>	<p>11A1706 Gaskets for Adapter Profile 73 mt in one package</p>	<p>THEORETICAL WEIGHT gr/mt 0.200 kg/mt</p>	
<p>MATERIALS</p>	<p>E.P.D.M.</p>		<p>MATERIALS</p>	<p>E.P.D.M.</p>	
					
<p>11A1405</p>	<p>Central Gasket 93 m in one package</p>	<p>THEORETICAL WEIGHT kg/mt 0.160 kg/mt</p>	<p>11A1502 Gaskets for Adapter Profile 517 mt in one package</p>	<p>THEORETICAL WEIGHT gr/mt 0.029 kg/mt</p>	
<p>MATERIALS</p>	<p>E.P.D.M.</p>		<p>MATERIALS</p>	<p>E.P.D.M.</p>	
					
			<p>11A1503</p>	<p>Gaskets for Adapter Profile 128 m in one package</p>	<p>THEORETICAL WEIGHT kg/mt 0.155</p>
			<p>MATERIALS</p>	<p>E.P.D.M.</p>	

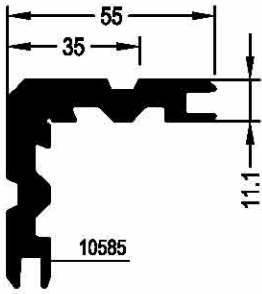
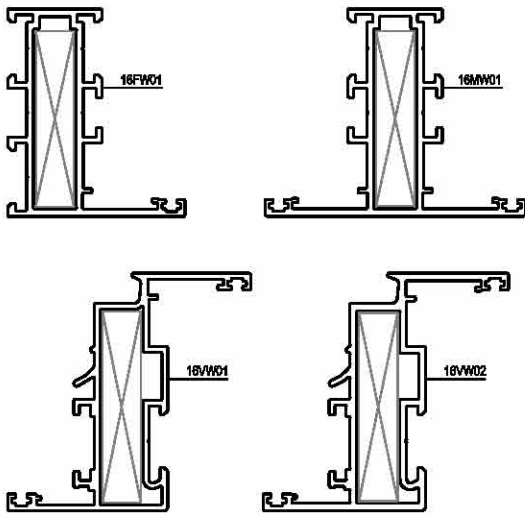

CORNER CLEATS

DRAWING / INFORMATION				APPLICATION	
 <p>* pressed profile</p>					
CORNER CLEATS WITH PRES 11.1 / 55					
PROFILE CODE	14LW14	PRES	THEORETICAL WEIGHT kg/mt		
			2.154		
APPLICATION PROFILES	Cutting Sizes (mm)	PIECE CODE NUMBER			
16FW01	10284	47.4 mm	---		
16VW01	10287	51.5 mm	---		
16VW02	10288	50.7 mm	---		
16MW01	10291	47.4 mm	---		

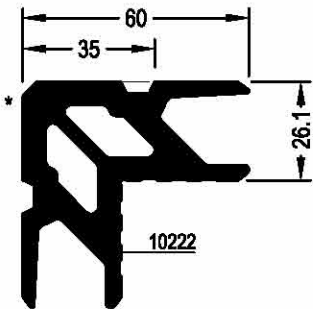
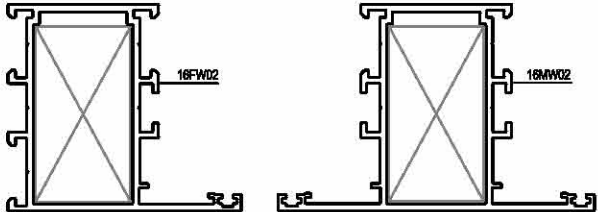
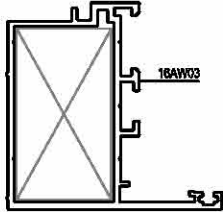
CORNER CLEATS

DRAWING / INFORMATION				APPLICATION	
 <p>* pressed profile</p>					
CORNER CLEATS WITH PRES 26.1 / 60					
PROFILE CODE	14LW32	PRES	THEORETICAL WEIGHT kg/mt		
			3.363		
APPLICATION PROFILES		Cutting Sizes (mm)	PIECE CODE NUMBER		
16FW02	10285	47.4 mm	----		
16MW02	10292	47.4 mm	----		
16AW03	10294	46.4 mm	----		

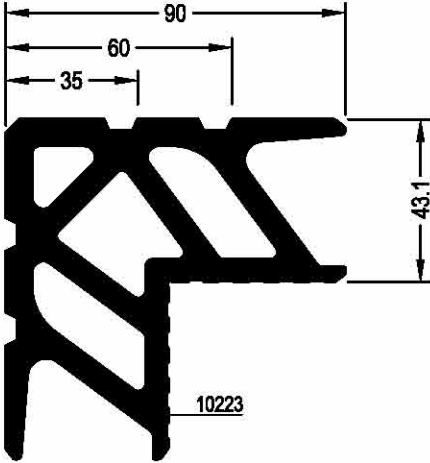
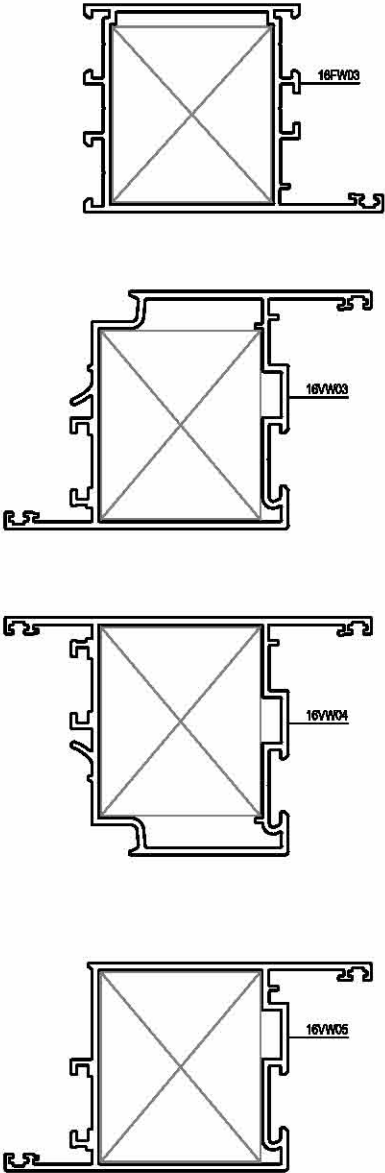
CORNER CLEATS

DRAWING / INFORMATION				APPLICATION			
 <p>* pressed profile</p>							
CORNER CLEATS WITH PRES 43.1 / 90							
PROFILE CODE	14LW33	PRES	THEORETICAL WEIGHT kg/mt				
			7.344				
APPLICATION PROFILES		Cutting Sizes (mm)	PIECE CODE NUMBER				
16FW03	10286	47.4 mm	----				
16VW03	10289	50.9 mm	----				
16VW04	10290	50.9 mm	----				
16VW05			----				

CORNER CLEATS

DRAWING / INFORMATION

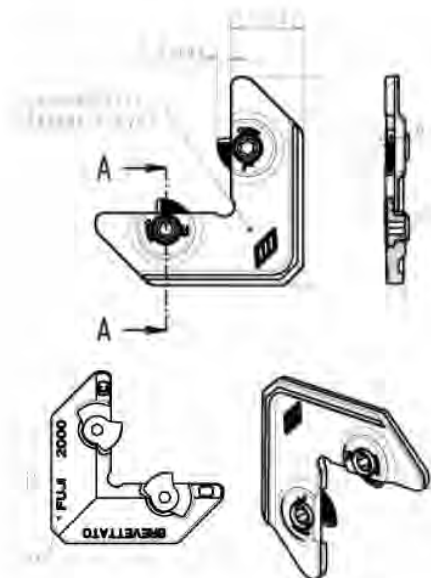

APPLICATION

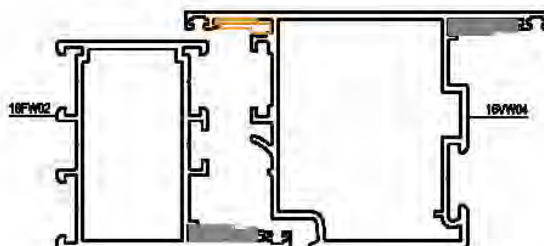
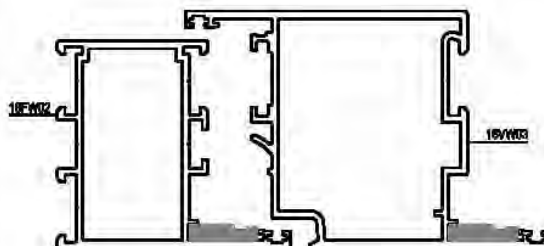
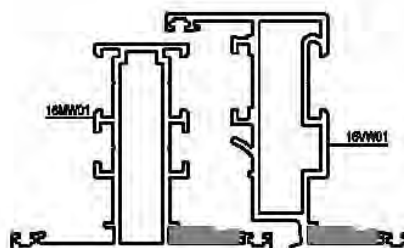
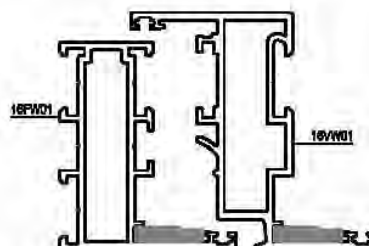

CODE FUJI 2000 Aluminium Corner Joint with nut

APPLICATION PROFILES	16FW01, 16FW02, 16FW03
	16VW01, 16VW02, 16VW03, 16VW04, 16VW05
	16MW01, 16MW02
MATERIALS	Die -Cast Corner Joint

CORNER CLEATS

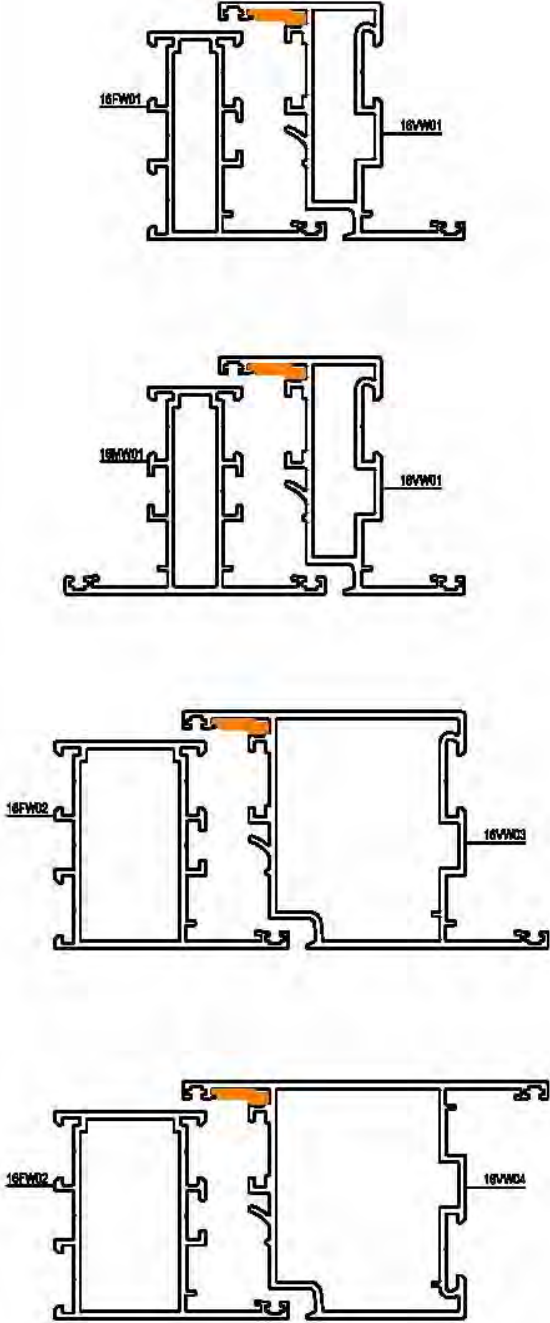
DRAWING / INFORMATION	APPLICATION
	
<p>CODE MO20</p>	<p>Plastic Corner Joint</p>
<p>APPLICATION PROFILES</p>	<p>16VW01,16VW02,16VW03,16VW04,16VW05</p>
<p>MATERIALS</p>	<p>Black nylon</p>

T JUNCTION

DRAWING / INFORMATION				APPLICATION			
* pressed profile				* pressed profile			
T JUNCTION 50.7 / 49.7				T JUNCTION 50.7 / 49.7			
PROFILE CODE	14JW10	PRES	THEORETICAL WEIGHT kg/mt 1.056	PROFILE CODE	14JW09	PRES	THEORETICAL WEIGHT kg/mt 1.692
APPLICATION PROFILES		Cutting Sizes (mm)	PIECE CODE NUMBER	APPLICATION PROFILES		Cutting Sizes (mm)	PIECE CODE NUMBER
16MW01	10291	10.9 mm	---	16KW02	10295	69.2 mm	---
16MW02	10292	25.9 mm	---				

HINGES

DRAWING / INFORMATION

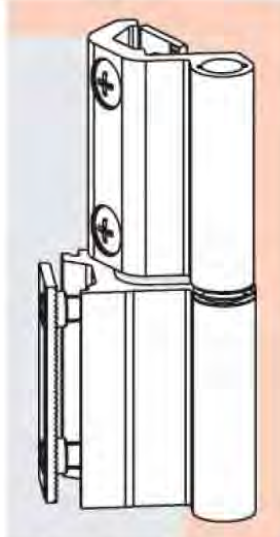

APPLICATION

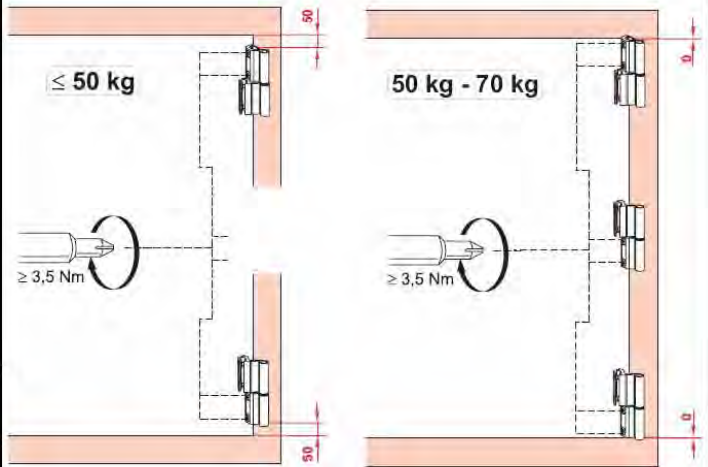

CODE 14A1701 Window Hinge

COLOURS White (RAL 9016), Black (RAL 9005)

MATERIALS Anodized silver
Black nylon bush, Hinges in extruded aluminium
Galvanized steel pin
Galvanized die cast zinc alloy

CAPACITIES 2 hinges : 50 kg
3 hinges : 70 kg

ROTO FRANK

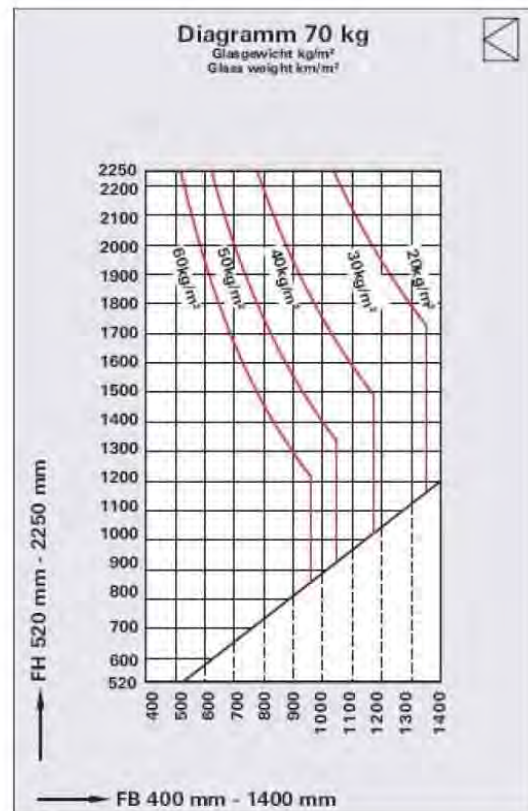
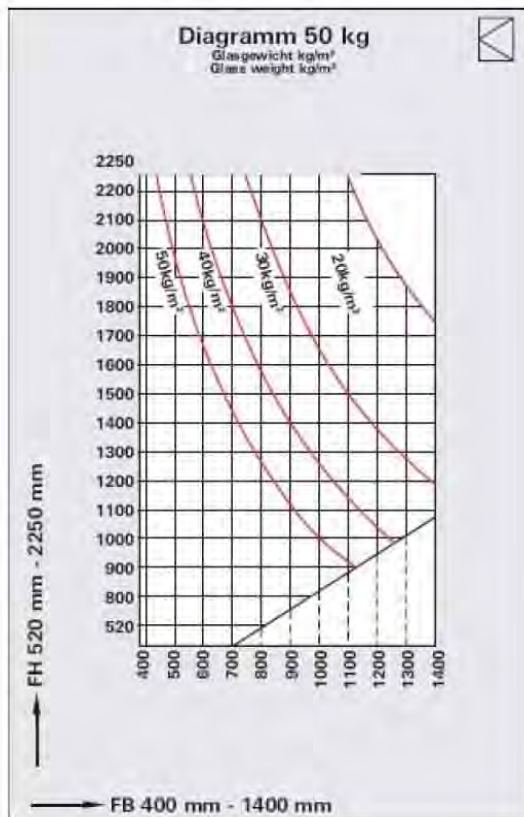

HINGES

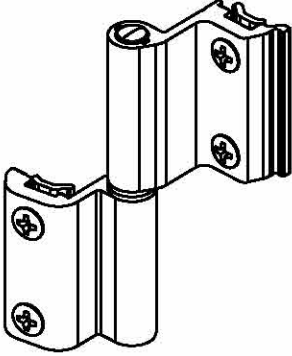
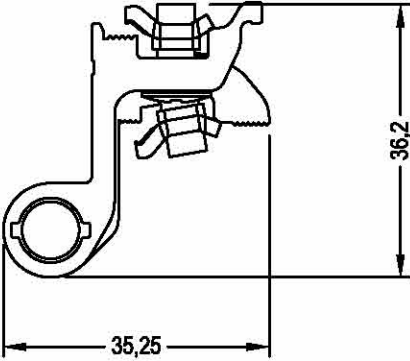
DRAWING / INFORMATION		APPLICATION	
			
CODE	9730		Window Hinge
COLOURS	White (RAL 9016), Black (RAL 9005)		
MATERIALS	Hinges in extruded aluminium		
	Black nylon bush		
	Galvanized steel pin		
CAPACITIES	Galvanized die cast zinc alloy		
	2 hinges : 80 kg		
		3 hinges : 90 kg	

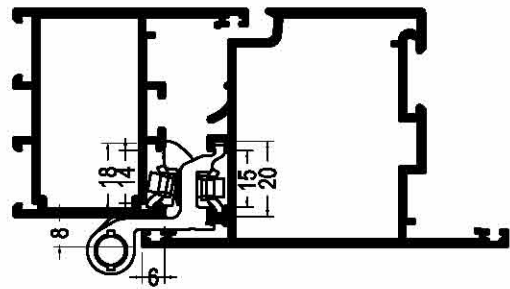
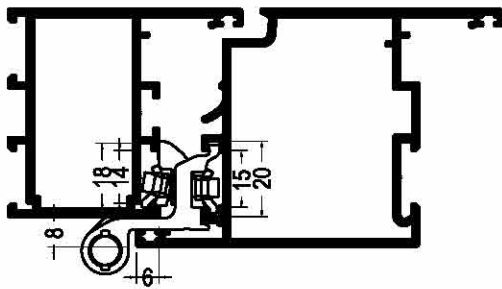
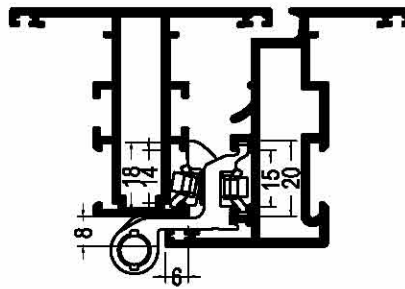
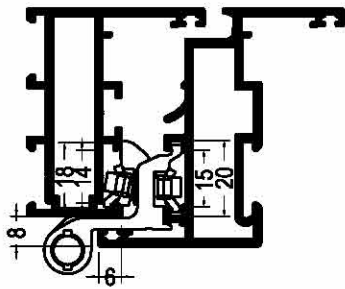

HINGES

DRAWING / INFORMATION

APPLICATION

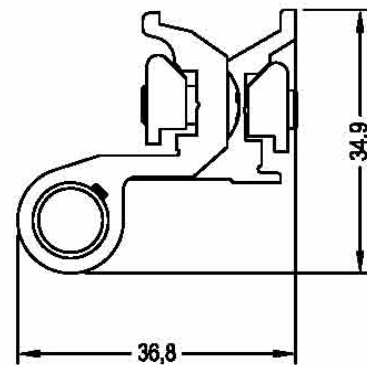
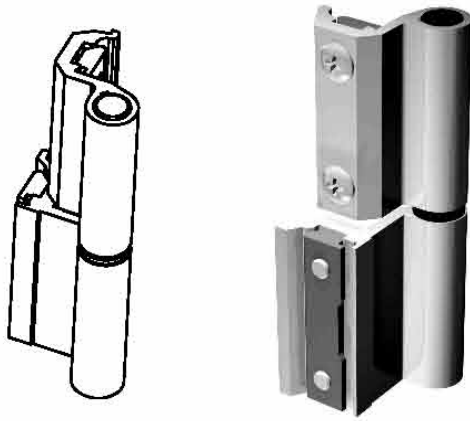

CODE	M10 PR	Window Hinge
------	--------	--------------

COLOURS	White (RAL 9016) , Black (RAL 9005)
	Electrostatic painted in RAL colours
	Anodized silver and bronze
MATERIALS	Hinges in extruded aluminium , 48 mm length
	Black nylon bush
	Galvanized steel pin
	Galvanized die cast zinc alloy , 46.5 mm length
CAPACITIES	2 hinges : 80 kg
	3 hinges : 90 kg

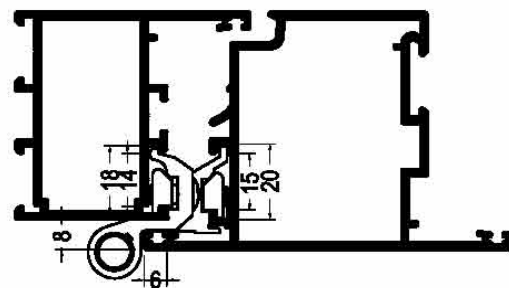
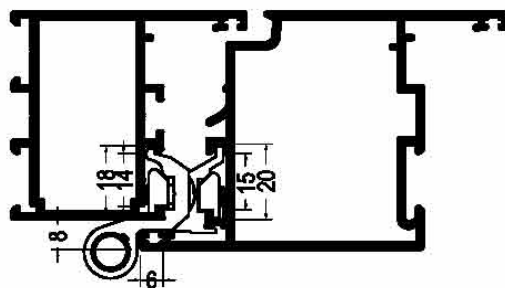
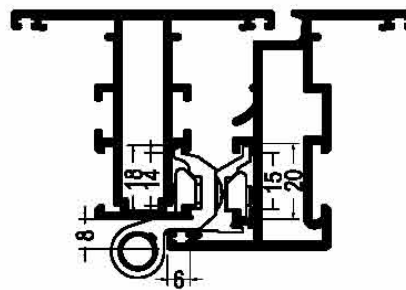
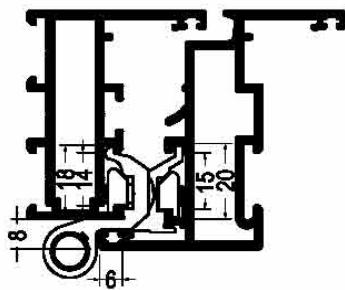

HINGES

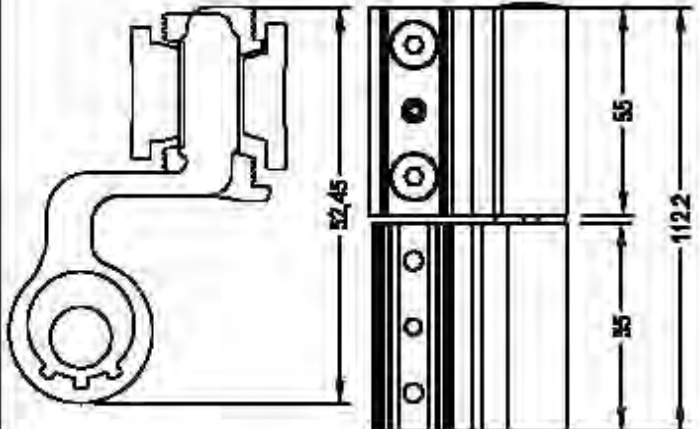
DRAWING / INFORMATION	APPLICATION
	
<p>CODE 5603 Window Hinge</p>	
<p>COLOURS</p>	<p>White (RAL 9016), Black (RAL 9005)</p>
<p>MATERIALS</p>	<p>Hinges in extruded aluminium</p>
	<p>Black nylon bush</p>
	<p>Galvanized steel pin</p>
	<p>Galvanized die cast zinc alloy</p>

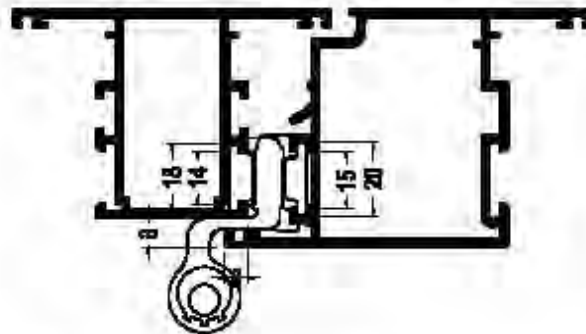
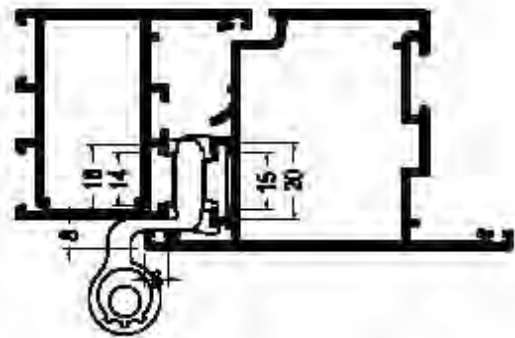
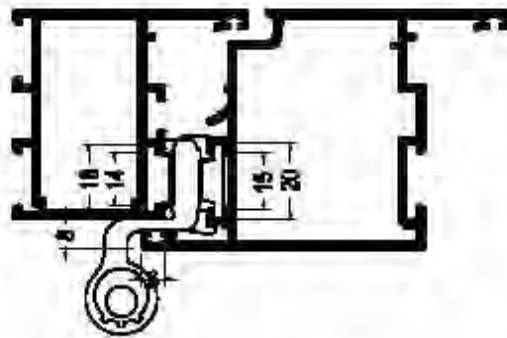

VASISTAS

DRAWING / INFORMATION

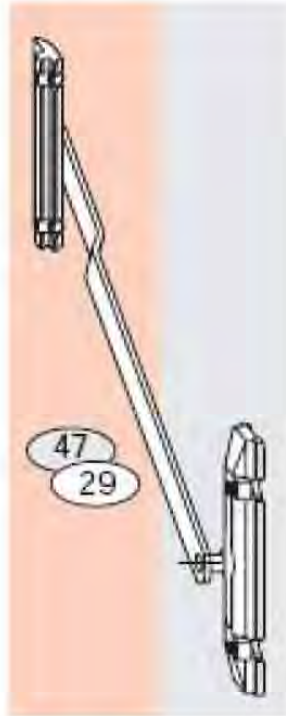

APPLICATION

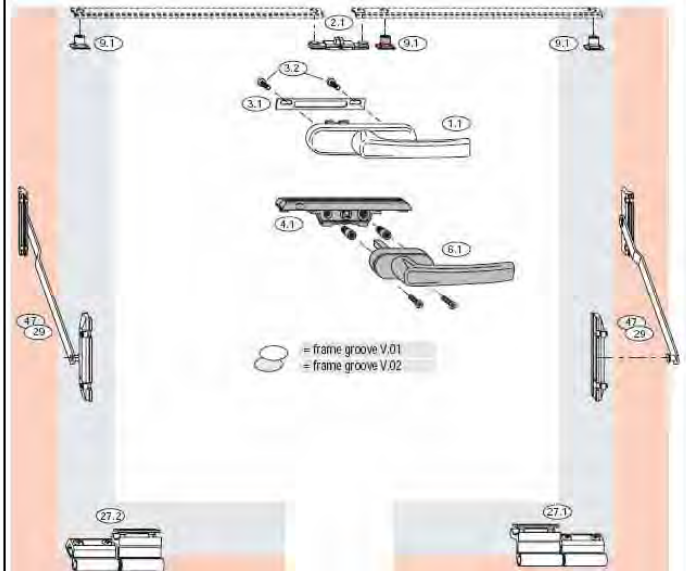

ROTO FRANK

CODE 14A1501 Vasistas



70kg



Limitation of sash formats

S.W. - Sash width 400mm - 1400mm
 S.H. - Sash height 350mm - 1200mm
 S.kg.max - Max. sash weight 70kg

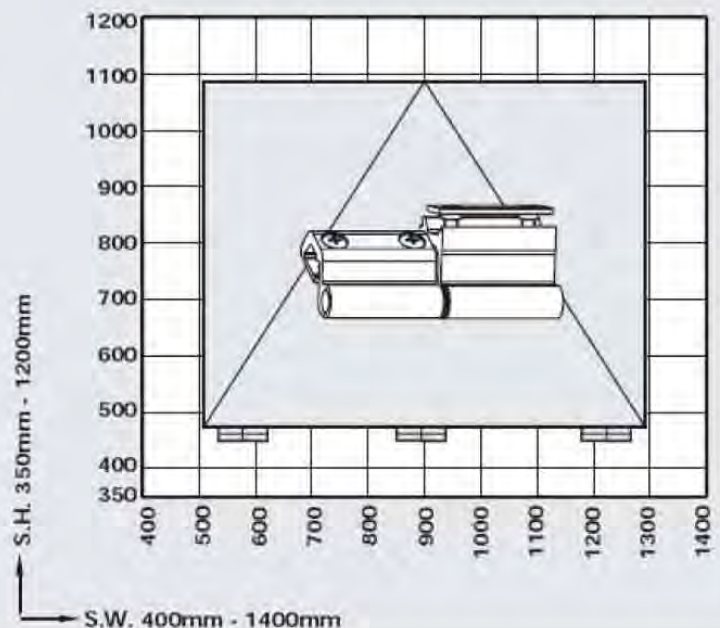

The information in the application diagram refers to the glass weight in kg/m².

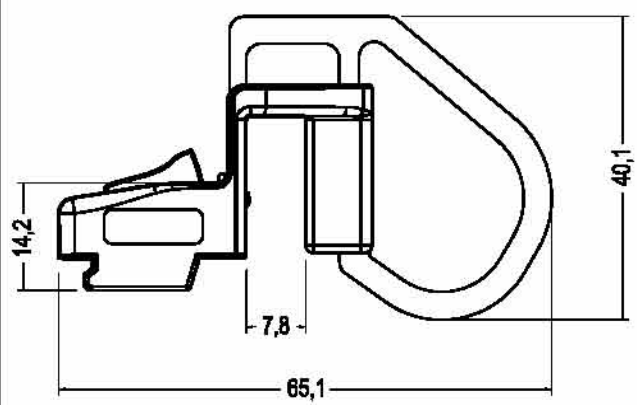
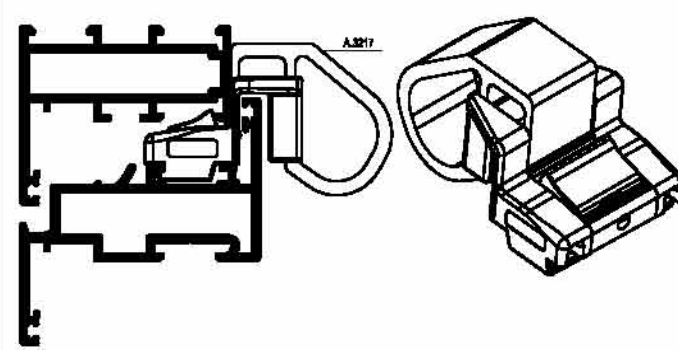

VASISTAS

DRAWING / INFORMATION		APPLICATION
		
CODE	A.3217	Vasistas Spring
COLOURS	White (RAL 9016) , Black (RAL 9005)	
		
CODE	03209	Vasistas Spring
COLOURS	Black	
MATERIALS	Black nylon	

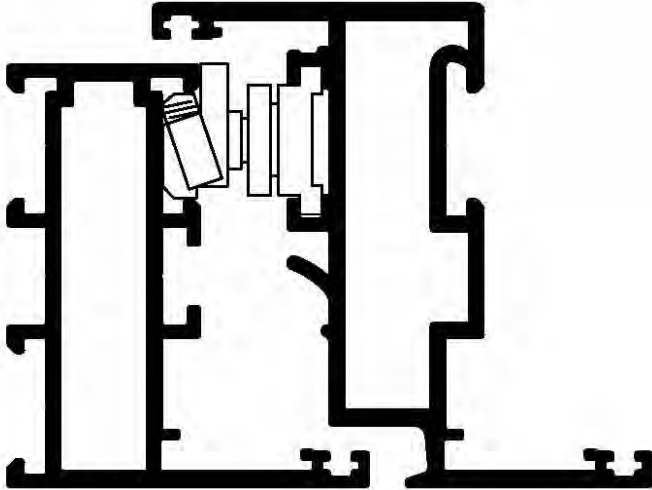
VASISTAS

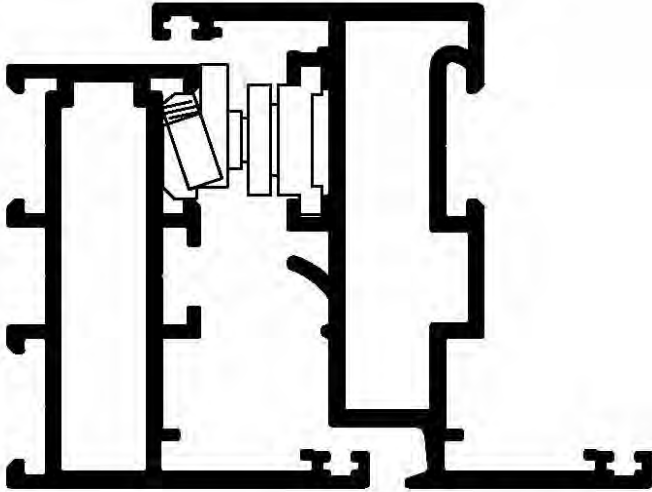
DRAWING / INFORMATION		APPLICATION	
			
CODE	3207		Vasistas
COLOURS	Natural , Anodized silver and bronze		
	Electrostatic painted in RAL colours		
MATERIALS	Extruded aluminium , 209 mm length		
	Black nylon bush		
	Galvanized steel pin		
CAPACITIES	2 hinges : 60 kg		
	3 hinges : 70 kg		
			
CODE	ERT1861		Vasistas
COLOURS	Natural , Anodized silver and bronze		
	Electrostatic painted in RAL colours		

LOCKING KIT

DRAWING / INFORMATION

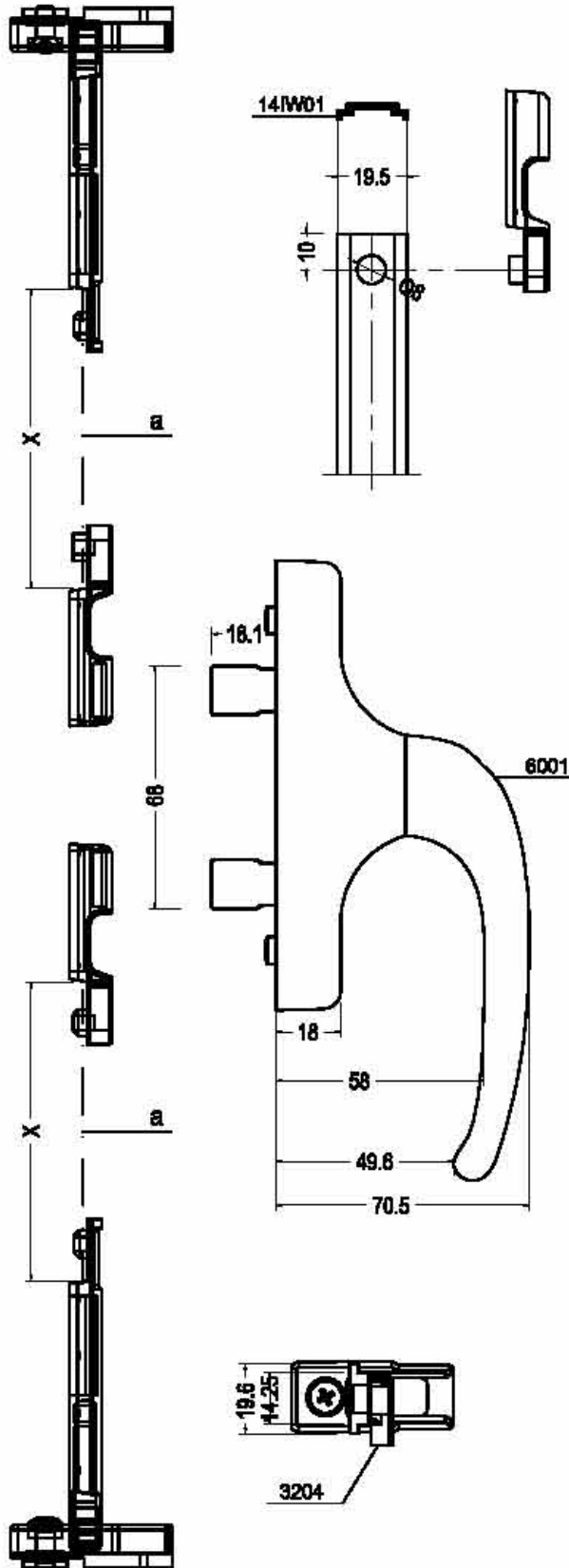

APPLICATION

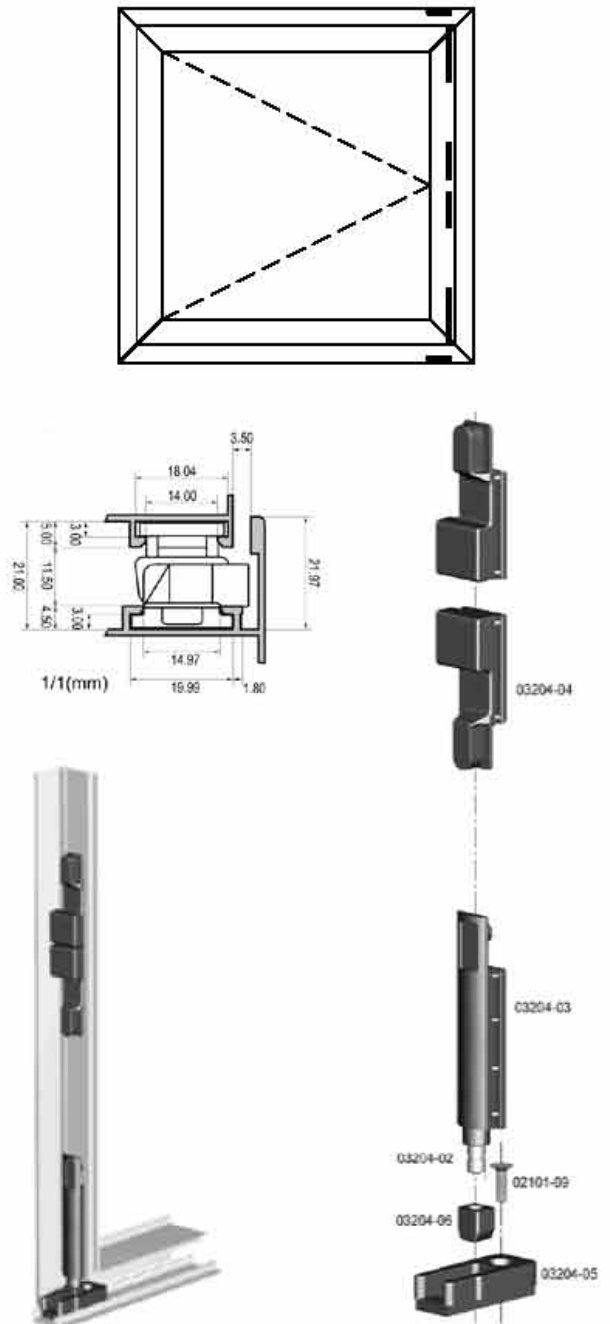

CODE	03204	Locking Kit
COLOURS	Black nylon and galvanized coated	
	Galvanized die-cast zinc alloy	
MATERIALS	Black nylon bush	
	Galvanized steel pin	

TURN WINDOWS MECHANISM

DRAWING

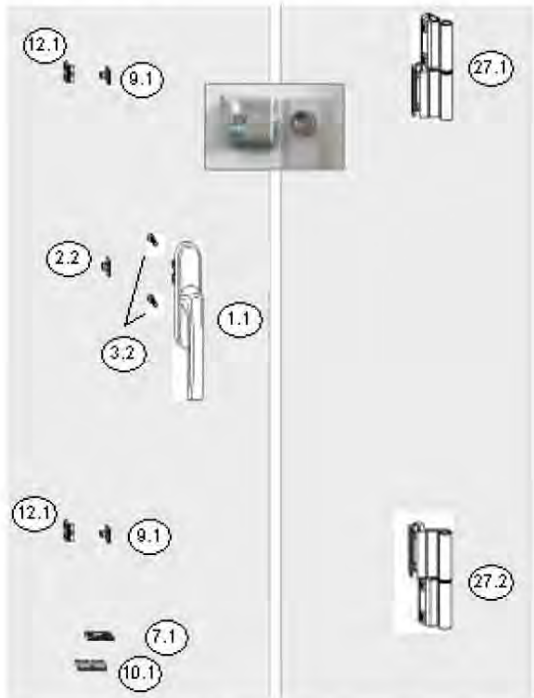

APPLICATION

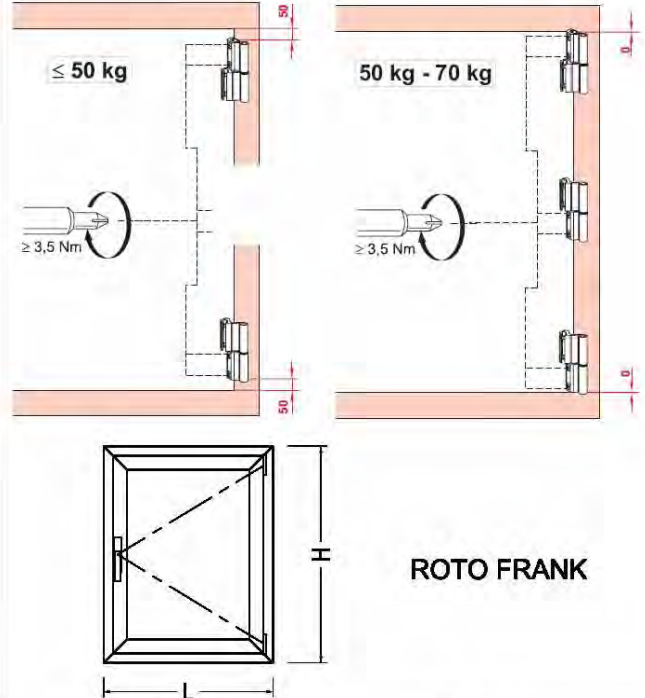

CODE	14A1701	Turn Windows Mechanism
Width L (mm)	Height H (mm)	Weight (kg)
400 mm - 1400 mm	520 mm - 2250 mm	50-70 Kg / m ²

CONTENTS	Hinges	2 set.
	Handle	1 set.
	Locking Group	1 set.

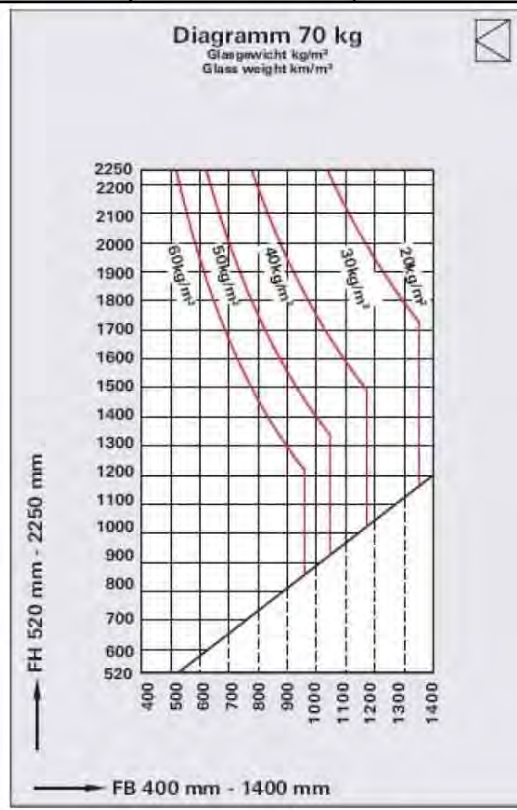
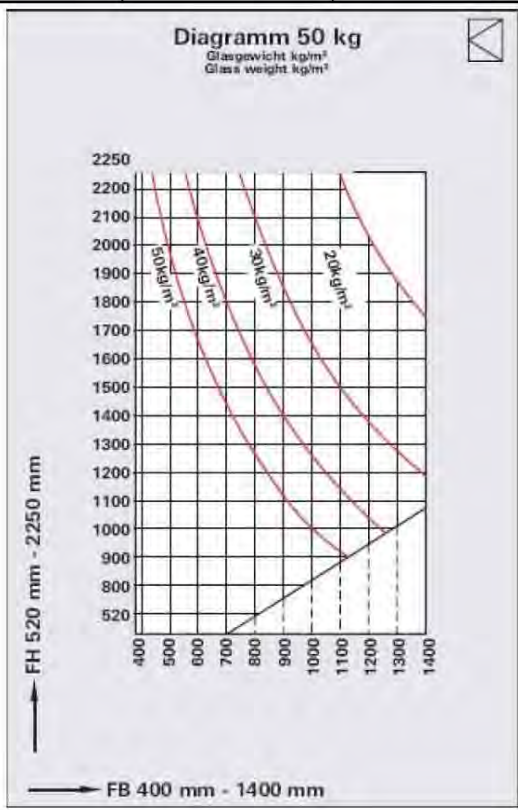

TURN AND TILT MECHANISM

DRAWING

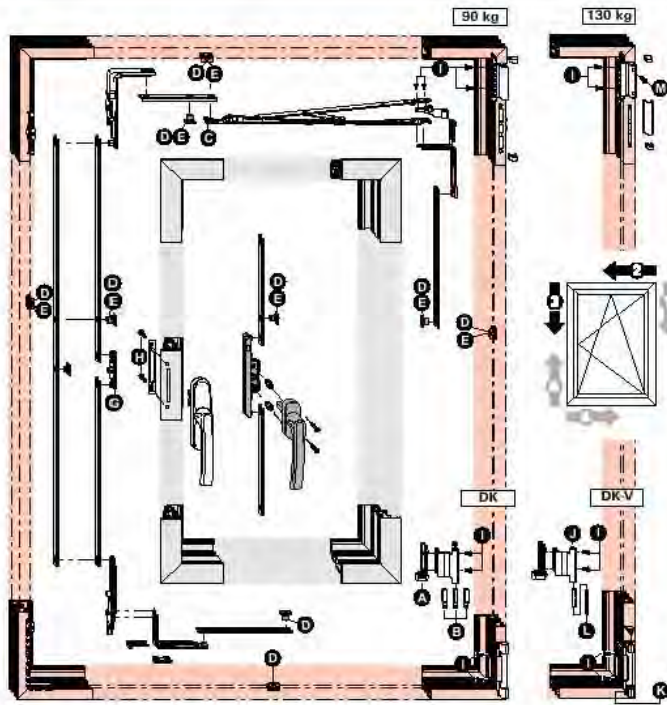

APPLICATION

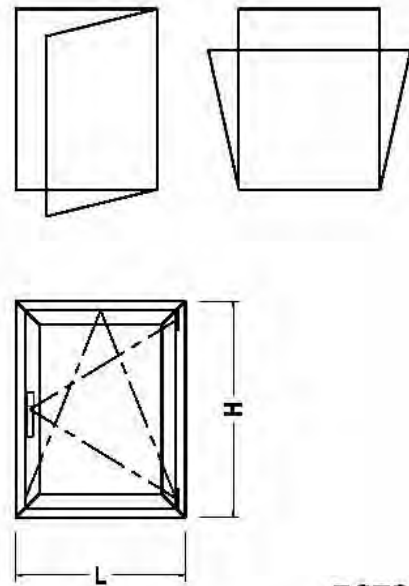

ROTO FRANK

CODE 14A1301 Turn and Tilt Mechanism

CODE 14A1302 Turn and Tilt Mechanism

Width L (mm)	Height H (mm)	Weight (kg)
405 mm - 1600 mm	520 mm - 2400 mm	90 Kg.

Width L (mm)	Height H (mm)	Weight (kg)
405 mm - 1600 mm	520 mm - 2400 mm	130 Kg.

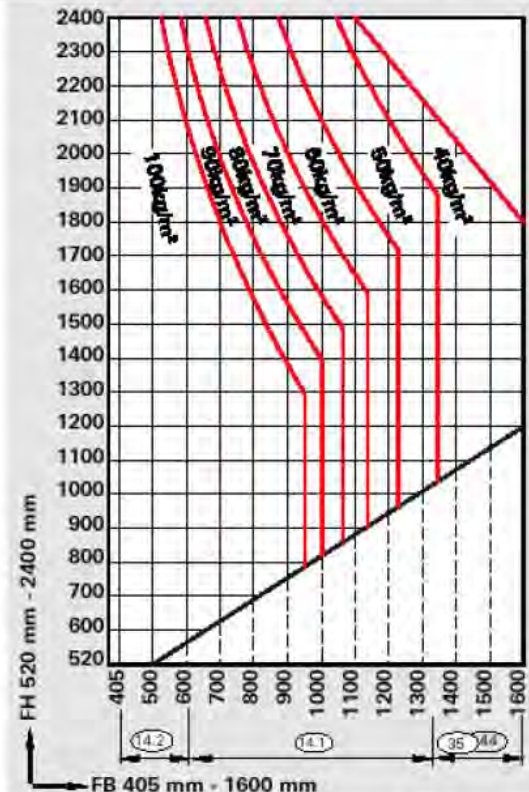
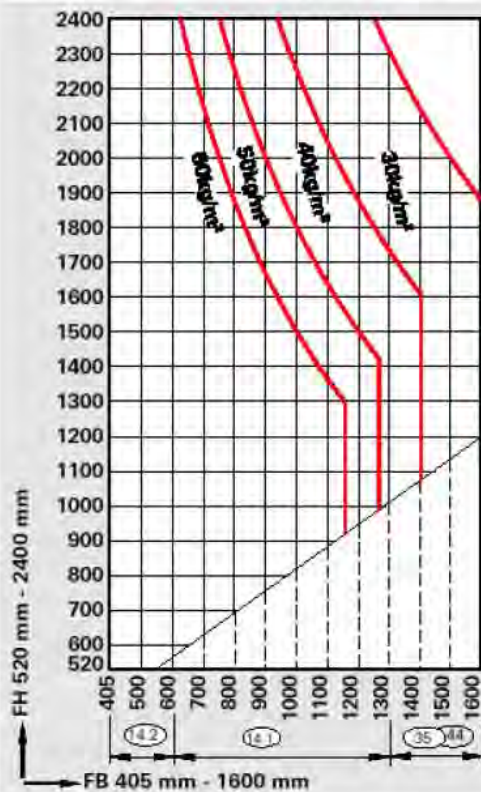

DRAWING / INFORMATION



APPLICATION



CODE **MO 22.02** **Window Bolt**

CODE **MO 22.01** **Window Bolt**

HANDLES

DRAWING / INFORMATION		APPLICATION	
 <p style="text-align: right;">ROTO FRANK</p>		 <p style="text-align: right;">ROTO FRANK</p>	
CODE	14A1101	Window Handle	
CODE	14A1102	Window Handle	
COLOURS	White (RAL 9018)	COLOURS	White (RAL 9018)
	Black (RAL 9005)		Black (RAL 9005)
	Anodized silver		Anodized silver
MATERIALS	Die-cast aluminium alloy	MATERIALS	Die-cast aluminium alloy
	Die-cast zinc alloy		Die-cast zinc alloy
	Black nylon		Black nylon

HANDLES

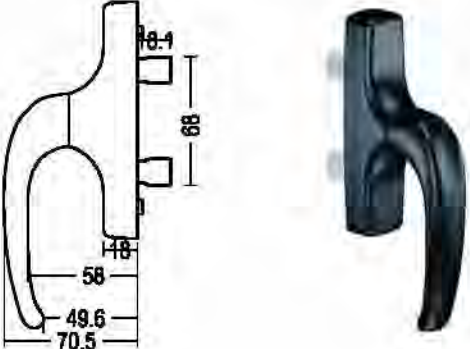
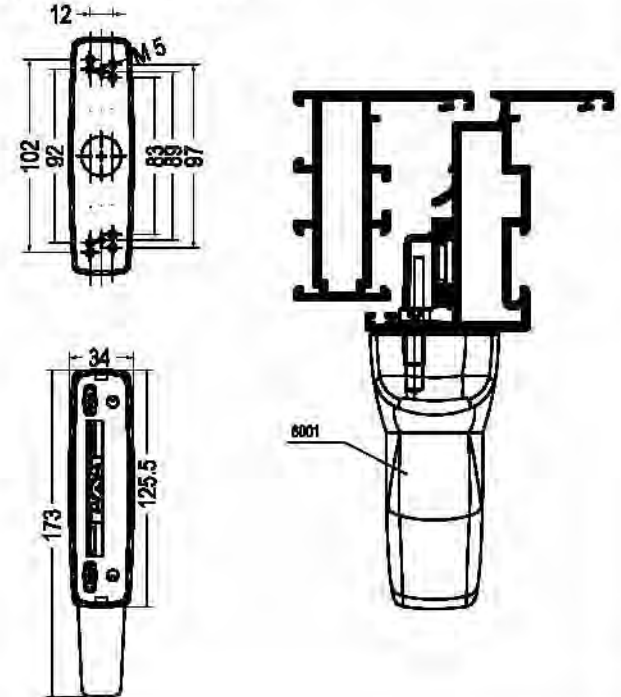
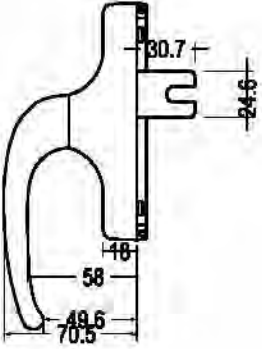
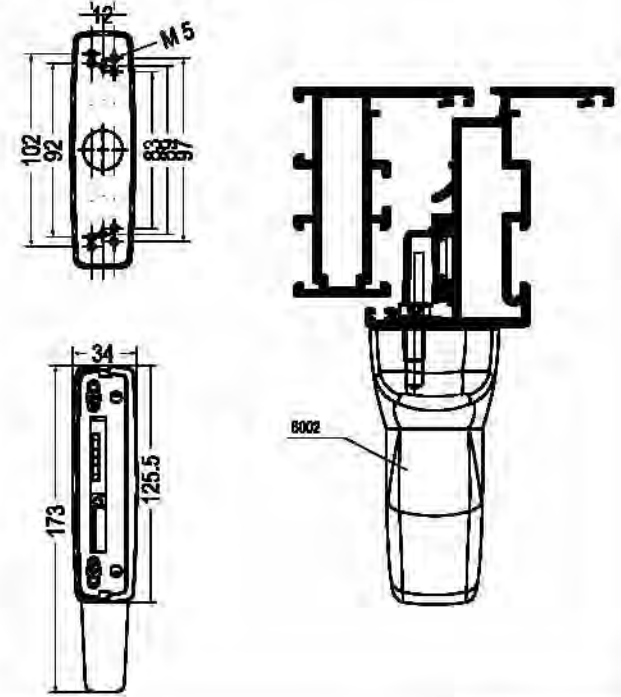
DRAWING / INFORMATION		APPLICATION
		<p>connection dimensions</p> 
CODE	6001	Window Handle
COLOURS	White (RAL 9016)	
	Black (RAL 9005)	
	Electrostatic painted in RAL colours	
MATERIALS	Die-cast aluminium alloy	
	Die-cast zinc alloy	
	Black nylon	
		<p>connection dimensions</p> 
CODE	6002	Window Handle
COLOURS	White (RAL 9016)	
	Black (RAL 9005)	
	Electrostatic painted in RAL colours	
MATERIALS	Die-cast aluminium alloy	
	Die-cast zinc alloy	
	Black nylon	

HANDLES

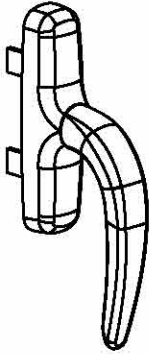
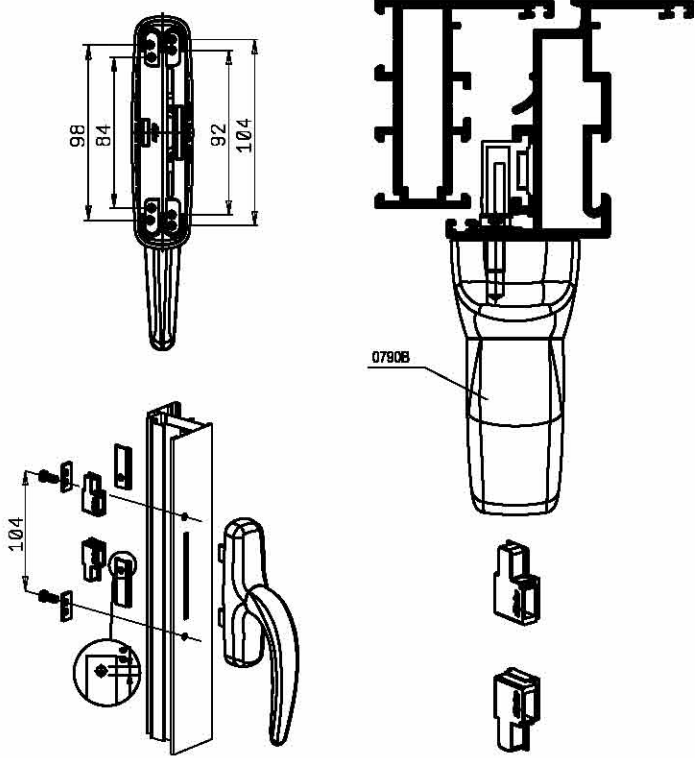
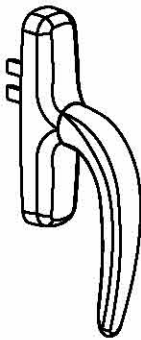
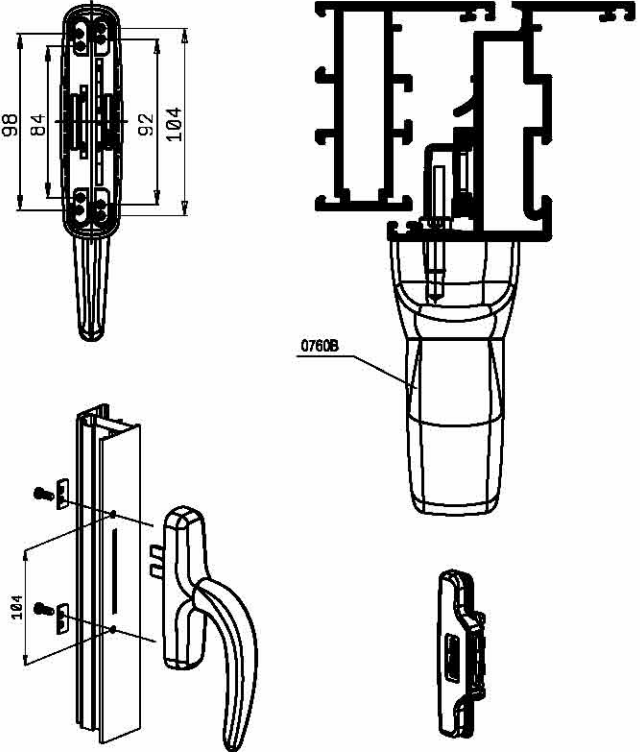
DRAWING / INFORMATION		APPLICATION
		
CODE	0790B	Window Handle
COLOURS	White (RAL 9016)	
	Black (RAL 9005)	
MATERIALS	Die-cast aluminium alloy	
	Die-cast zinc alloy	
	Black nylon	
		
CODE	0760B	Window Handle
COLOURS	White (RAL 9016)	
	Black (RAL 9005)	
MATERIALS	Die-cast aluminium alloy	
	Die-cast zinc alloy	
	Black nylon	

DOOR HANDLES

DRAWING / INFORMATION		APPLICATION	
			
CODE	X402	Door Handle	
CODE	AK23	Door Handle	
COLOURS	White (RAL 9016) Black (RAL 9005)	COLOURS	White (RAL 9016) , Black (RAL 9005) Electrostatic painted in RAL colours , Anodized silver
			
CODE	X103	Door Handle	
CODE	AK20	Door Handle	
COLOURS	White (RAL 9016) Black (RAL 9005)	COLOURS	White (RAL 9016) , Black (RAL 9005) Electrostatic painted in RAL colours , Anodized silver
			
CODE	DH605	Door Handle	
CODE	AK21	Door Handle	
COLOURS	White (RAL 9016) Black (RAL 9005)	COLOURS	White (RAL 9016) , Black (RAL 9005) Electrostatic painted in RAL colours , Anodized silver

COVERS

DRAWING / INFORMATION

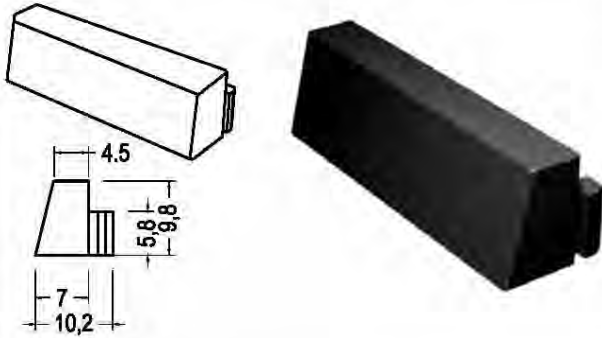

CODE 08000-03 Drainage Cover

COLOURS Black , White

MATERIALS Black nylon

APPLICATION

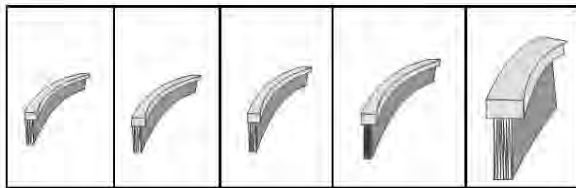
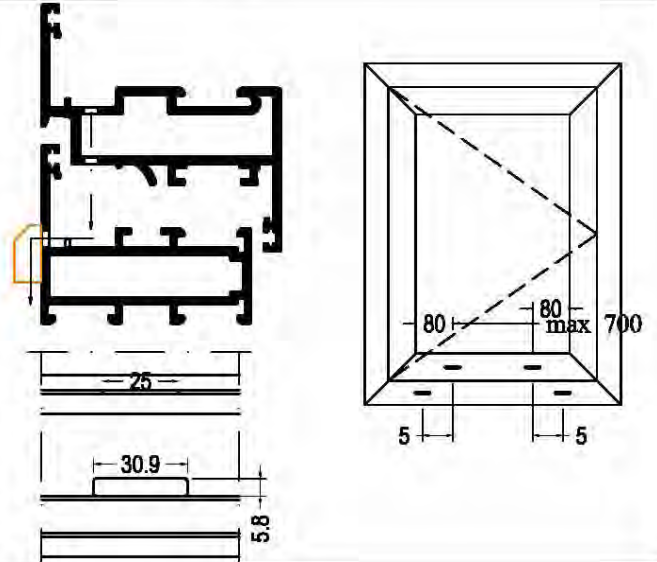

PB - 6 PB - 7 PB - 8 PB - 10 PB - 13

CODE Brush

COLOURS Grey

MATERIALS Black nylon

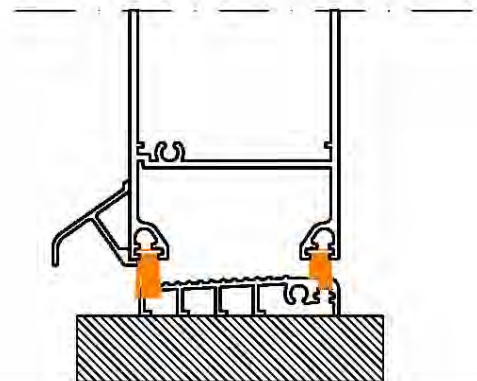

CODE TOP BOTTOM Face Cup

APPLICATION PROFILES

COLOURS Black - White

MATERIALS Black nylon

WEDGES

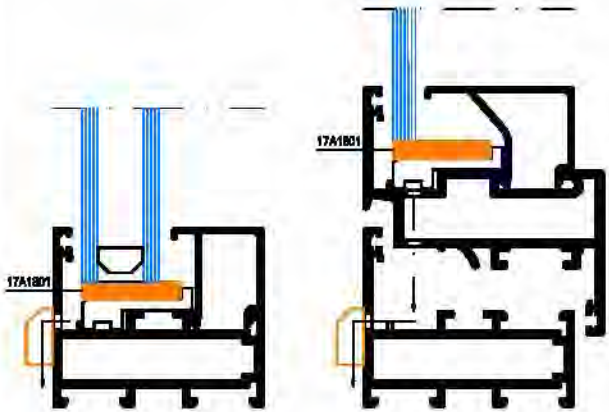
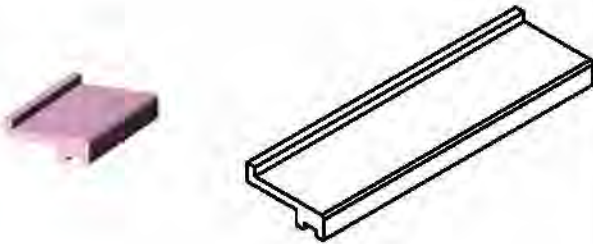
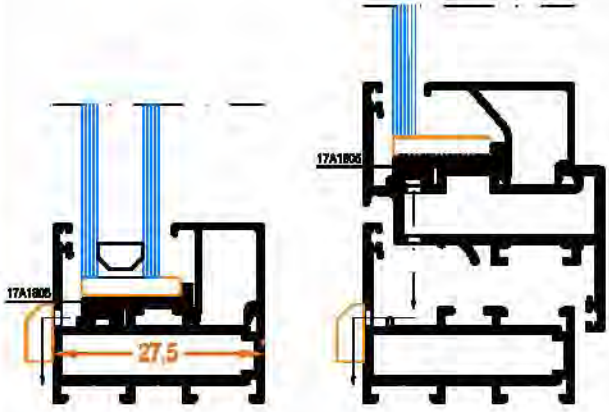
DRAWING / INFORMATION		APPLICATION	
			
CODE	17A1801		Wedges
DIMENSIONS	5 mm X 30 mm X 100 mm		
COLOURS	Black		
MATERIALS	Polyamide		
			
CODE	17A1805		Wedges (frame + vent)
DIMENSIONS	8 mm X 28.75 mm X 100 mm		
COLOURS	Black		
MATERIALS	Polyamide		

MORTISE LOCKS

DRAWING / INFORMATION

APPLICATION

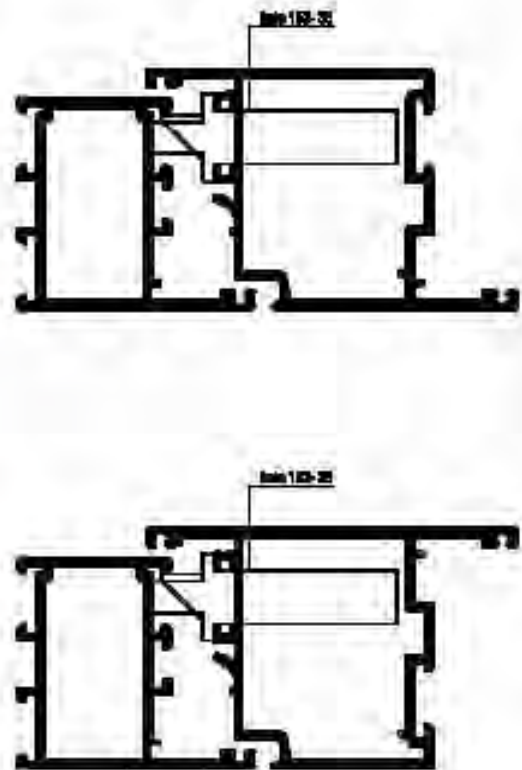
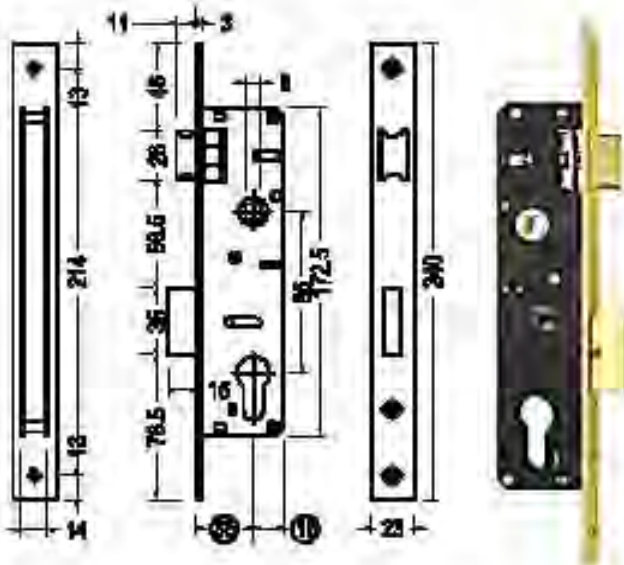

TYPE	B
163.35	36

CODE	153.35	Mortise Lock
CYLINDER	DOMUS 16089K	
UNIT WEIGHT	690 gr	
MATERIALS	Case : Steel , Electrostatic black powder painted	
	Deadbolt : Zinc alloy	
	Linch : MS 58 Brass	

MORTISE LOCKS

DRAWING / INFORMATION

APPLICATION

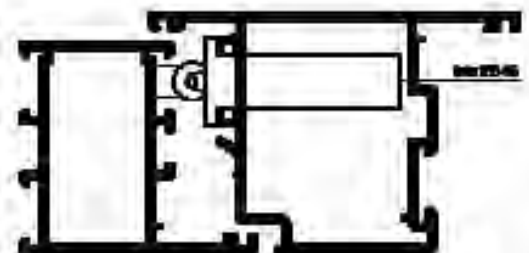
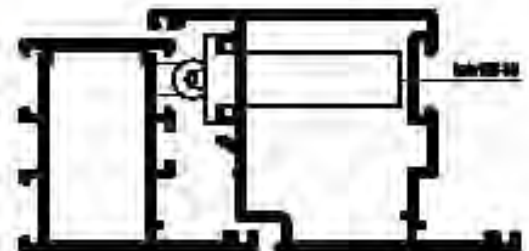
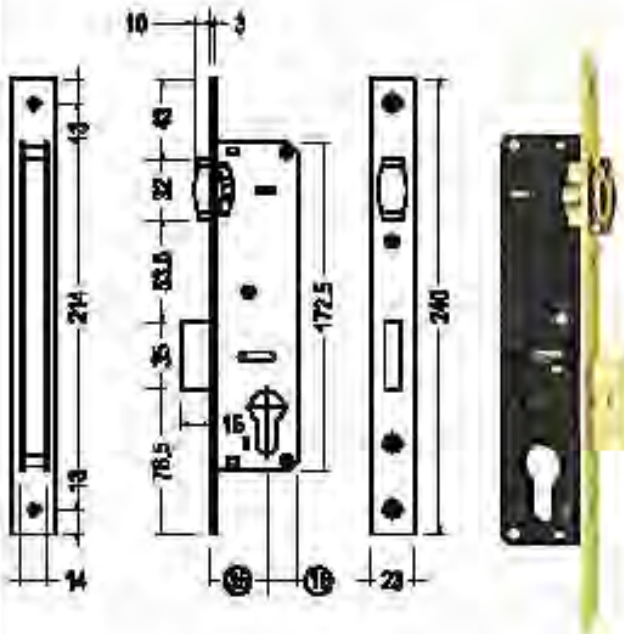

TYPE	B
155 36	36

CODE 155 35 Mortise Lock

CYLINDER	DOMUS 16053K
UNIT WEIGHT	830 gr
MATERIALS	Case : Steel , Electrostatic black powder painted
	Deadbolt : Zinc alloy
	Latch : MS 36 Brass

MORTISE LOCKS

DRAWING / INFORMATION

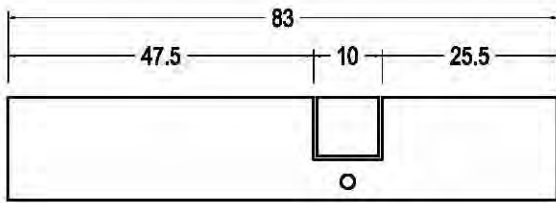

APPLICATION

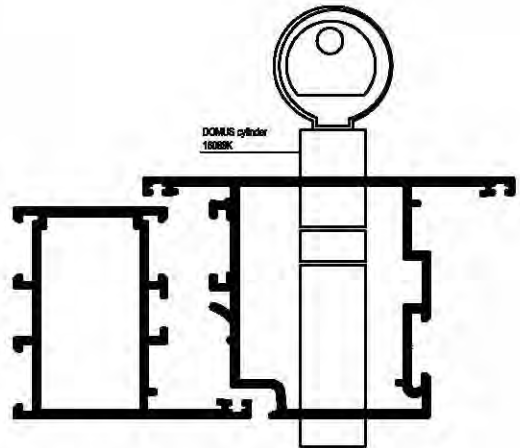
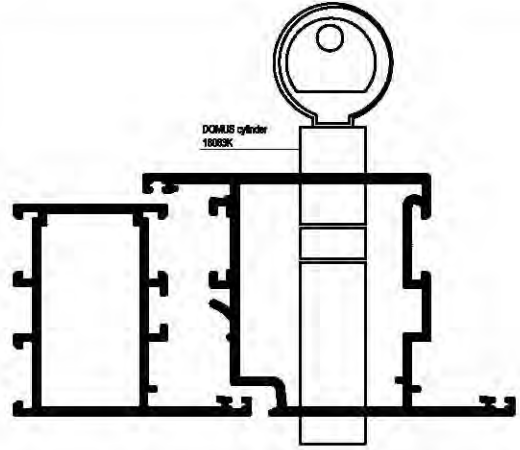

CODE	DOMUS 16083K	Cylinder
------	--------------	----------

MATERIALS	Lenght 83 mm
	Nickel

MORTISE LOCKS

DRAWING / INFORMATION

APPLICATION

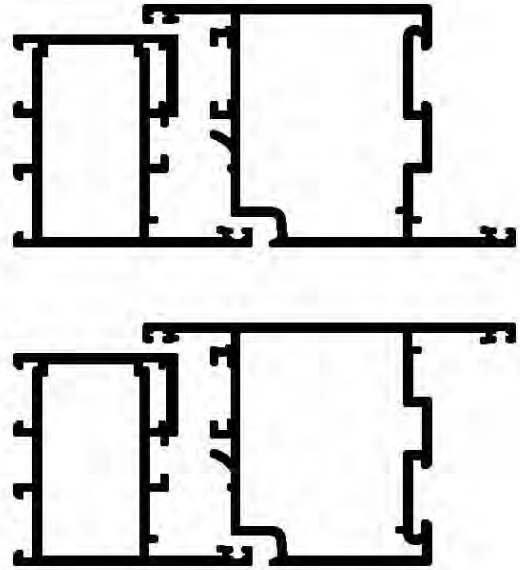
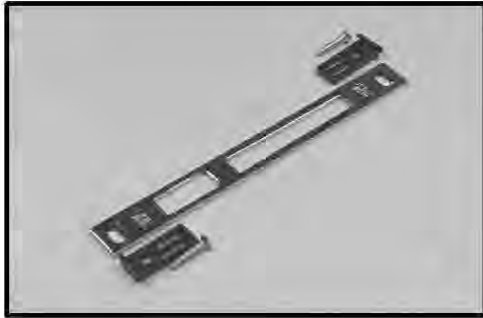

CODE AA 03205 Striking Plate

MATERIALS Chomized steel , 206.5 mm lenght
Black nylon bush

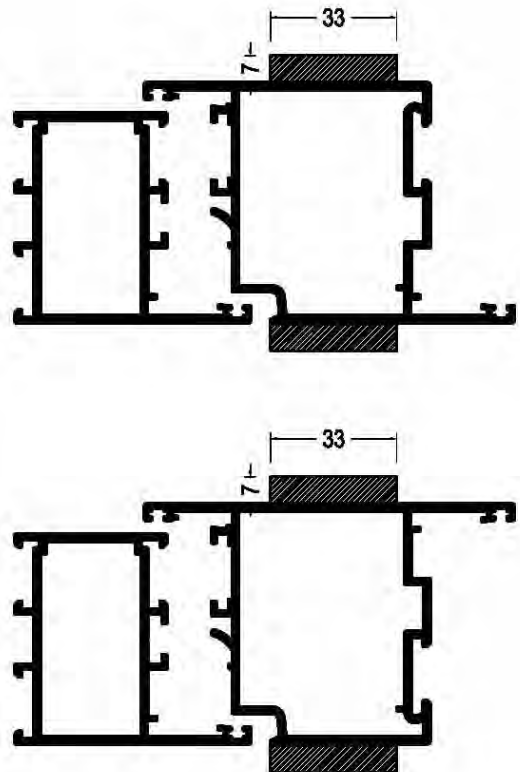

CODE

DRAWING / INFORMATION		APPLICATION	
			
CODE	GEZE TS 1000	CODE	2215 Bolt

d - TABLE

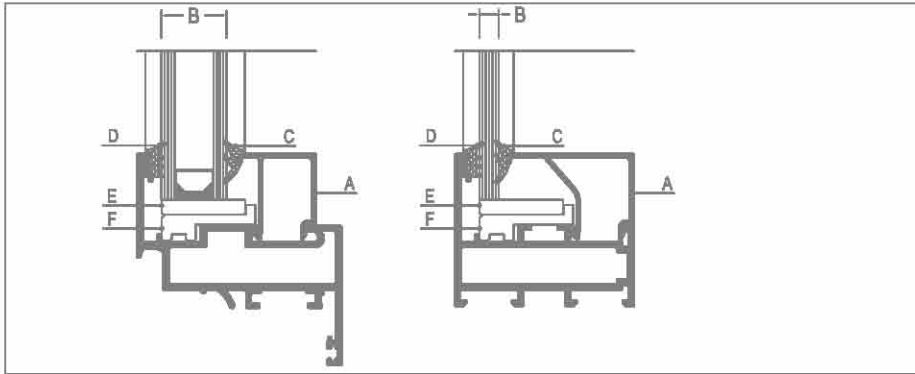

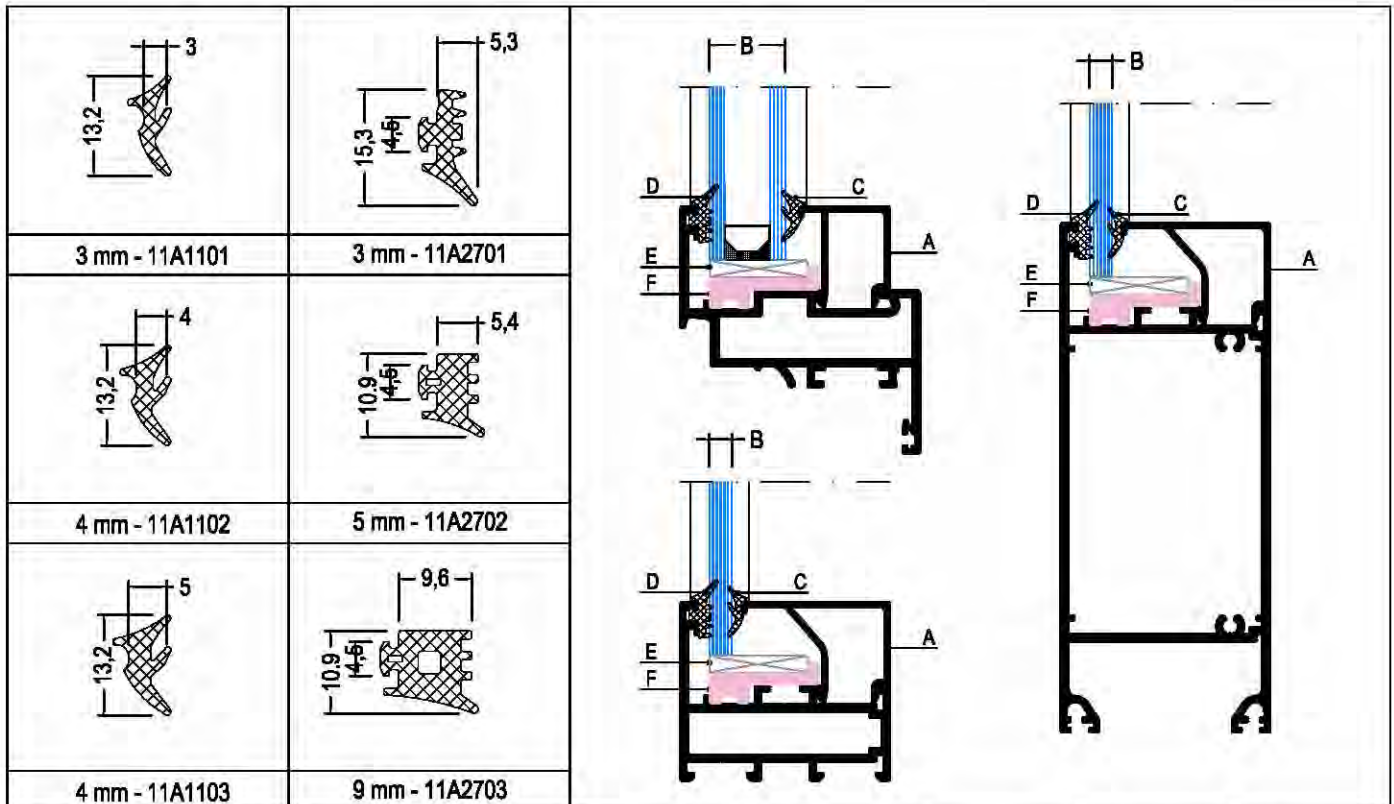

A GLAZING BEAD	B GLAZING THICKNESS	C GLAZING GASKET INSIDE	D GLAZING GASKET OUTSIDE	E WEDGES	F WEDGES	G WEDGES
14GW11	4 mm	11A1103	11A2701	17A1801	17A1805	---
14GW11	5 mm	11A1102	11A2701	17A1801	17A1805	---
14GW11	6 mm	11A1101	11A2701	17A1801	17A1805	---
14GW10	8 mm	11A1102	11A2701	17A1801	17A1805	---
14GW09	10 mm	11A1103	11A2701	17A1801	17A1805	---
14GW09	12 mm	11A1101	11A2701	17A1801	17A1805	---
14GW19	16 mm	11A1101	11A2701	17A1801	17A1805	---
14GW19	17 mm	11A1101	11A2701	17A1801	17A1805	---
14GW06	20 mm	11A1102	11A2701	17A1801	17A1805	---
14GW05	22 mm	11A1103	11A2701	17A1801	17A1805	---
14GW05	24 mm	11A1101	11A2701	17A1801	17A1805	---
14GW04	26 mm	11A1102	11A2701	17A1801	17A1805	---
14GW03	28 mm	11A1103	11A2701	17A1801	17A1805	---
14GW03	30 mm	11A1101	11A2701	17A1801	17A1805	---
14GW02	32 mm	11A1102	11A2701	17A1801	17A1805	---
14GW01	34 mm	11A1103	11A2701	17A1801	17A1805	---

e - DETAILS

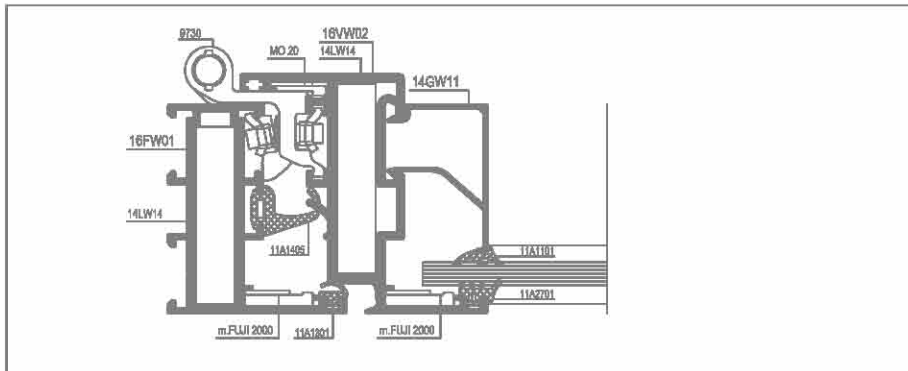

TURNING WINDOW

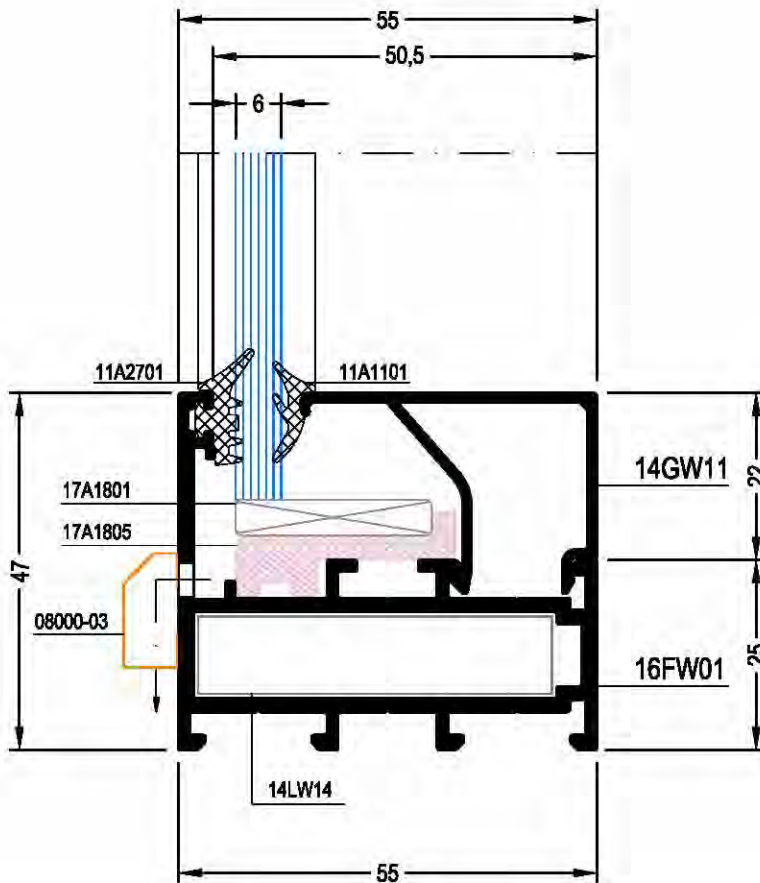
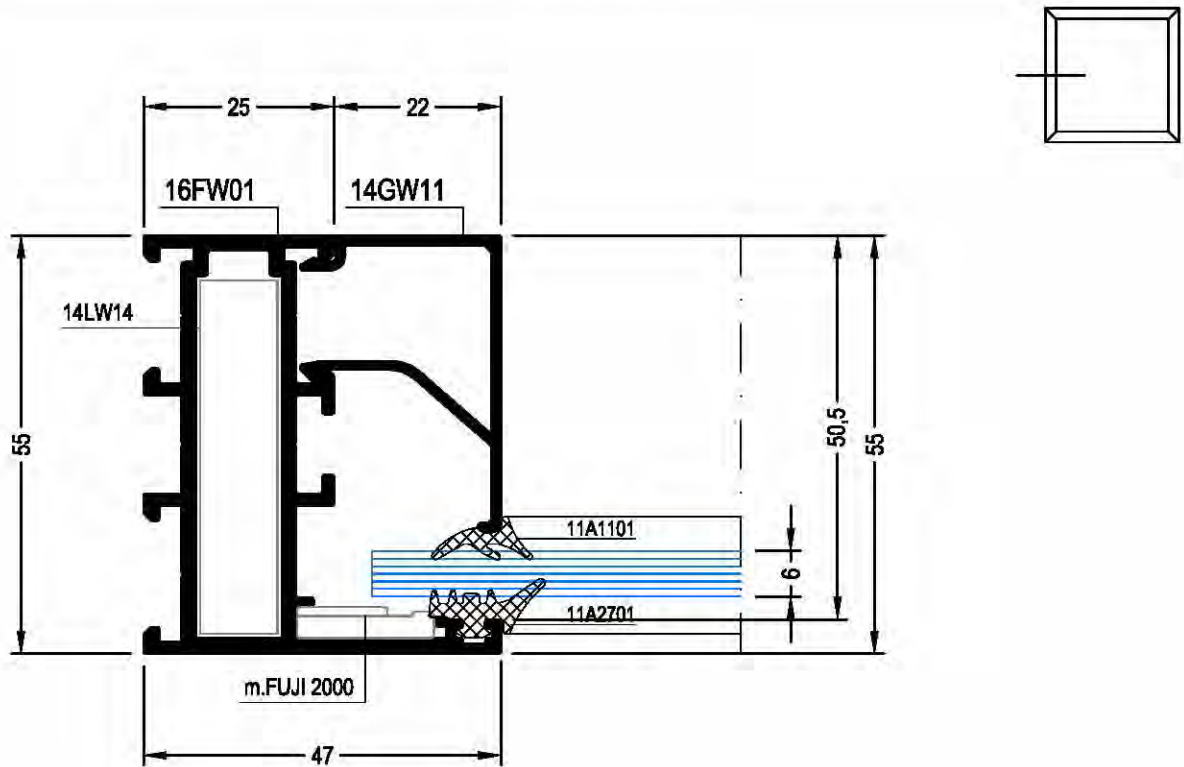

TURNING WINDOW

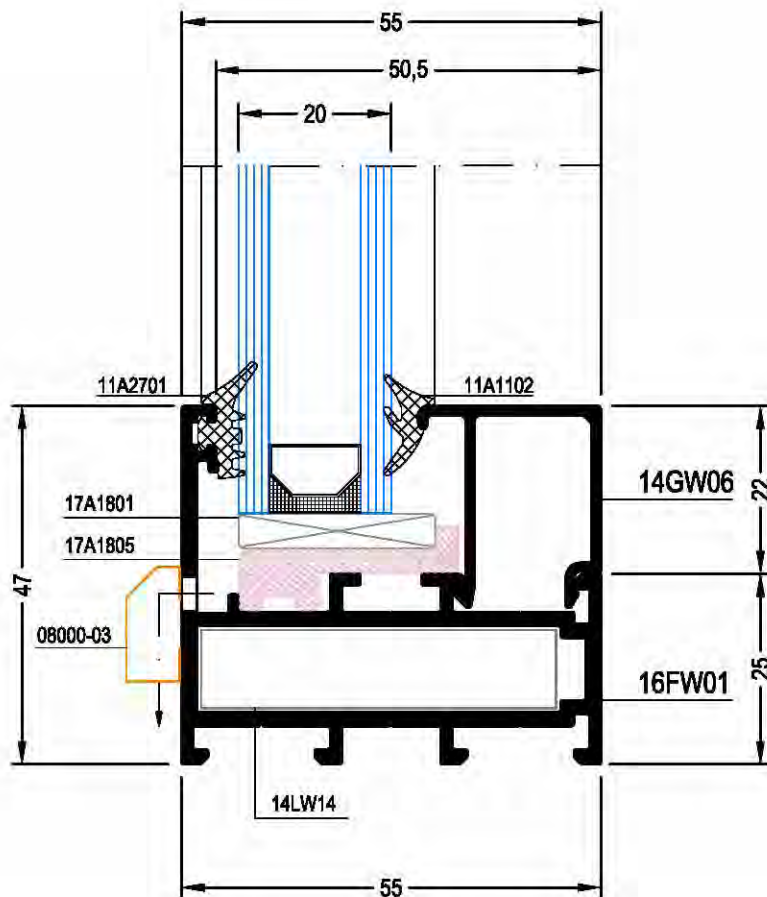
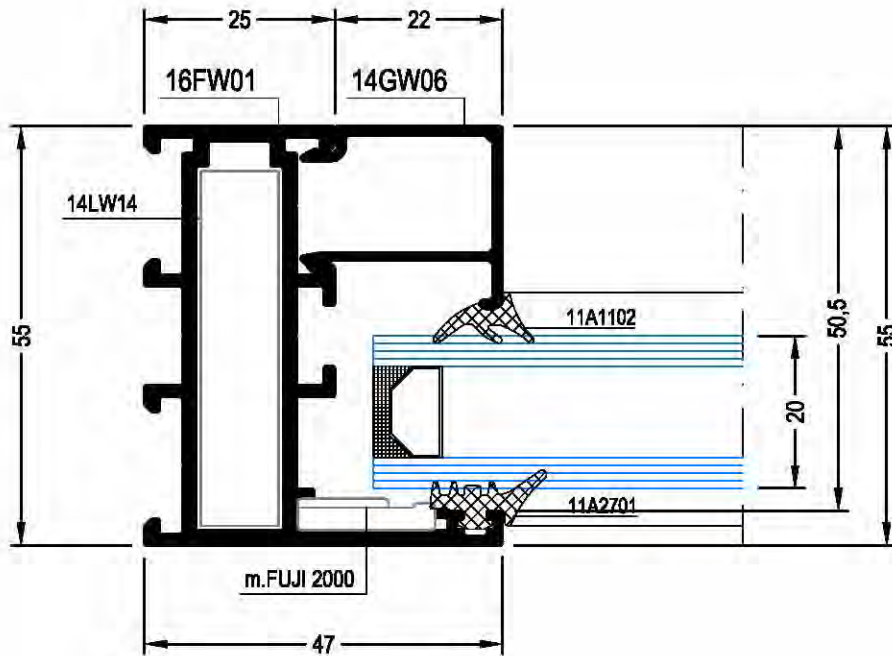
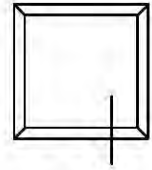

TURNING WINDOW

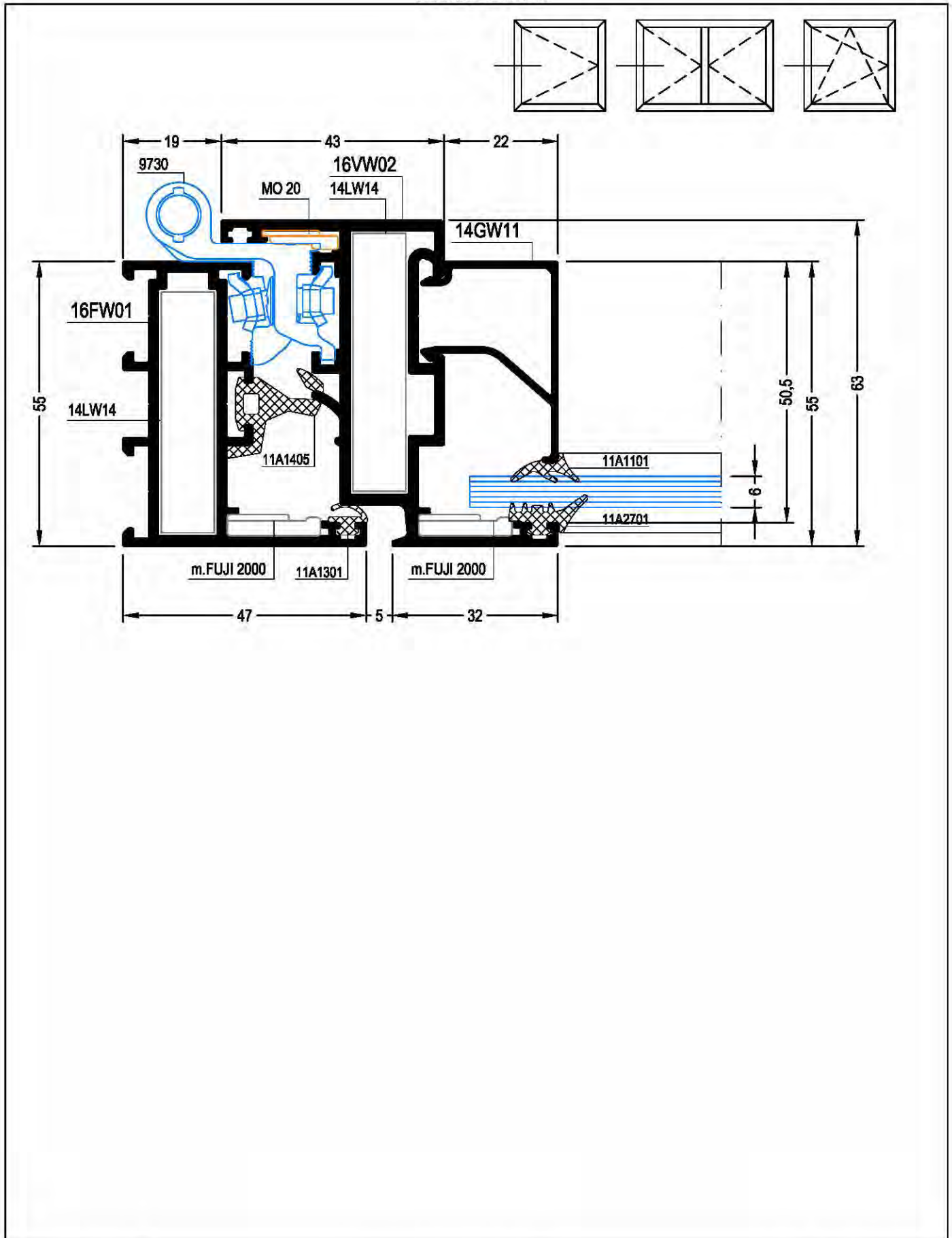

TURNING WINDOW

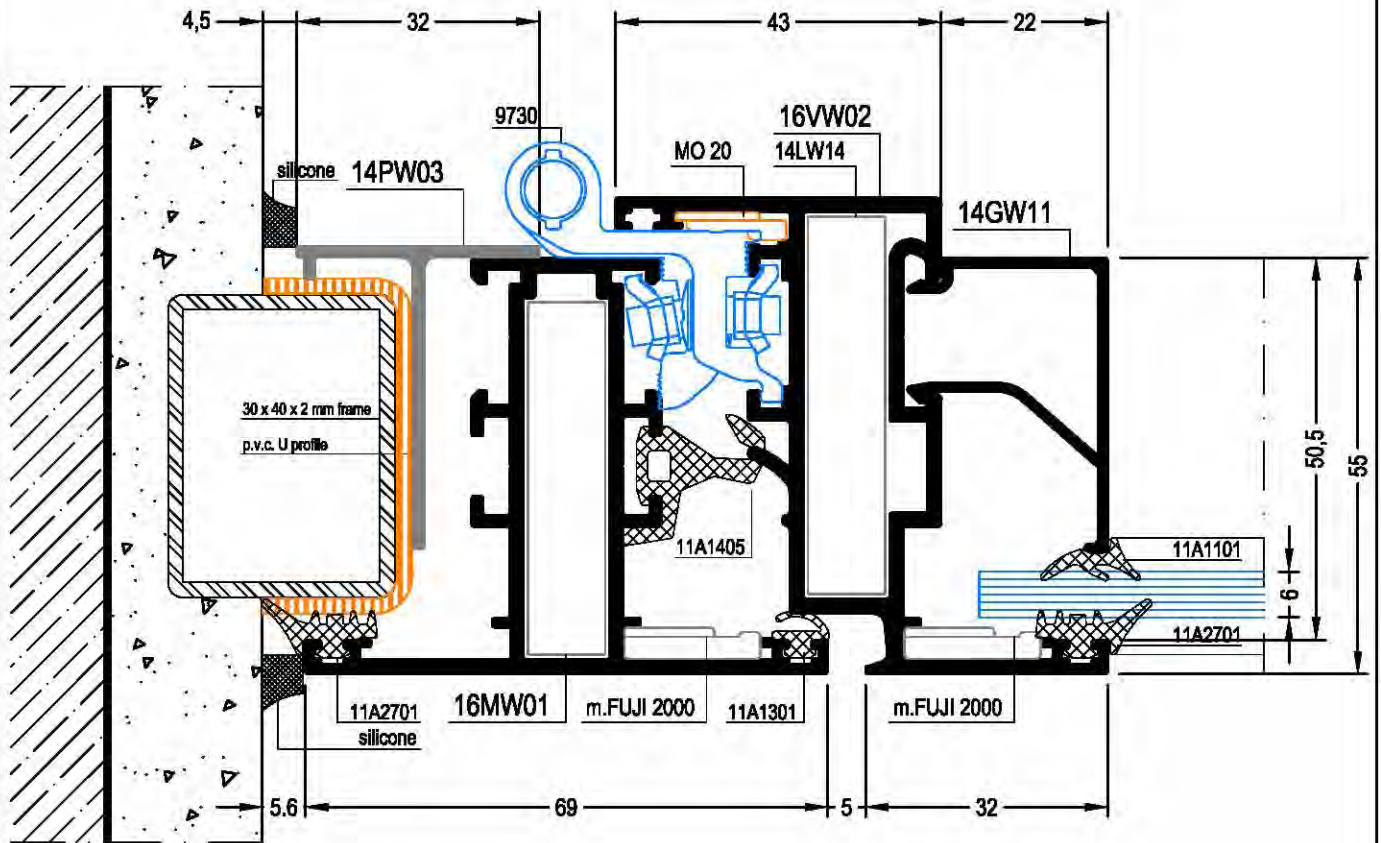
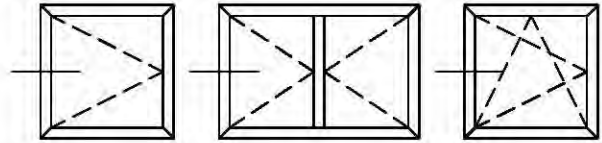

TURNING WINDOW

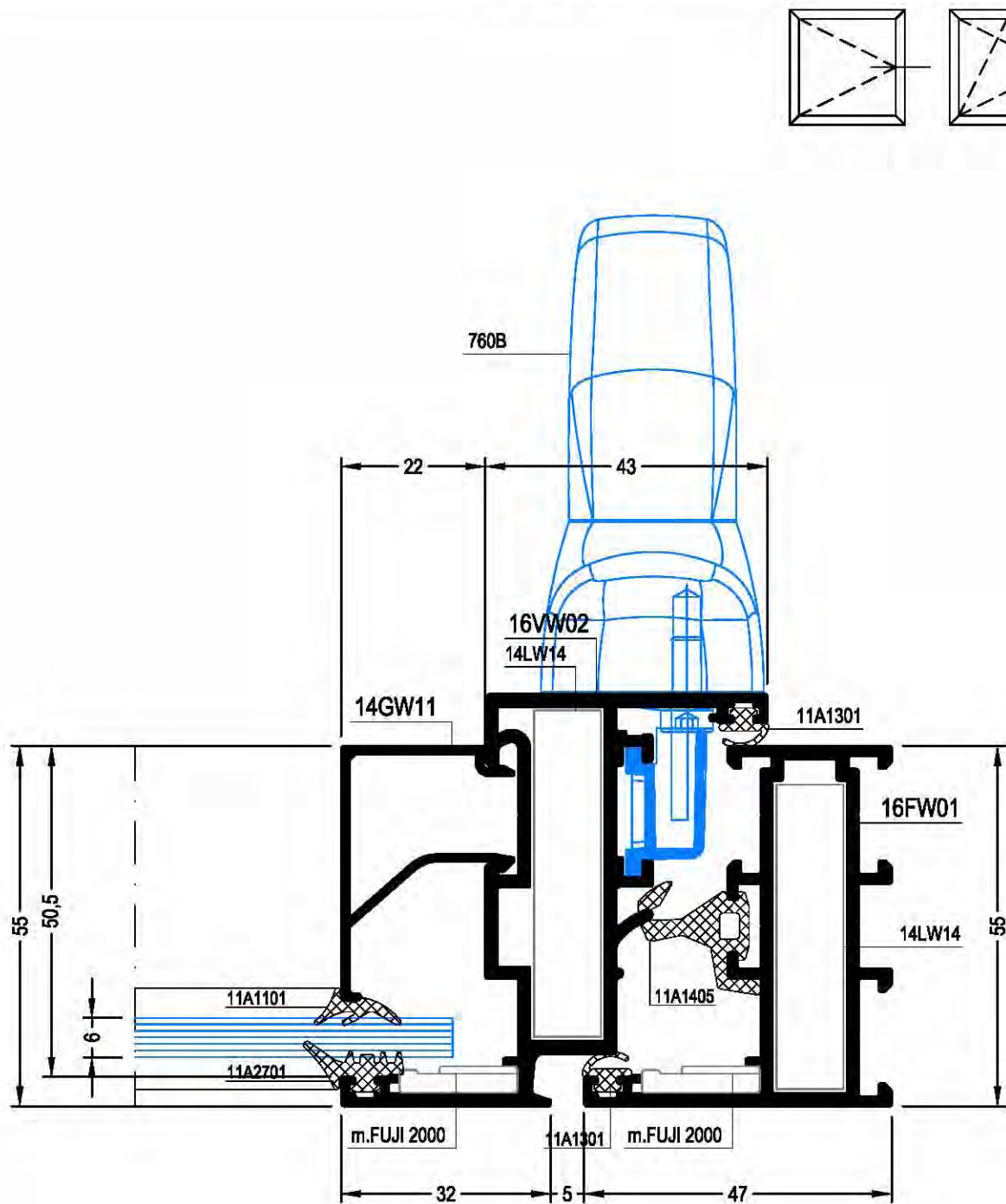

TURNING WINDOW

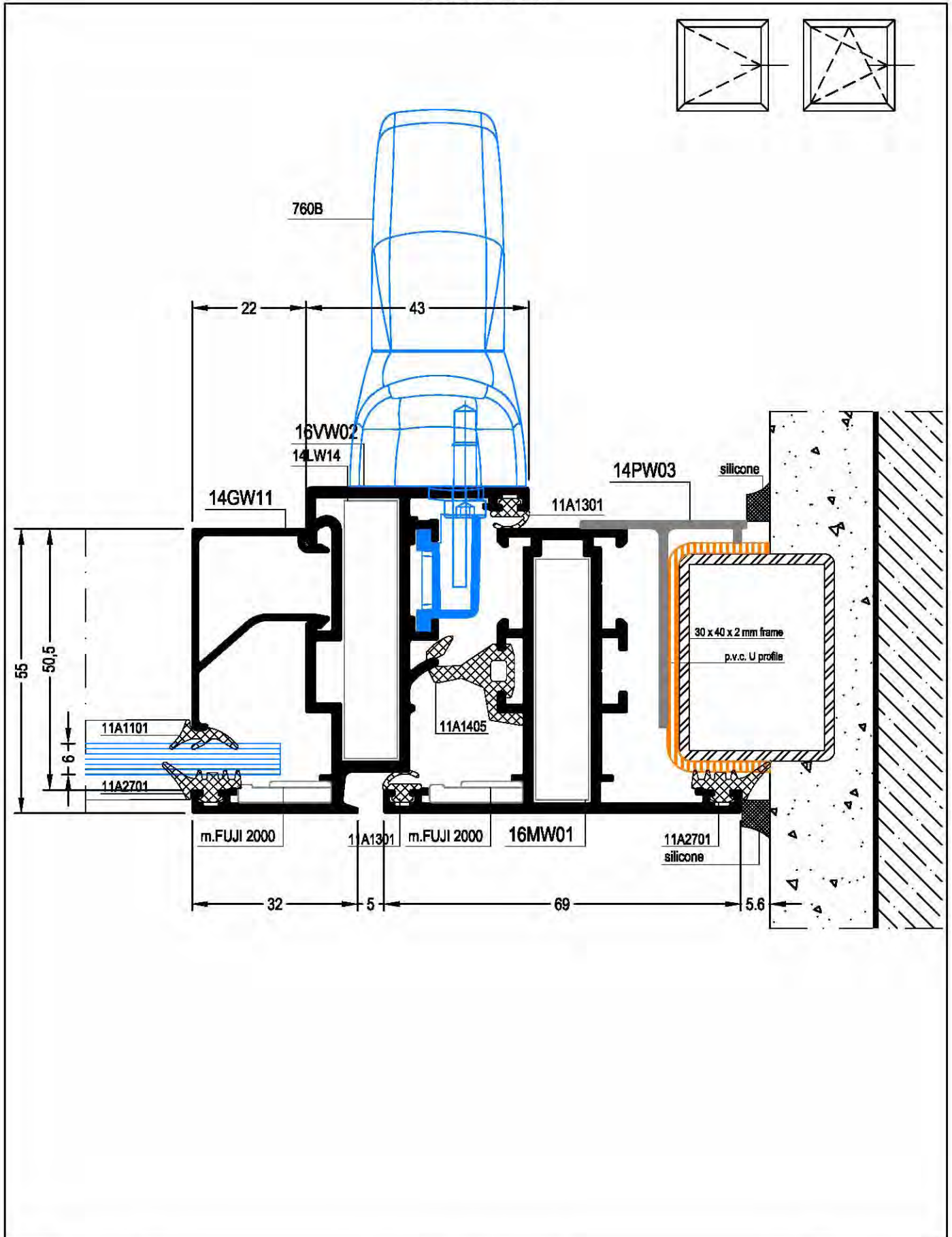

TURNING WINDOW

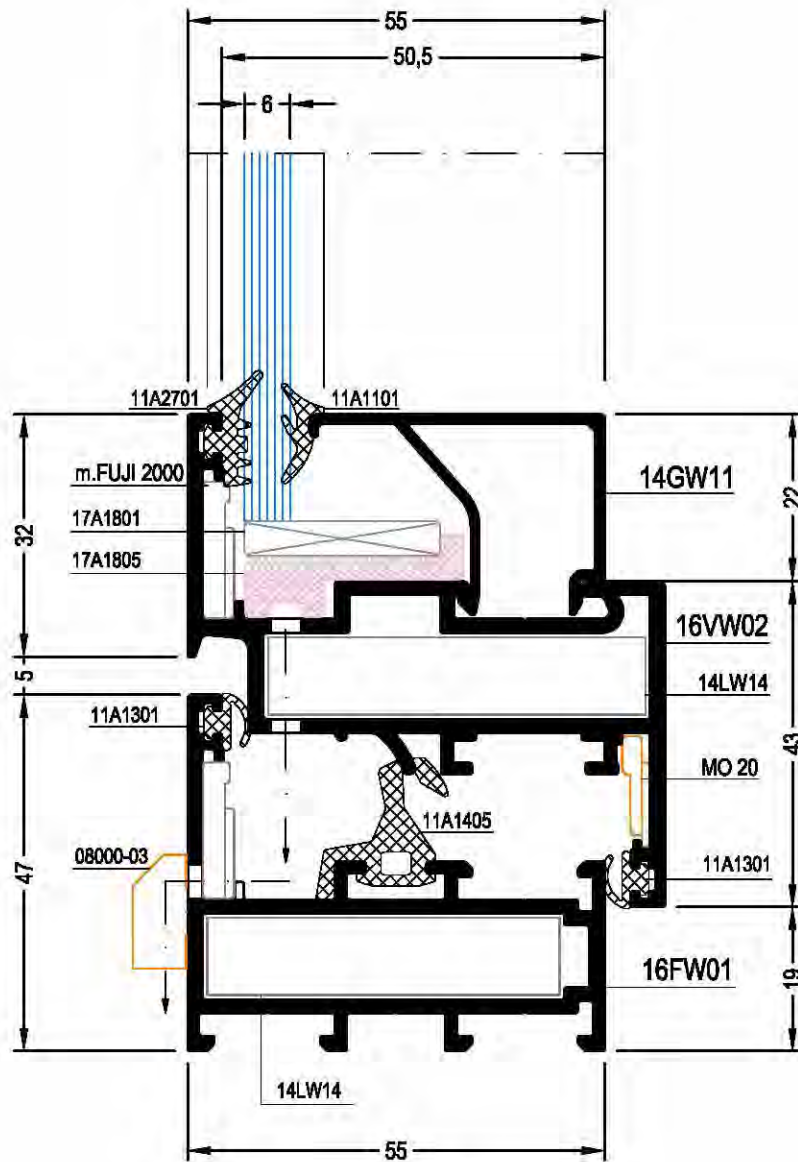
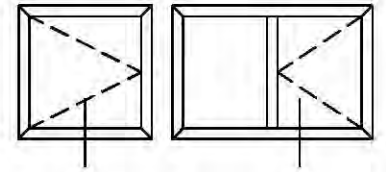

TURNING WINDOW

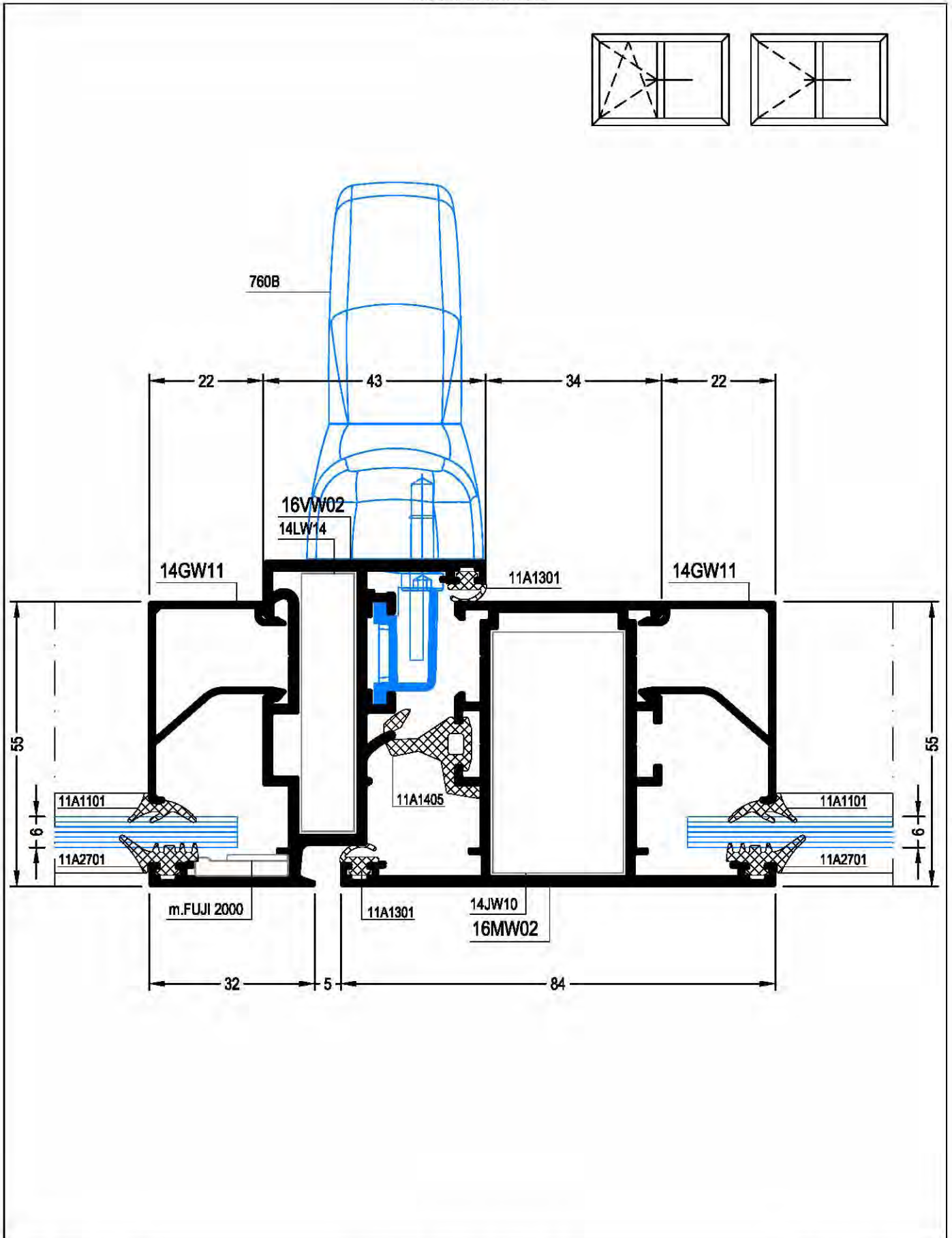

TURNING WINDOW

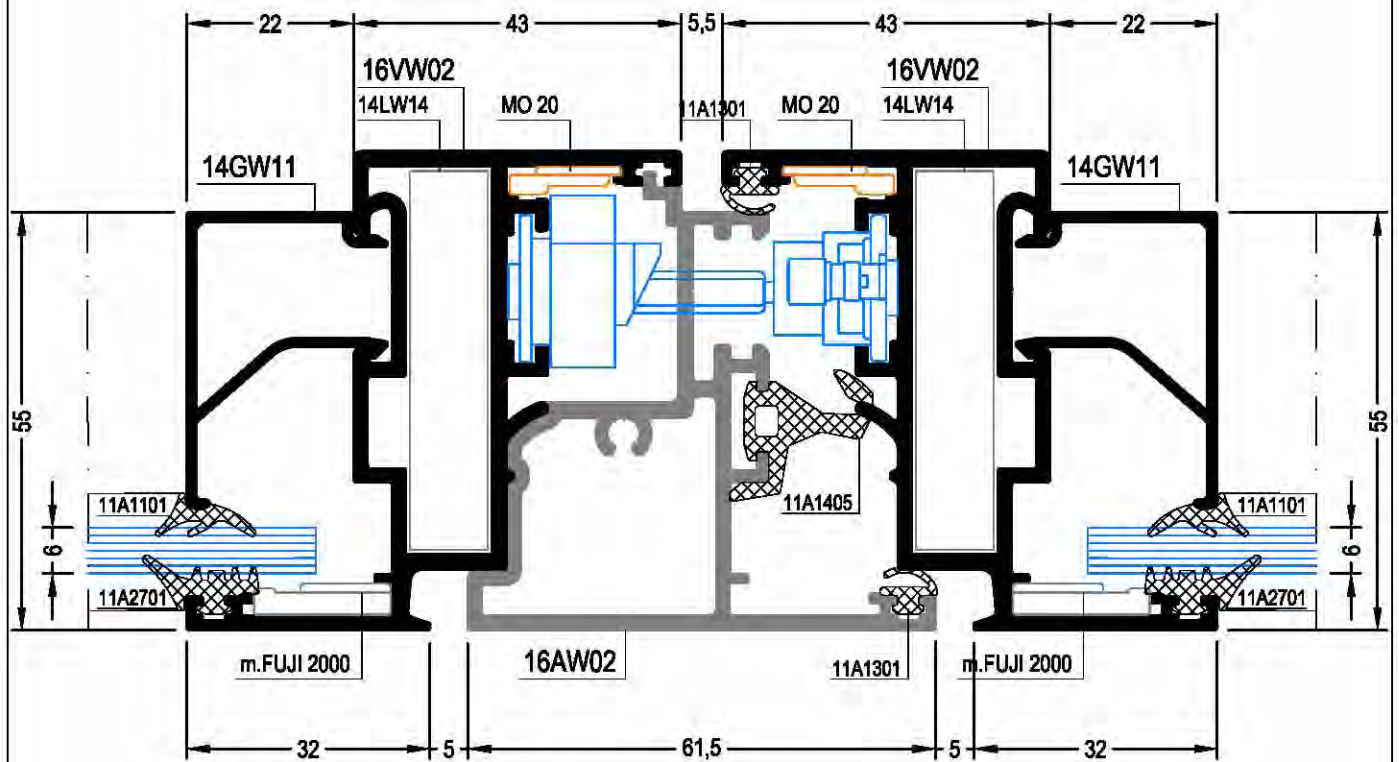
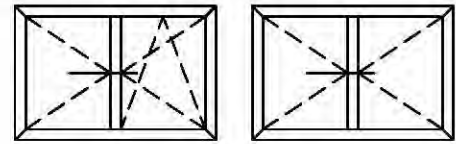

TURNING WINDOW

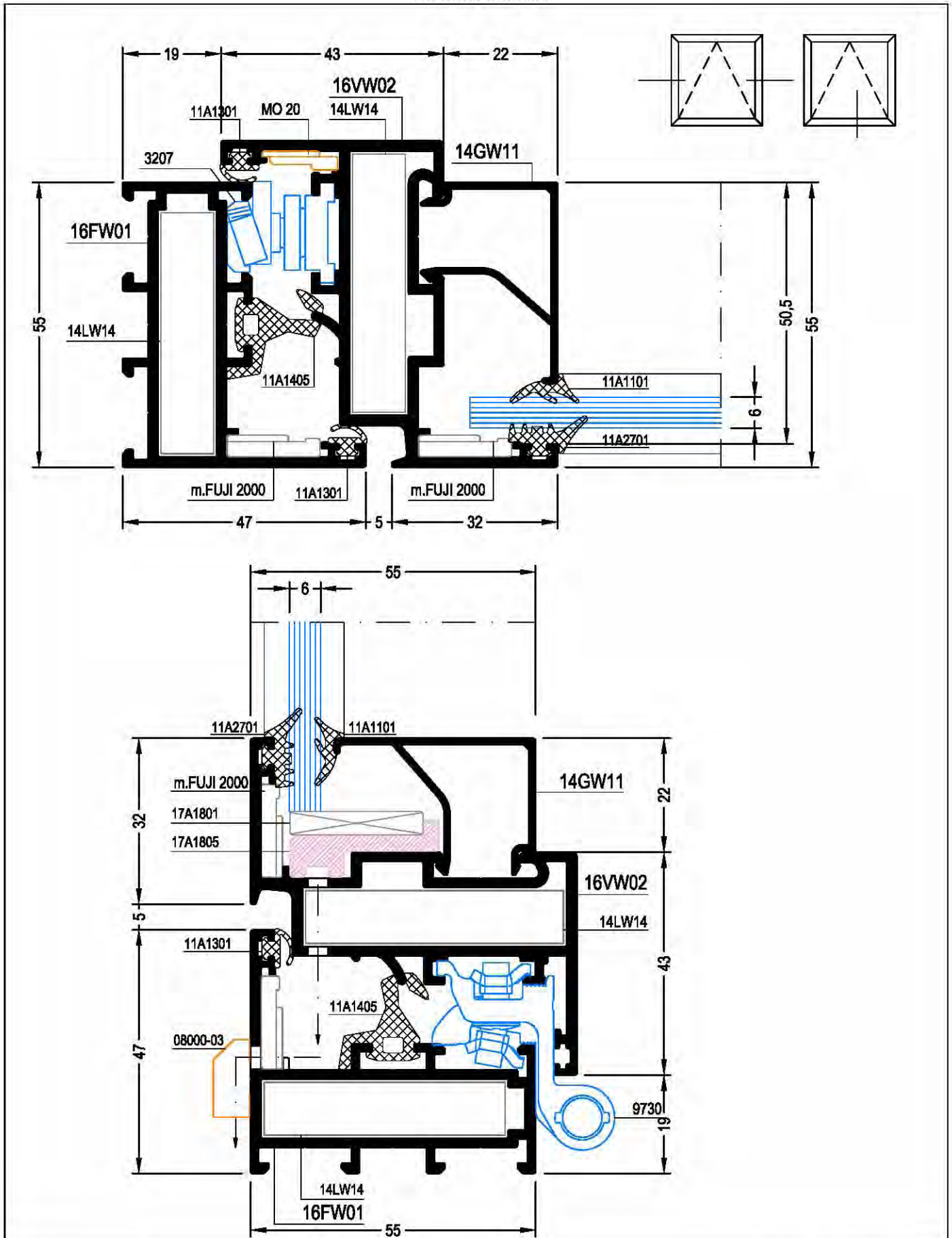

TURNING WINDOW

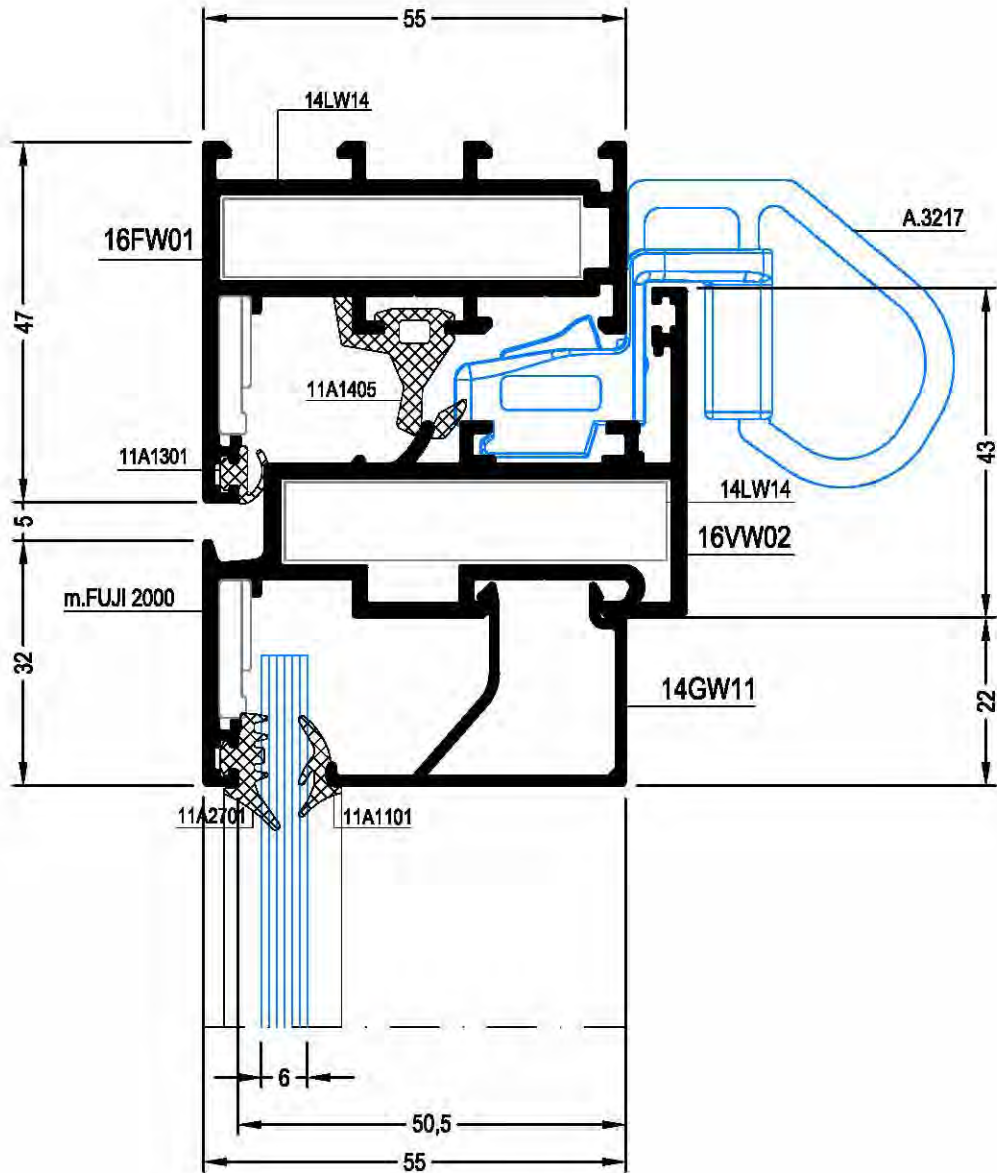
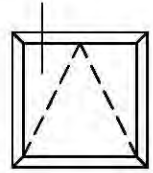

TURNING WINDOW

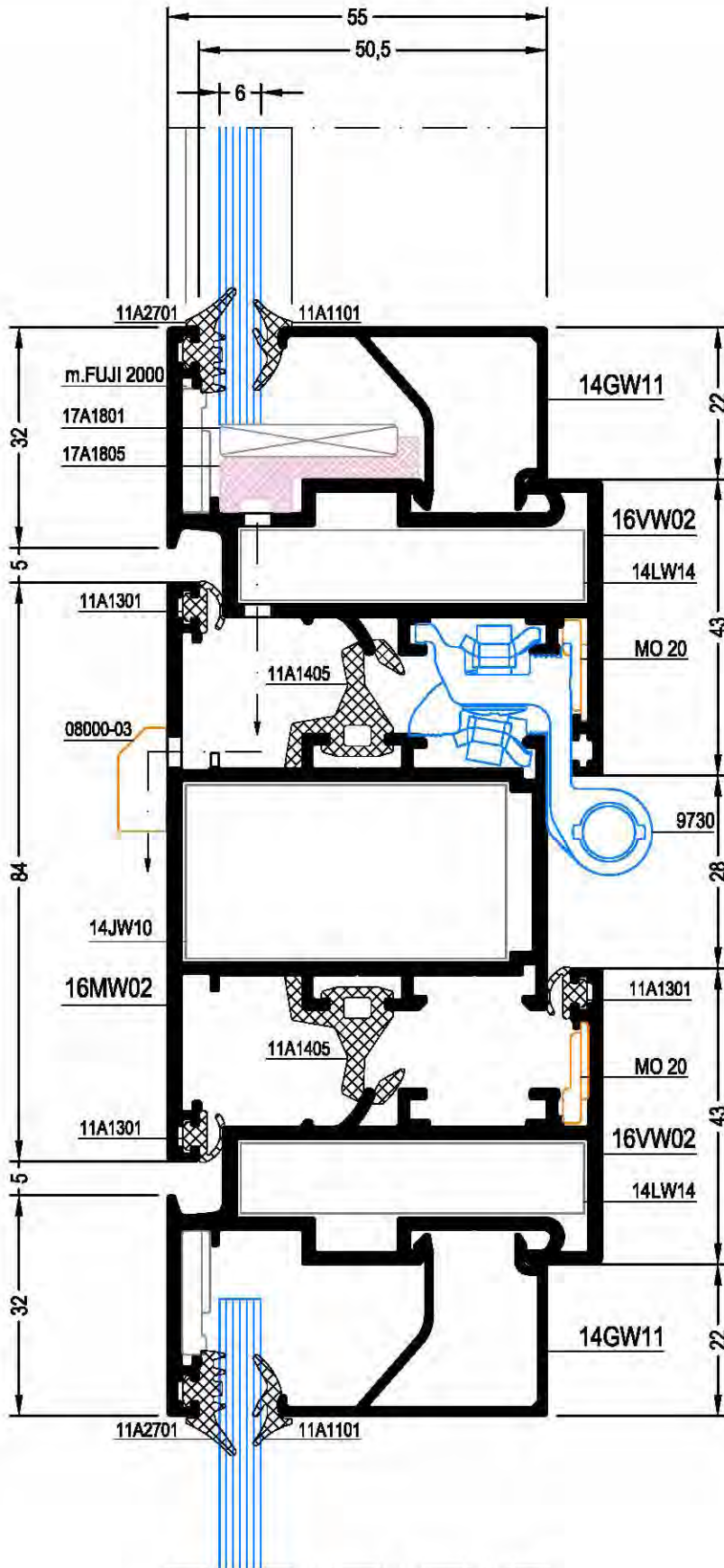

TURNING WINDOW

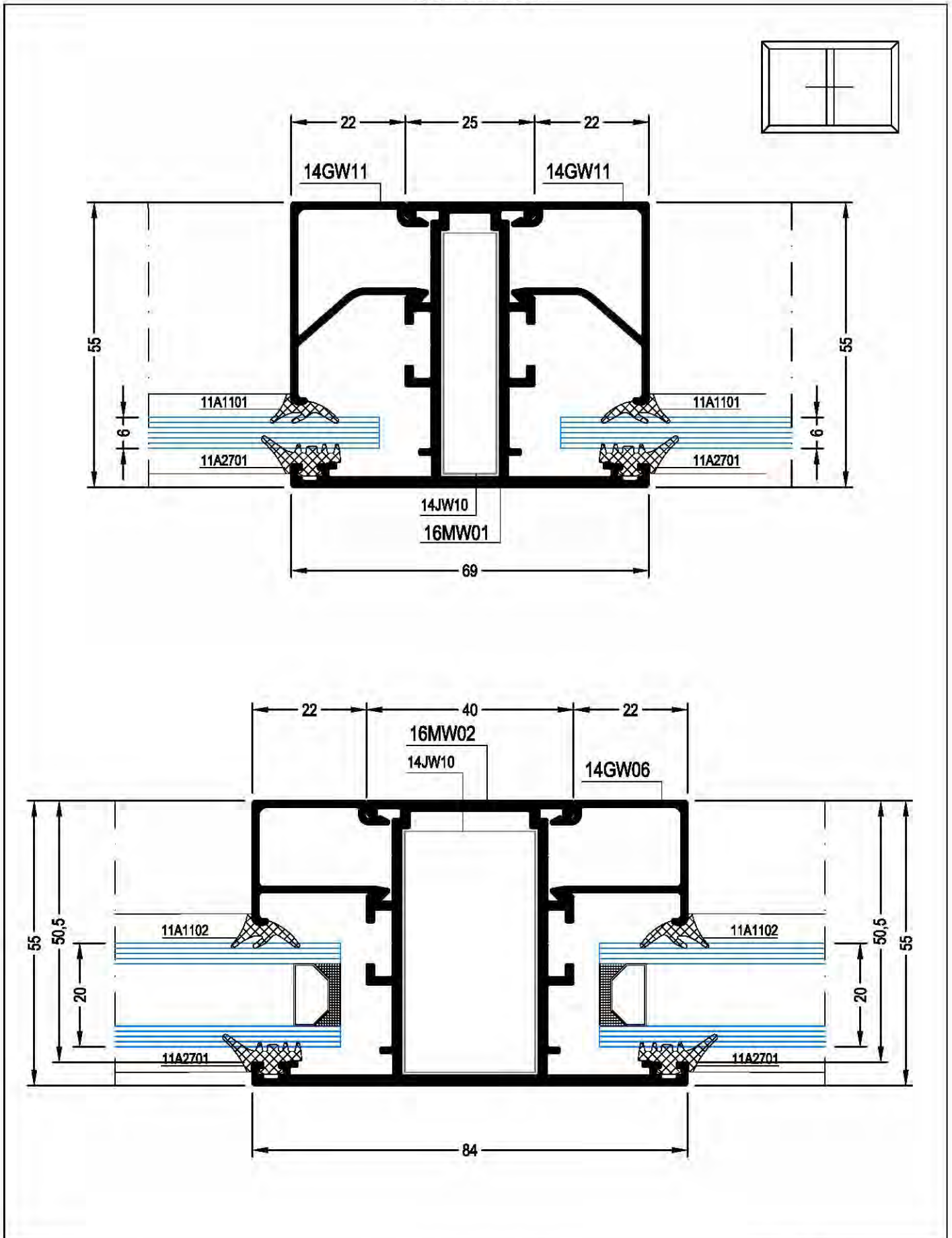

TURNING WINDOW

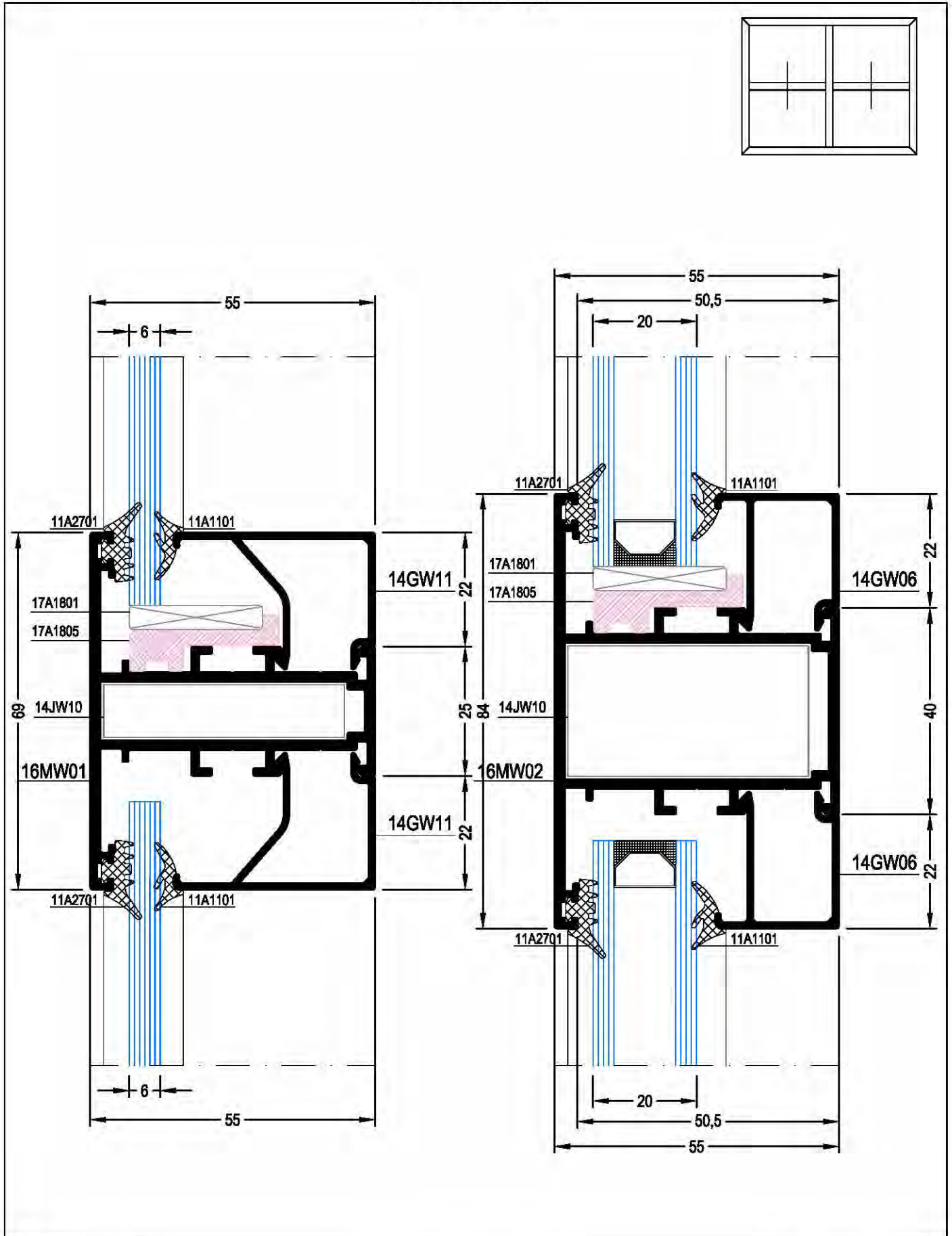

TURNING WINDOW

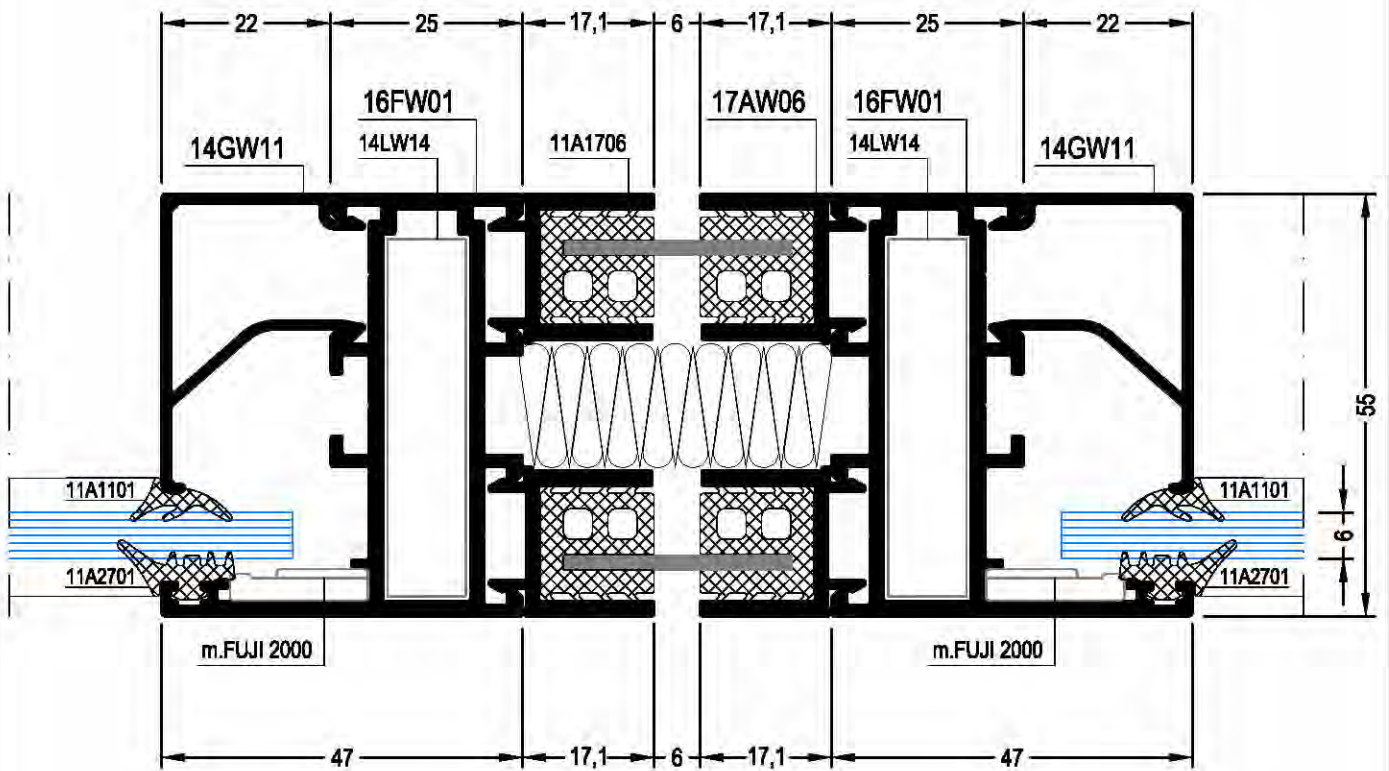
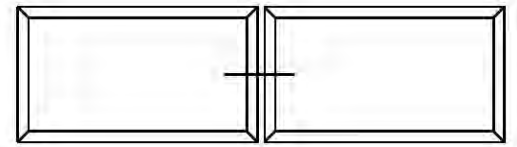

INSIDE OPENING DOOR

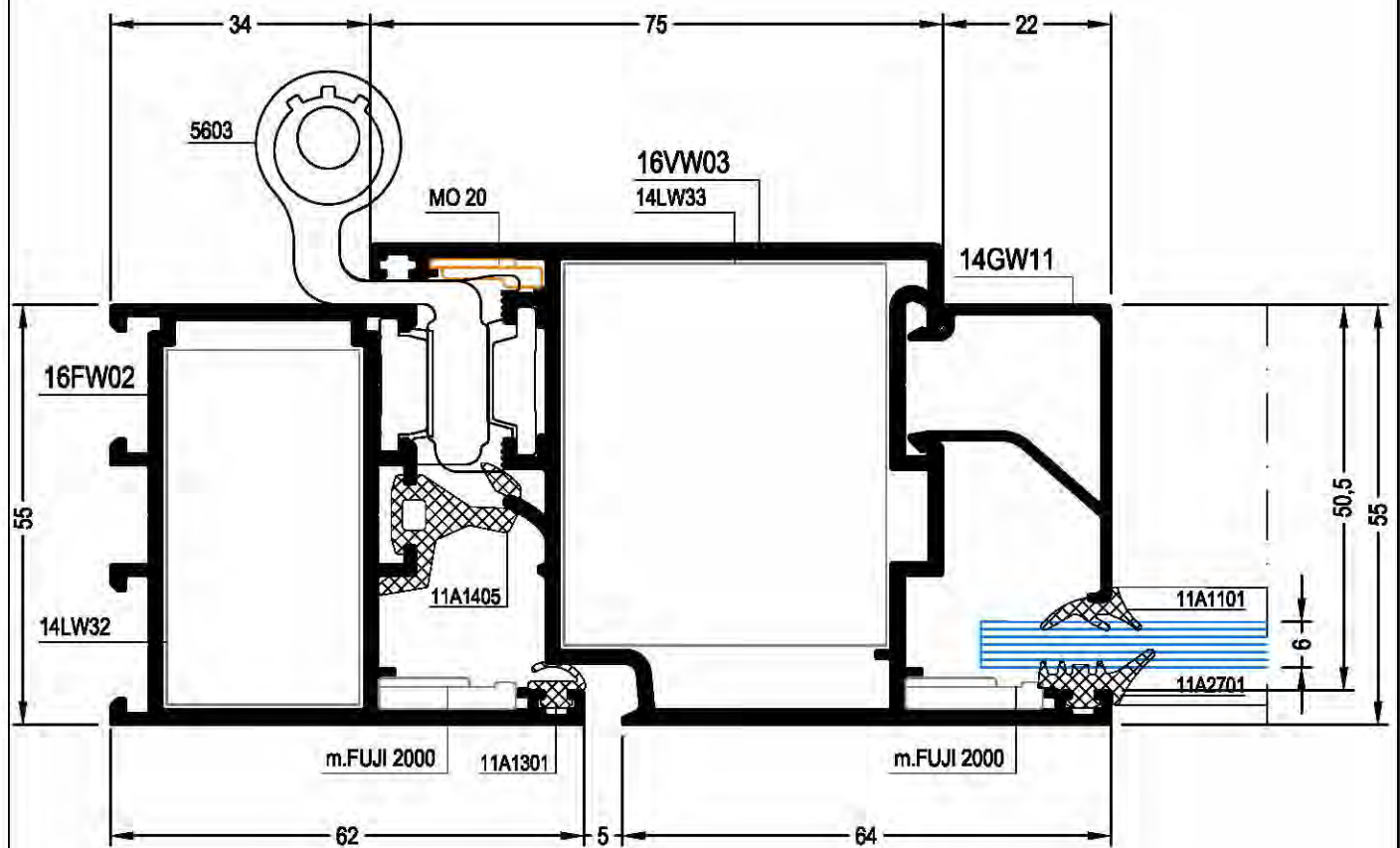
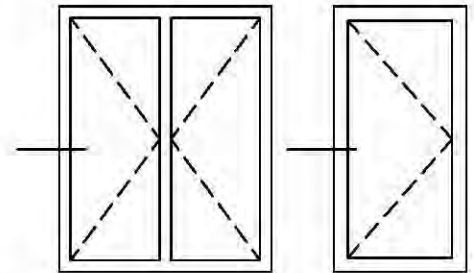

INSIDE OPENING DOOR

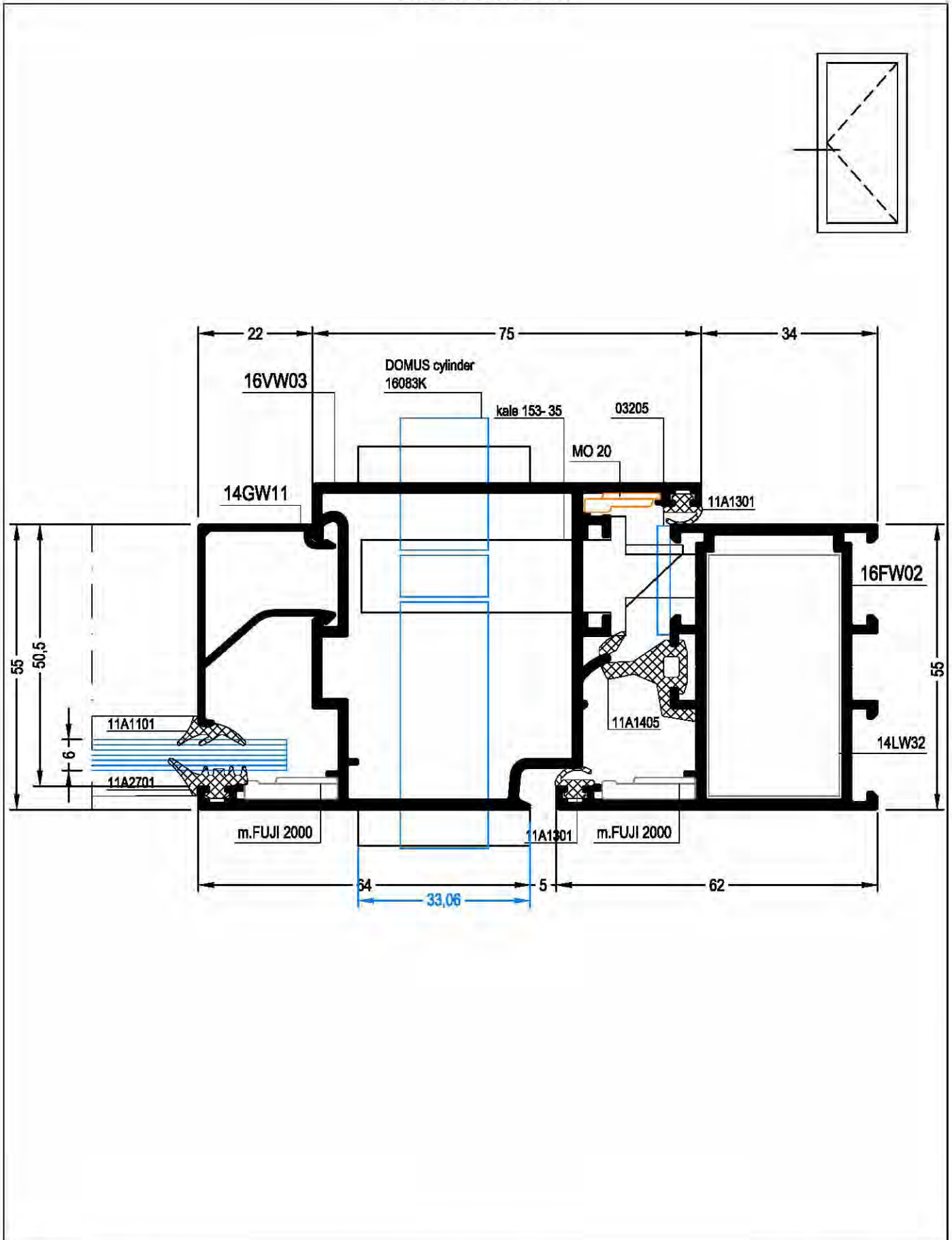

INSIDE OPENING DOOR

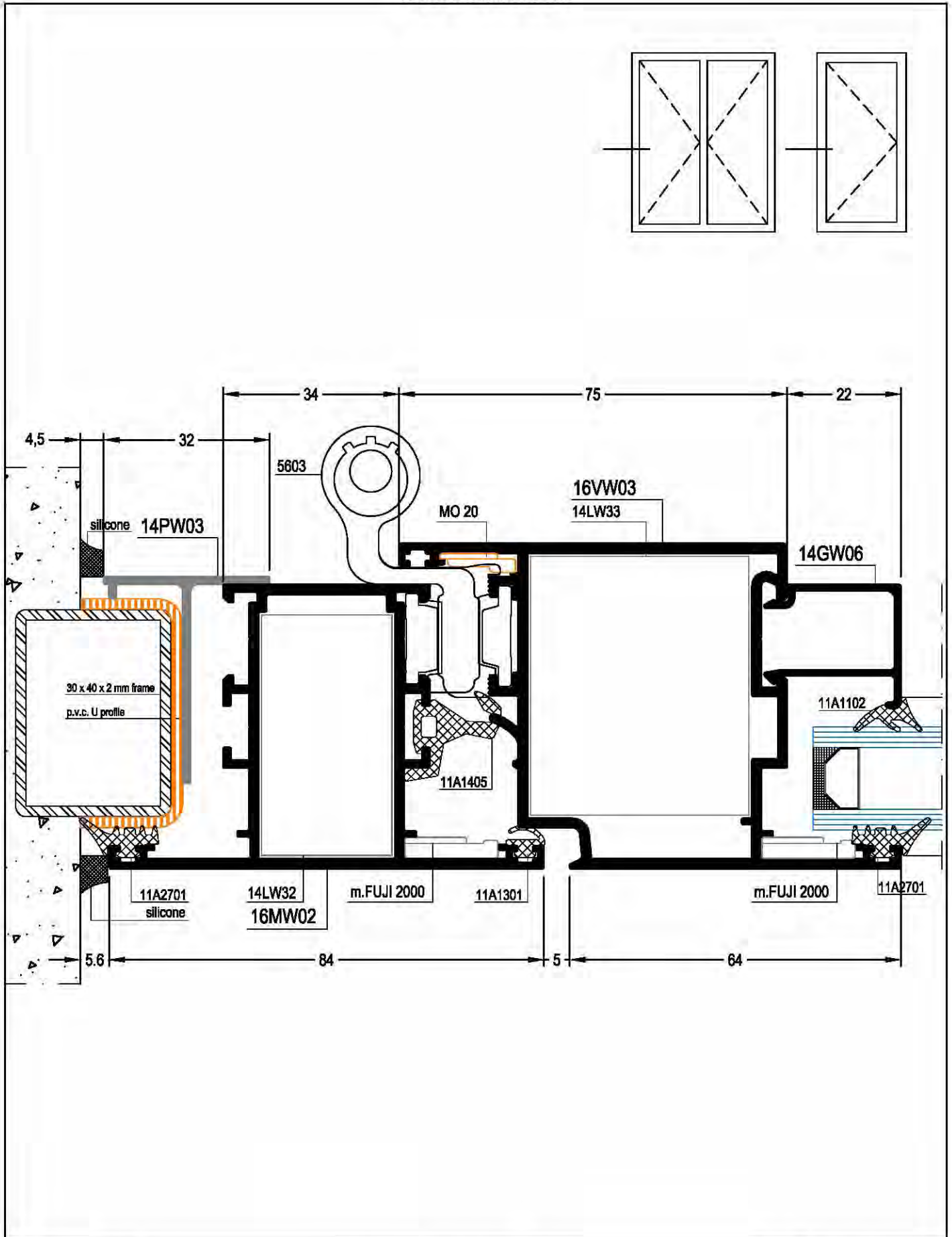

INSIDE OPENING DOOR

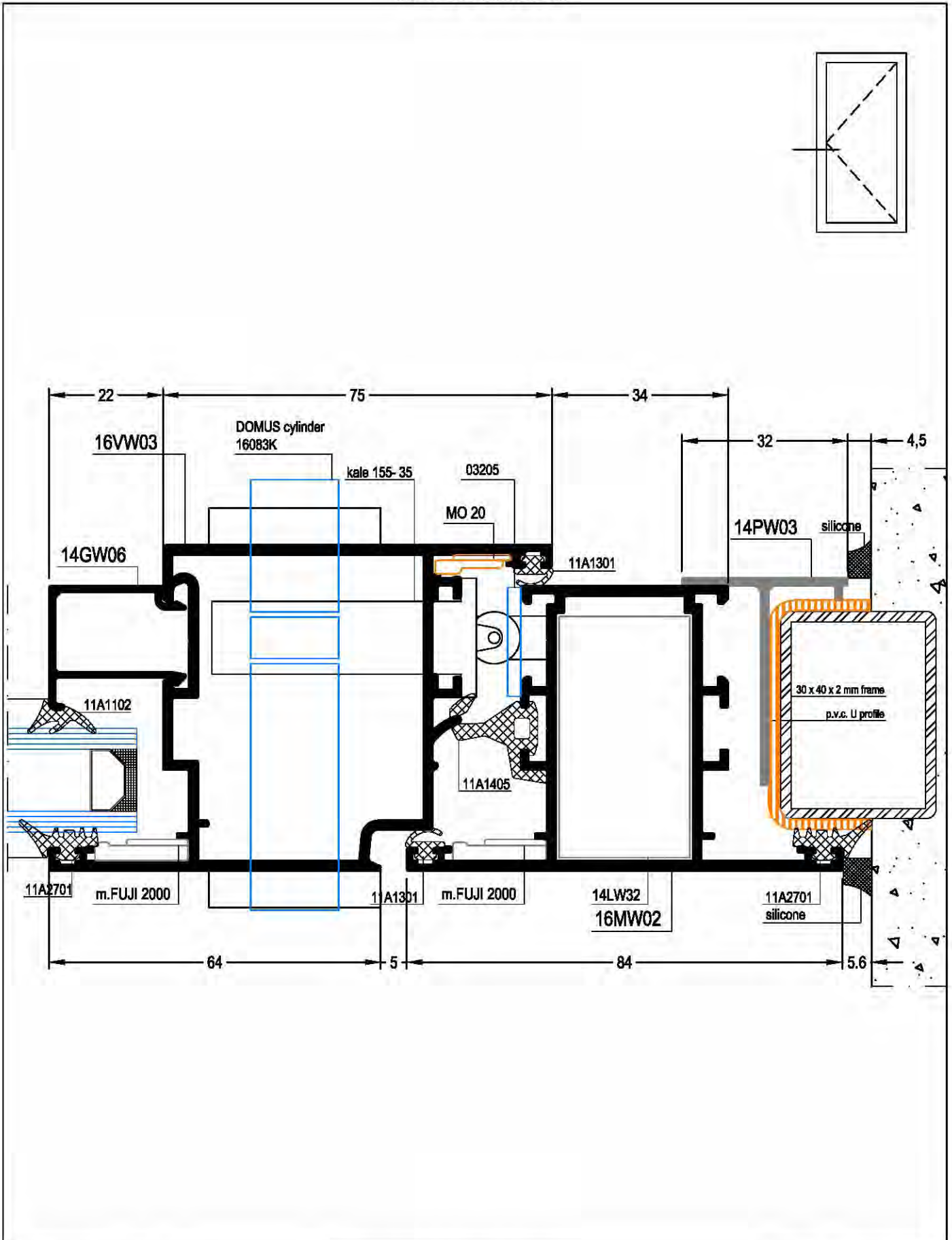

INSIDE OPENING DOOR

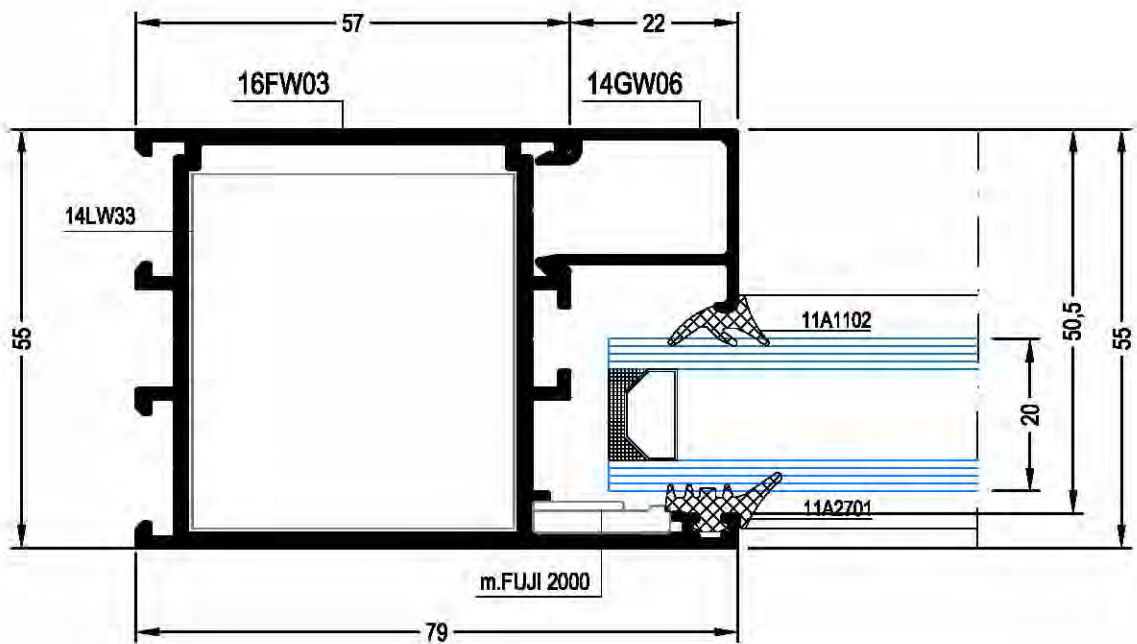
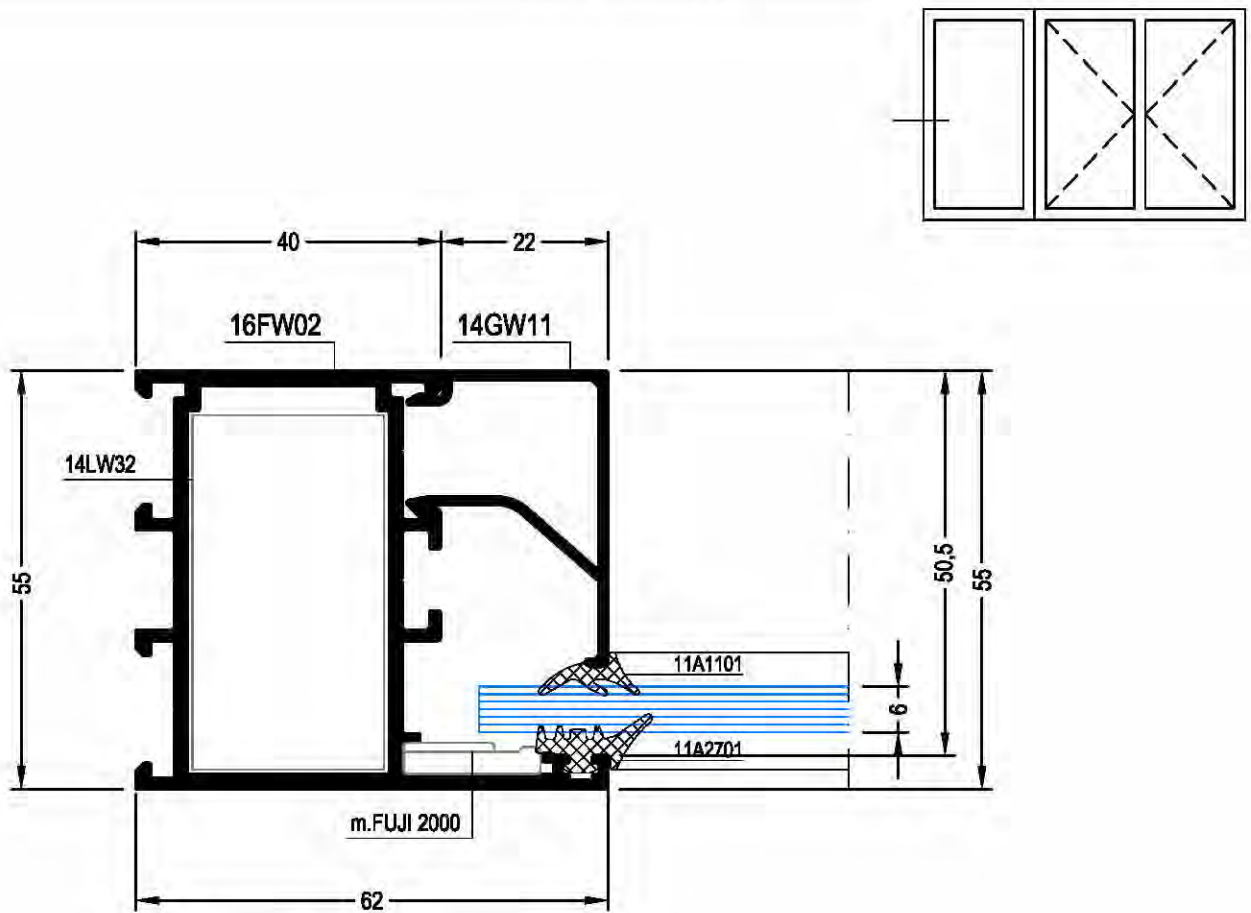

INSIDE OPENING DOOR

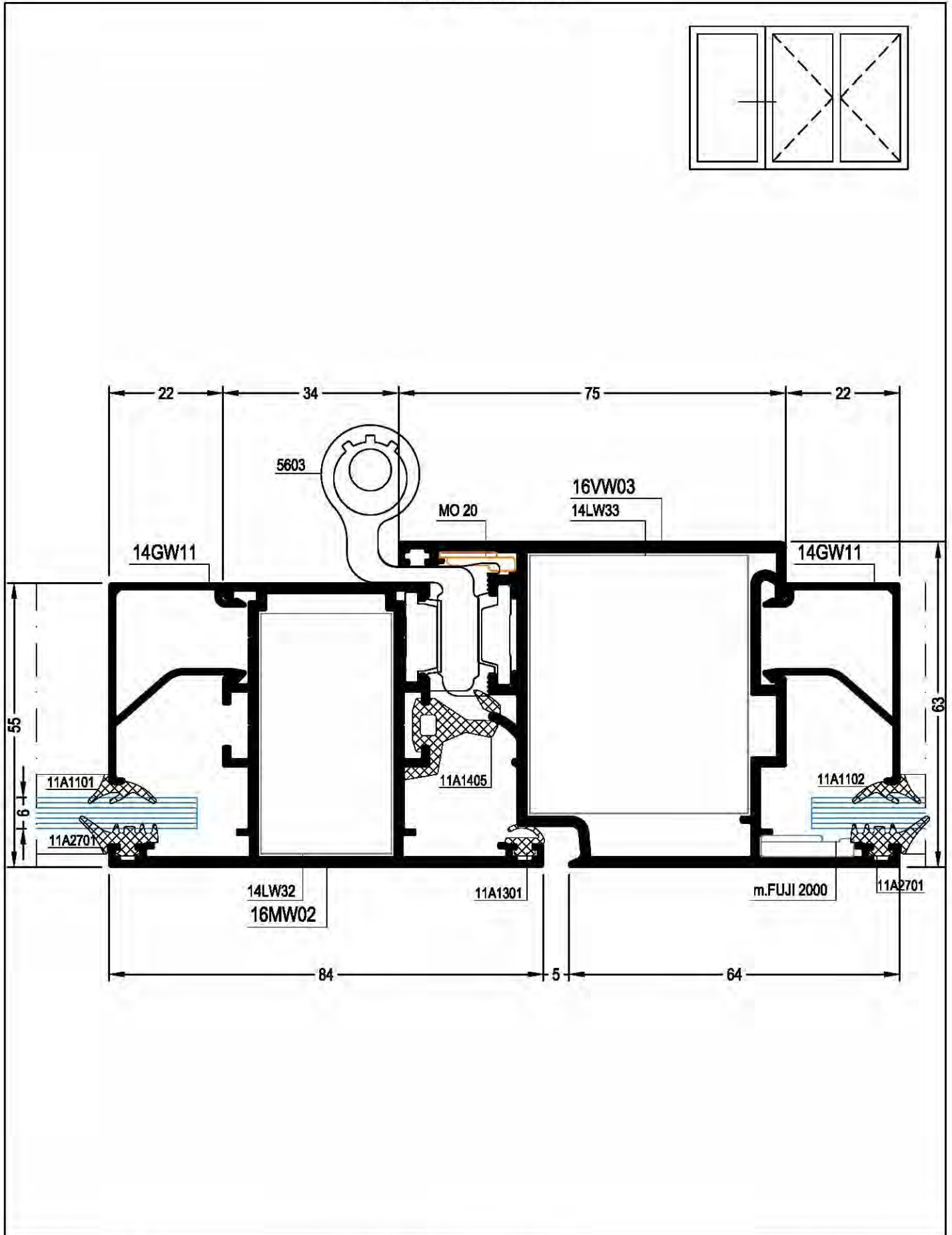

INSIDE OPENING DOOR

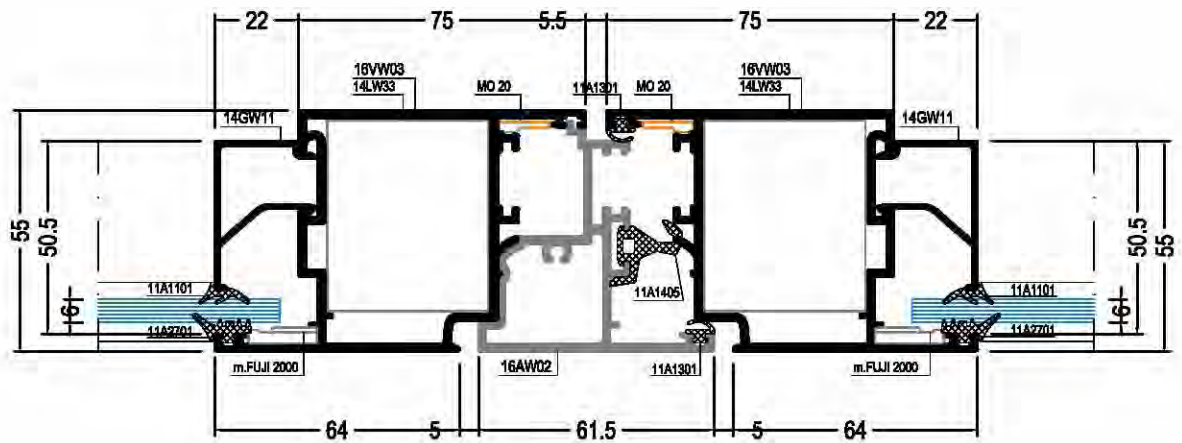
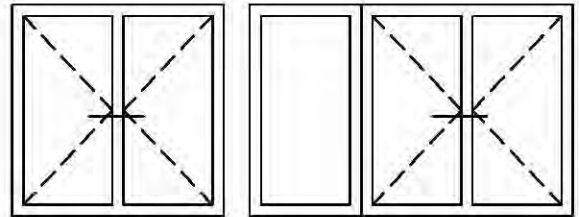

SYSTEM CASTLE 1655 W

DETAILS

INSIDE OPENING DOOR

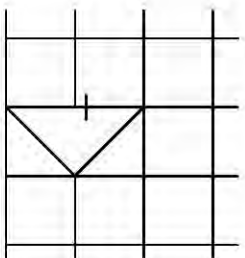
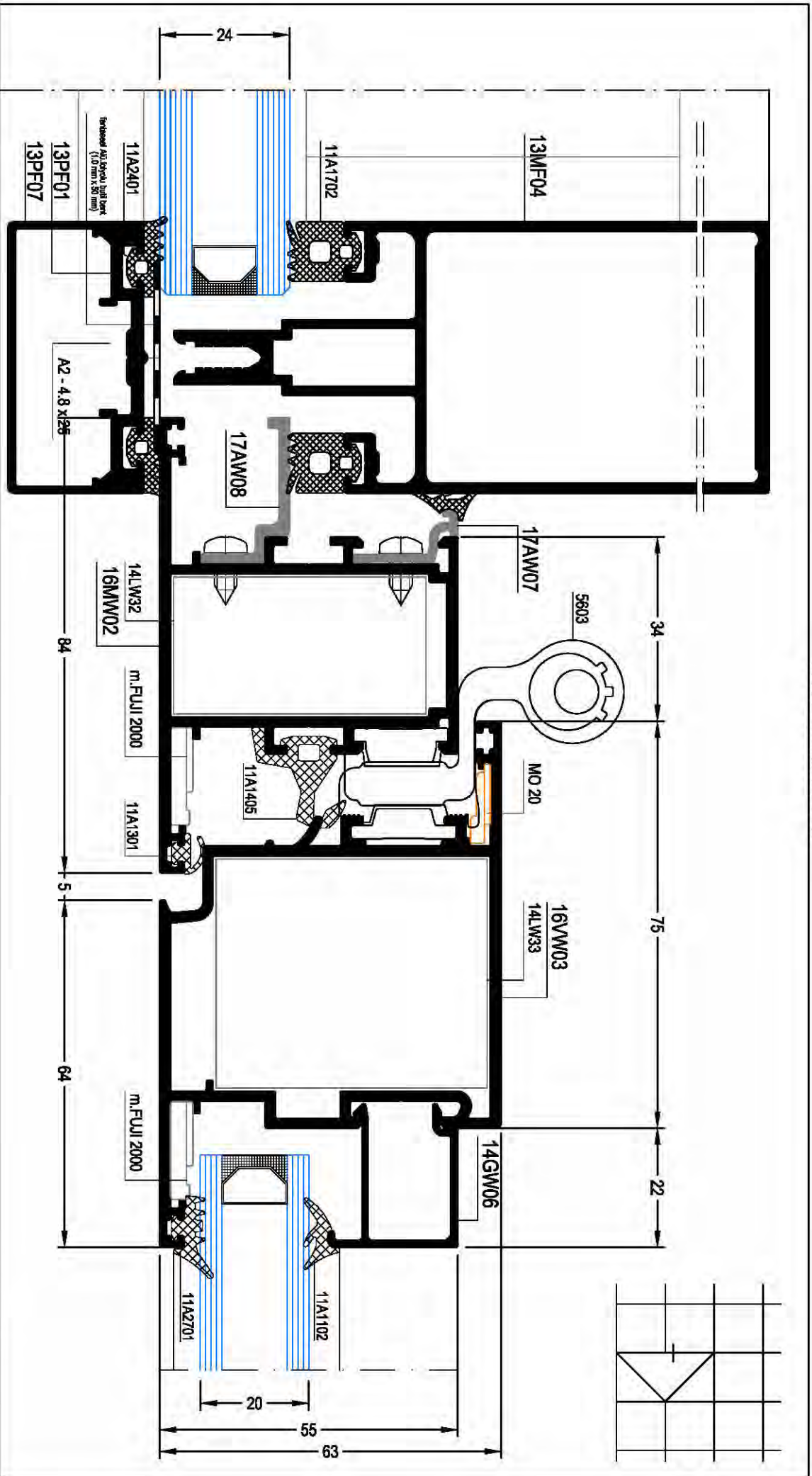

INSIDE OPENING DOOR

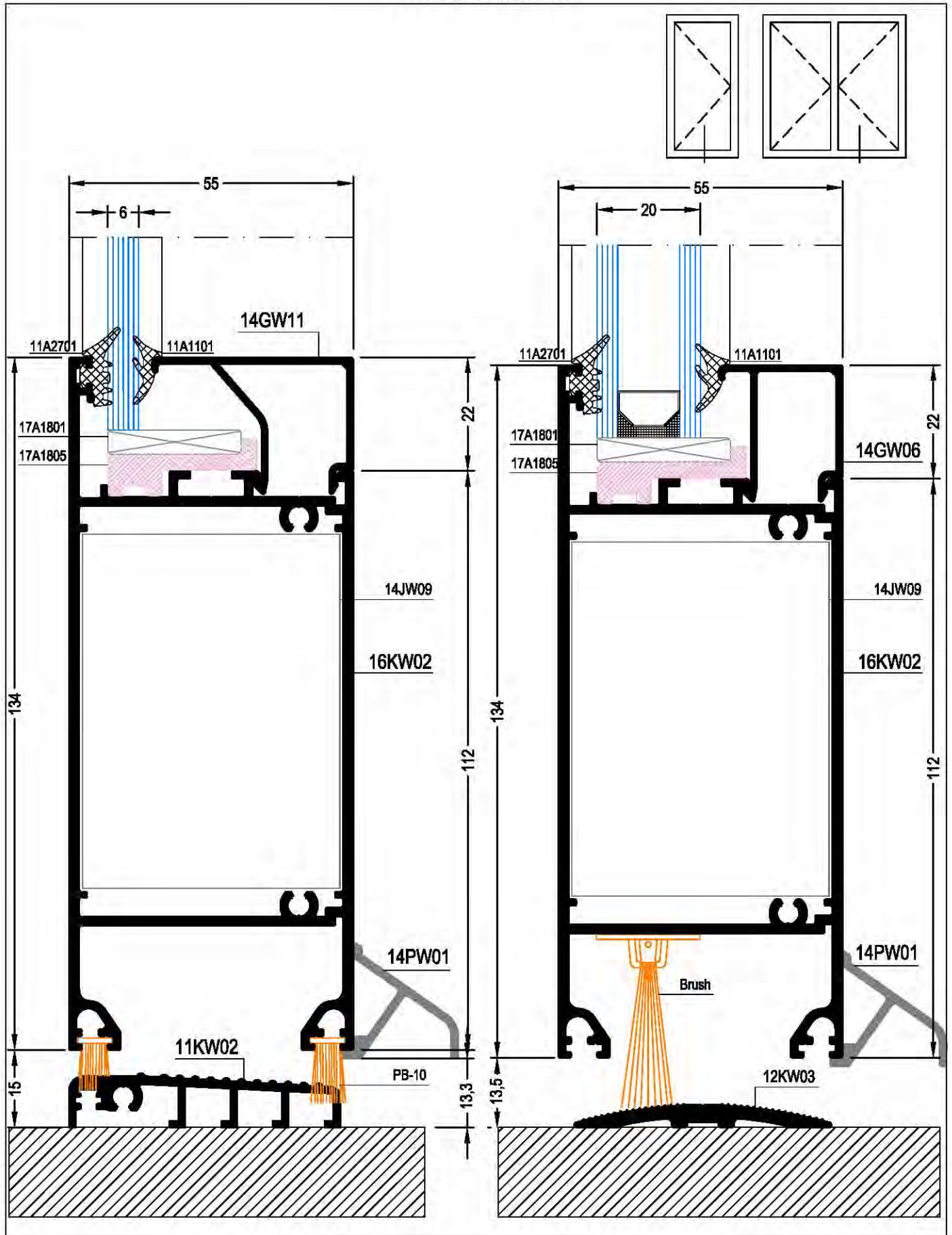

INSIDE OPENING DOOR

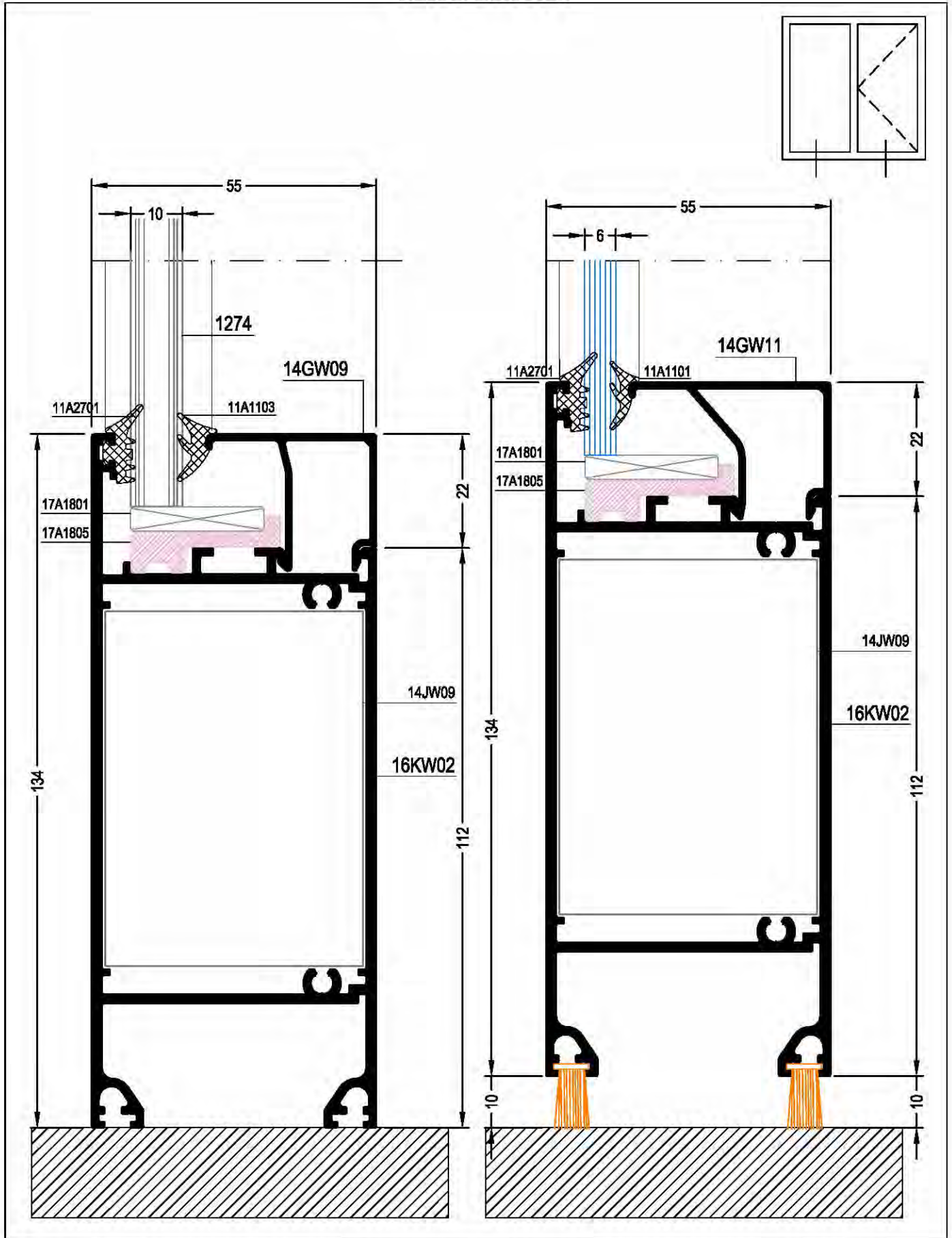

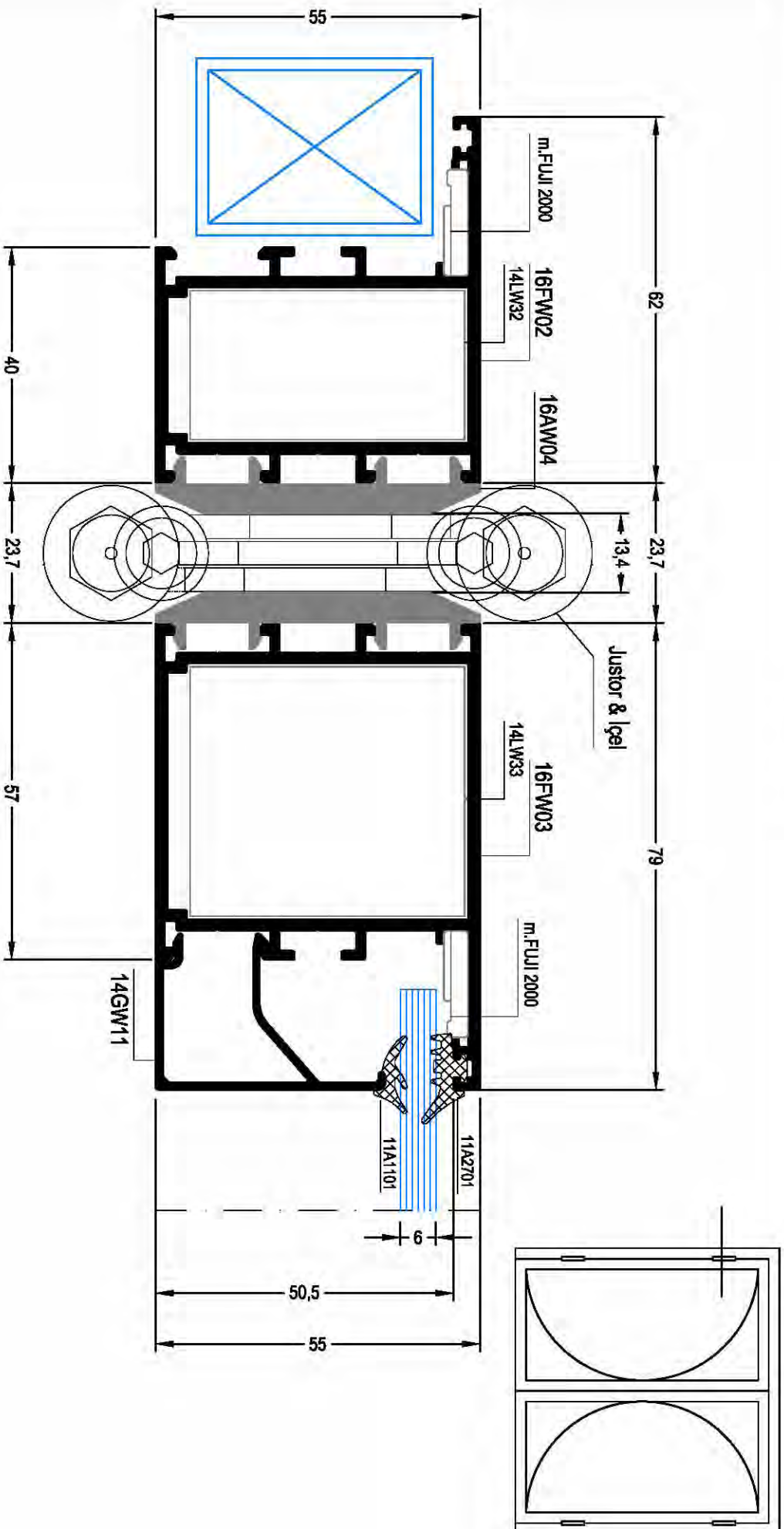

SYSTEM CASTLE 1655 W

DETAILS

SWINGING DOOR

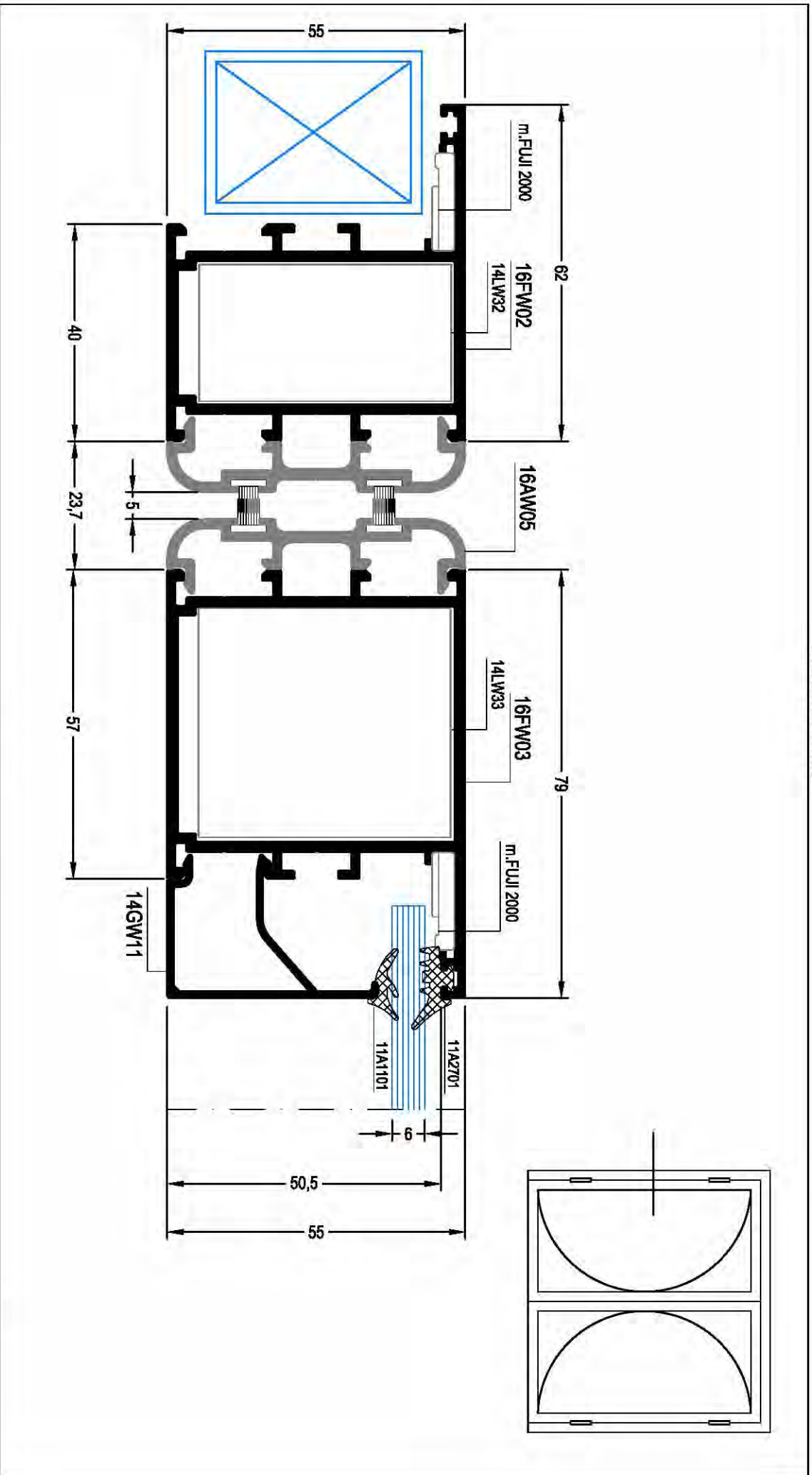

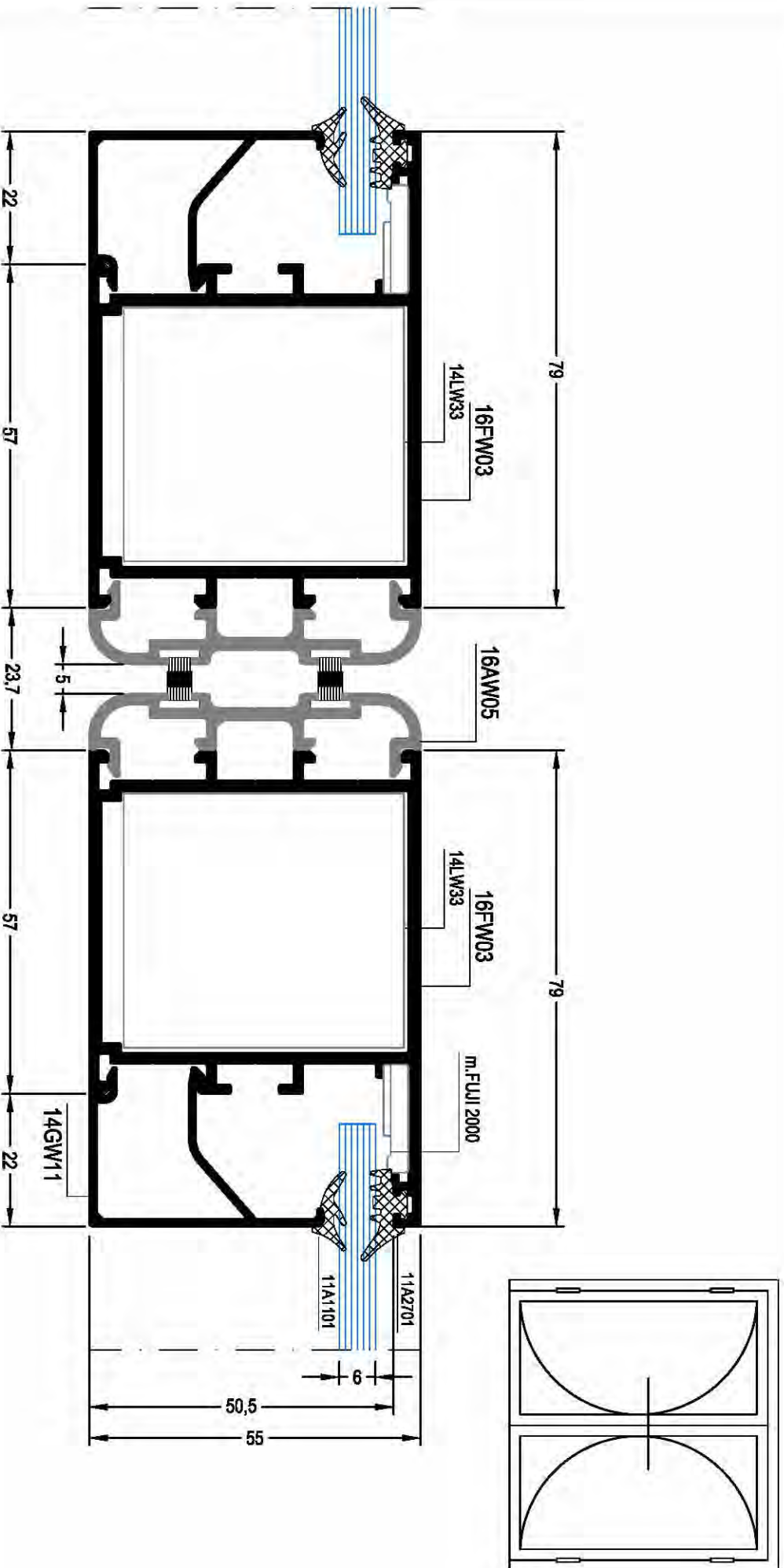

SWINGING DOOR

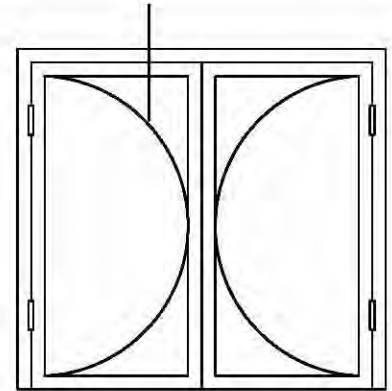
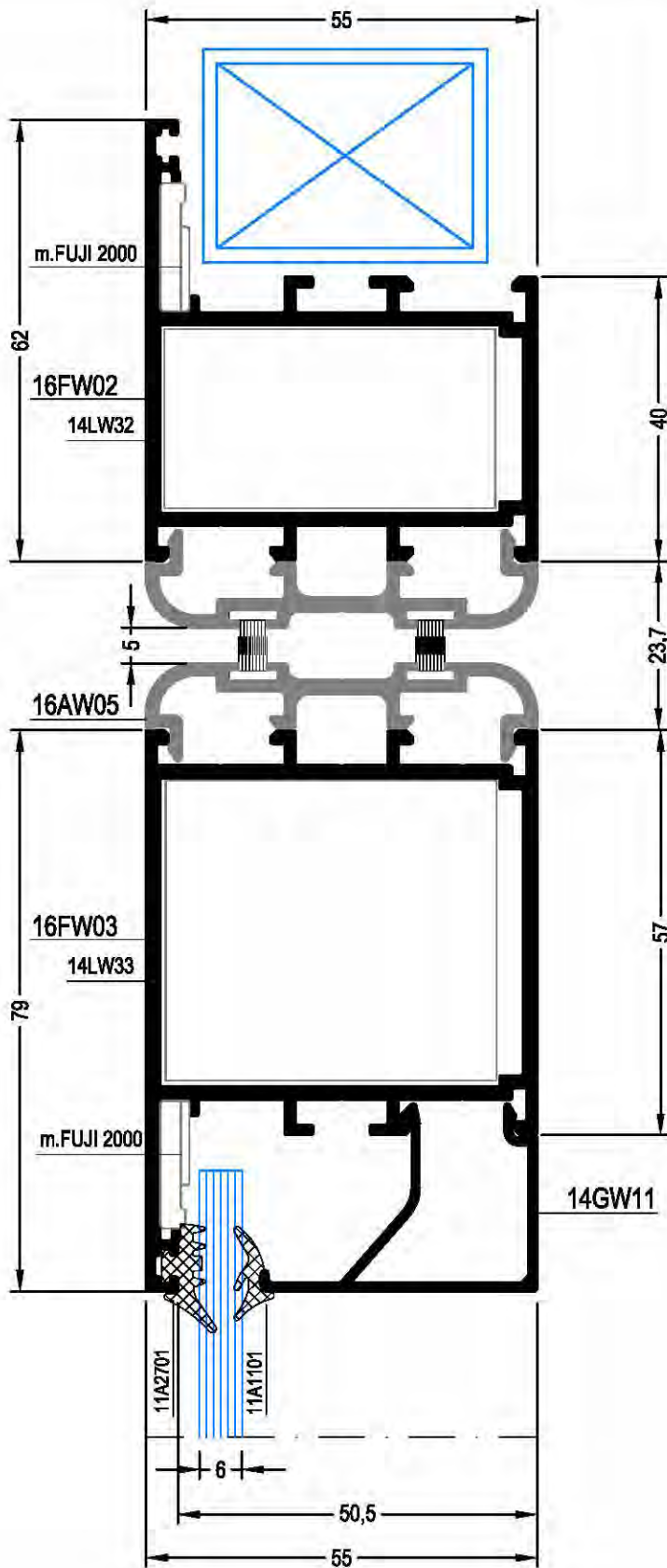

SWINGING DOOR

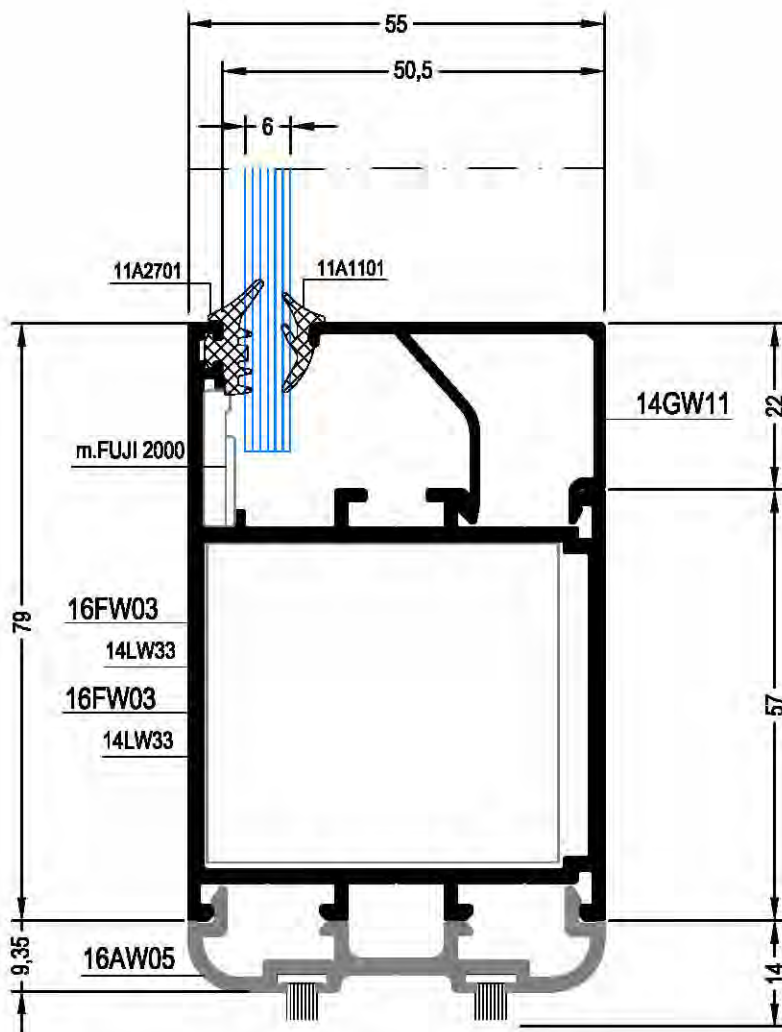
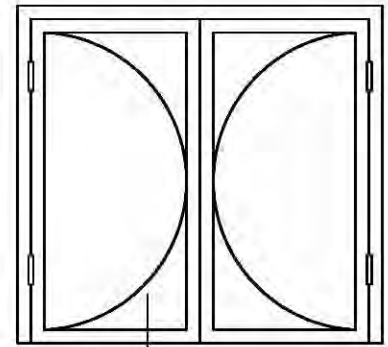

f - ASSEMBLY DRAWINGS

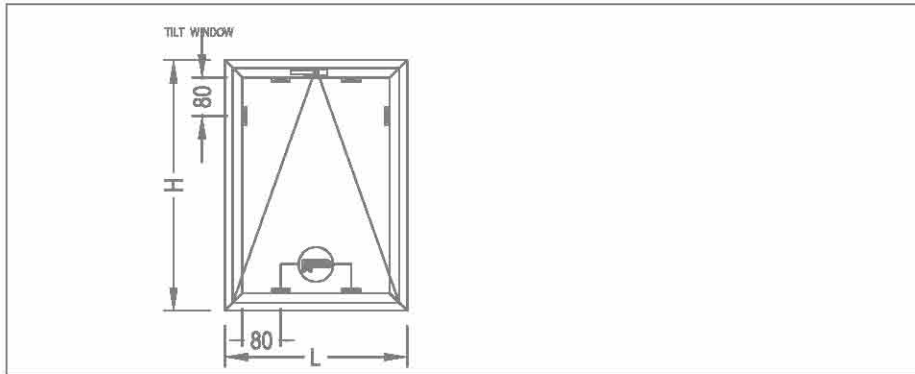



Glazing wedge for leveling



Glazing wedge for support

FIXED WINDOW

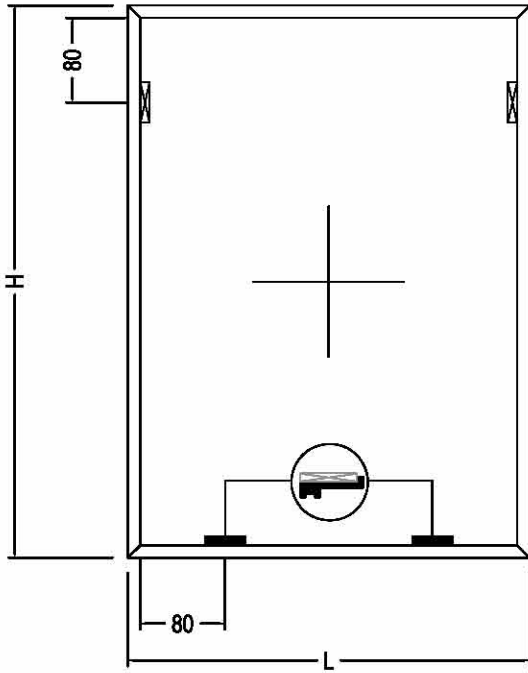

TURN WINDOW

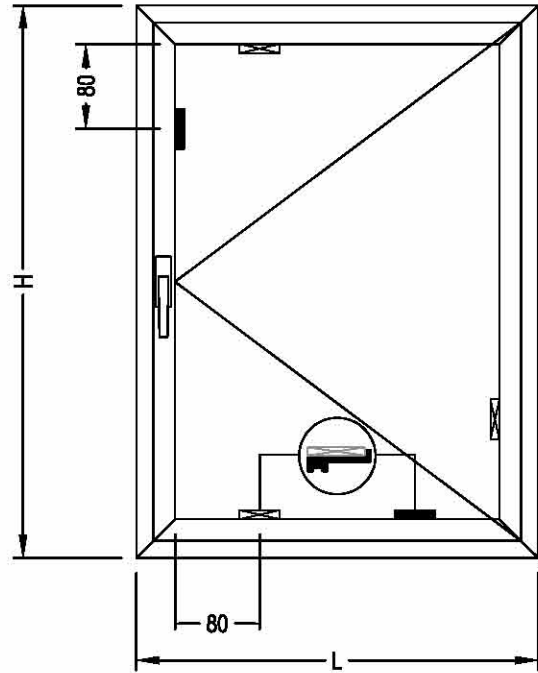

TURN AND TILT WINDOW

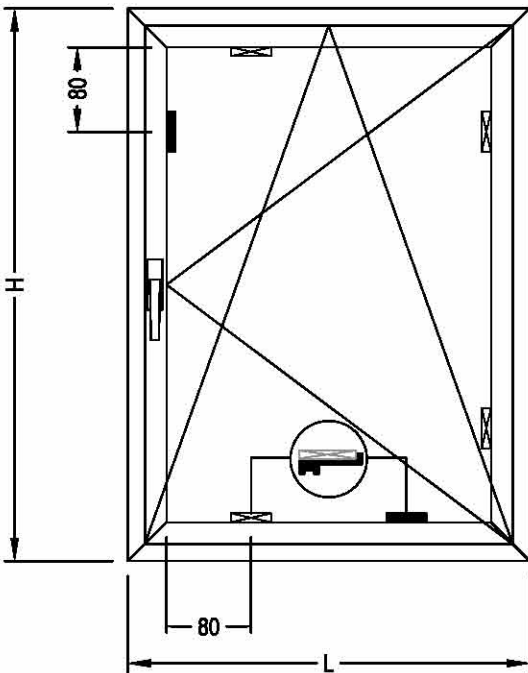

TILT WINDOW

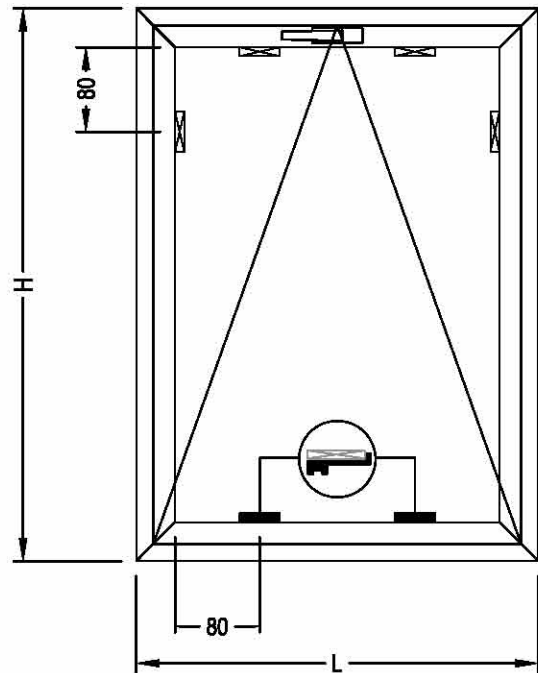

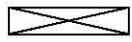

Glazing wedge for leveling



Glazing wedge for support

DOOR

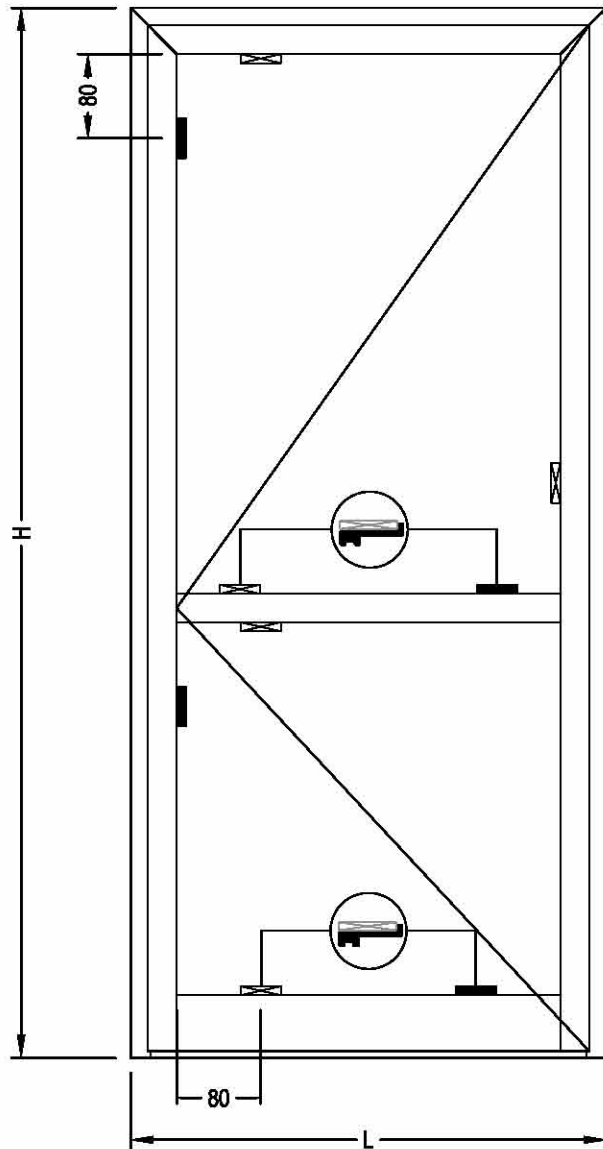



web : www.kurtogluas.com
E- mail : kurtoglu@kurtogluas.com

factory : Hacı Şeremet Mevkii TEM Otoyolu Çıkışı
Velimeşe/ ÇORLU / TEKİRDAĞ
Tel:(0282) 684 70 00 Fax:(0282) 684 70 01