

BR^L

Aluminium System

SYSTEM CASTLE

19'66 W+

ARCHITECTURAL
CATALOGUE





EDITION : 03 / 2006

BR^L
Aluminium System

SYSTEM CASTLE 19'66 W+

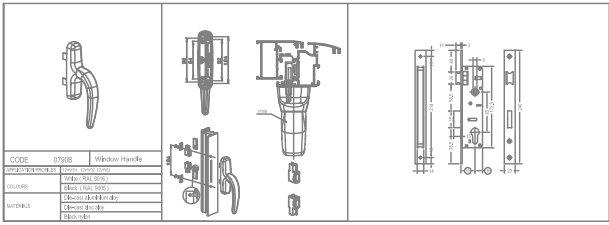
TECHNICAL INFORMATION

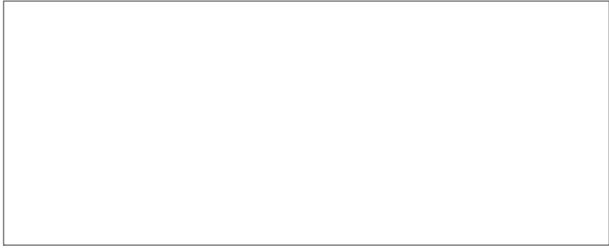
<p>a - TECHNICAL INFORMATION</p>	<table border="1"> <thead> <tr> <th rowspan="2">CATAL. PAGE</th> <th rowspan="2">NR</th> <th rowspan="2">PROFILE</th> <th rowspan="2">DESCRIPTION</th> <th rowspan="2">THEORETICAL WEIGHT</th> <th colspan="2">Statics</th> <th colspan="2">Surfaces</th> <th rowspan="2">L m</th> </tr> <tr> <th>Jxx (cm⁴)</th> <th>Jyy (cm⁴)</th> <th>Coating Surface (cm)</th> <th>Covering Surface (cm)</th> </tr> </thead> <tbody> <tr> <td> </td> <td> </td> <td> </td> <td> </td> <td> </td> <td> </td> <td> </td> <td> </td> <td> </td> <td> </td> </tr> </tbody> </table>	CATAL. PAGE	NR	PROFILE	DESCRIPTION	THEORETICAL WEIGHT	Statics		Surfaces		L m	Jxx (cm ⁴)	Jyy (cm ⁴)	Coating Surface (cm)	Covering Surface (cm)											<p>Page 001.a - 008.a</p>	
CATAL. PAGE	NR						PROFILE	DESCRIPTION	THEORETICAL WEIGHT	Statics		Surfaces		L m													
		Jxx (cm ⁴)	Jyy (cm ⁴)	Coating Surface (cm)	Covering Surface (cm)																						
<p>b - PROFILE</p>		<p>Page 001.b - 020.b</p>																									
<p>c - ACCESSORIES</p>	 <table border="1"> <tr> <td>CODE</td> <td>0708</td> <td>Window Handle</td> </tr> <tr> <td>DESCRIPTION</td> <td colspan="2">Maniglia in alluminio</td> </tr> <tr> <td>PRODOTTORE</td> <td colspan="2">BRU (SALIZADA)</td> </tr> <tr> <td>GLASSO</td> <td colspan="2">6mm, 5mm, 4mm</td> </tr> <tr> <td>PRODOTTORE</td> <td colspan="2">Cristallo di Friburgo</td> </tr> <tr> <td>MATERIALI</td> <td colspan="2">Alluminio 6063</td> </tr> <tr> <td>FINITURA</td> <td colspan="2">Anodizzato</td> </tr> </table>	CODE	0708	Window Handle	DESCRIPTION	Maniglia in alluminio		PRODOTTORE	BRU (SALIZADA)		GLASSO	6mm, 5mm, 4mm		PRODOTTORE	Cristallo di Friburgo		MATERIALI	Alluminio 6063		FINITURA	Anodizzato		<p>Page 001.c - 021.c</p>				
CODE	0708	Window Handle																									
DESCRIPTION	Maniglia in alluminio																										
PRODOTTORE	BRU (SALIZADA)																										
GLASSO	6mm, 5mm, 4mm																										
PRODOTTORE	Cristallo di Friburgo																										
MATERIALI	Alluminio 6063																										
FINITURA	Anodizzato																										
<p>d - GLAZING TABLE</p>	 <table border="1"> <thead> <tr> <th>A</th> <th>B</th> <th>C</th> <th>D</th> <th>E</th> </tr> <tr> <th>GLAZING BEAD</th> <th>GLAZING THICKNESS</th> <th>GLAZING GASKET INSIDE</th> <th>GLAZING GASKET OUTSIDE</th> <th>WEDGES</th> </tr> </thead> <tbody> <tr> <td>11GW12</td> <td>4 mm</td> <td>P1-4</td> <td>3 mm MO 68.3</td> <td>-----</td> </tr> <tr> <td>11GW12</td> <td>5 mm</td> <td>P1-3</td> <td>3 mm MO 68.3</td> <td>-----</td> </tr> <tr> <td>11GW11</td> <td>6 mm</td> <td>P1-5</td> <td>3 mm MO 68.3</td> <td>-----</td> </tr> </tbody> </table>	A	B	C	D	E	GLAZING BEAD	GLAZING THICKNESS	GLAZING GASKET INSIDE	GLAZING GASKET OUTSIDE	WEDGES	11GW12	4 mm	P1-4	3 mm MO 68.3	-----	11GW12	5 mm	P1-3	3 mm MO 68.3	-----	11GW11	6 mm	P1-5	3 mm MO 68.3	-----	<p>Page 001.d - 002.d</p>
A	B	C	D	E																							
GLAZING BEAD	GLAZING THICKNESS	GLAZING GASKET INSIDE	GLAZING GASKET OUTSIDE	WEDGES																							
11GW12	4 mm	P1-4	3 mm MO 68.3	-----																							
11GW12	5 mm	P1-3	3 mm MO 68.3	-----																							
11GW11	6 mm	P1-5	3 mm MO 68.3	-----																							
<p>e - DETAILS</p>		<p>Page 001.e - 036.e</p>																									
<p>f - CUTTING SIZES</p>																											
<p>g - APPLICATION DETAILS</p>																											

TECHNICAL INFORMATION

a - TECHNICAL INFORMATION

CATAL. PAGE	NR	PROFILE		DESCRIPTION	THEORETICAL WEIGHT kg/mt	Statics		Surfaces		L m ←→
						Jxx (cm ⁴)	Jyy (cm ⁴)	Coating Surface (cm)	Covering Surface (cm)	

* The weights are theoretical of presed profiles.

* When profiles are powder coated weight may increase by % 4 .

* Unless otherwise indicated , all dimensions in this catalogue are ±0.1 mm and weights may vary by % 4 .

TECHNICAL INFORMATION

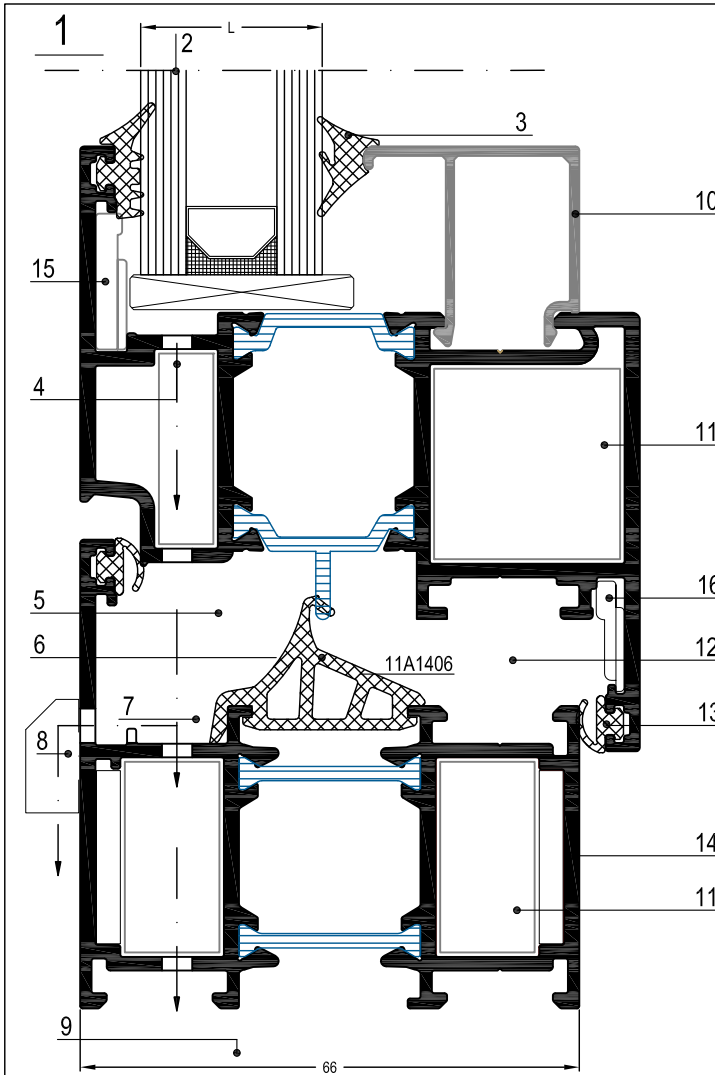

- 1 - Class 3 according to norm DIN4108
- 2 - Glazing : from 17 to 40 mm
- 3 - E.P.D.M. sealing Gasket
- 4 - Efficient drainage of the vent section
- 5 - Efficient chamber for pressure leveling which provides a better watertightness.
- 6 - Central sealing gasket for a better wind and watertightness.
- 7 - Proved drainage avoids infiltration of water under the central gasket.
- 8 - Direct front chamber drainage.
- 9 - Economic height : frame : 66 mm
vent : 74 mm
- 10- Different glazing beads from 15 mm to 36 mm
- 11 - Corner cleats with PRES
- 12 - Outer profile according to the European norm.
- 13- Acoustical gasket in E.P.D.M.
- 14- Different combinations of outer frames and vent sections.
- 15- Die cast corner joint for perfect corner
- 16- Pvc corner joint for perfect corner

EXTERIOR VIEW

INSIDE OPENING

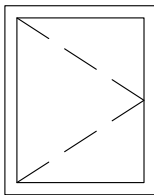

OUTSIDE OPENING

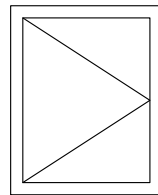

FIXED FRAME

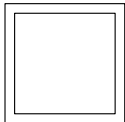

TURNING WINDOW

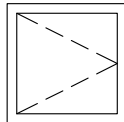

DOUBLE TURNING WINDOW

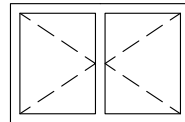

TURN & TILT WINDOW

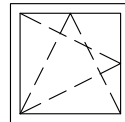

TURN & TILT
TURN WINDOW

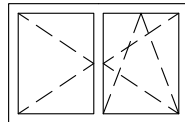

TILT WINDOW

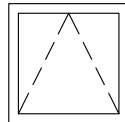

PROJECTING WINDOW

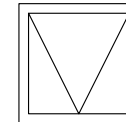

PIVOT WINDOW

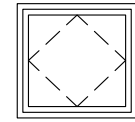

INSIDE OPENING DOOR

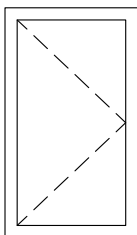

DOUBLE INSIDE OPENING DOOR

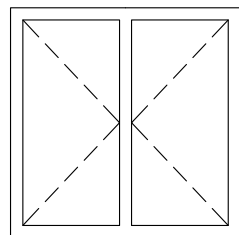

OUTSIDE OPENING DOOR

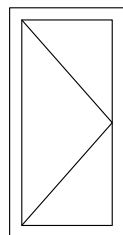

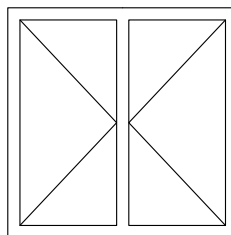

DOUBLE OUTSIDE OPENING DOOR

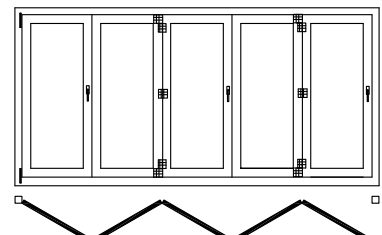

FOLDING DOOR

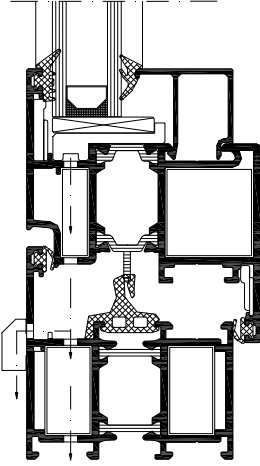

CONTENTS OF THE TENDER

<p>DESCRIPTIONS</p>	 
<p>*** CASTLE 17'60 W+ System insulated window and door systems.</p>	
<p>Construction Depth</p>	<p>* Window : Frame: 60 mm - Vent : 68 mm * Door : Frame: 60 mm - Vent :68 mm</p>
<p>Glazing</p>	<p>Glazing from 4 mm up to 40 mm with dry E.P.D.M. Gaskets. The choice of joints and glazing beads depends on the thickness of the glass.According to the tolerances of the glazing either a smaller or bigger joint and or glazing bead is used.</p>
<p>Special Characteristics</p>	<p>Window types : inside , tilt and turn , double casement , pivot window . Door types : inside door ,outside door ,double door , folding door. The structural profile walls have a nominal thickness of 1.6 to 2 mm. Curved and round windows possible. Compatible with curtain wall system. Special ventilation possibilities.</p>
<p>Connections</p>	<p>The corner connections between the profiles are applications die cast corner joint. The transoms are fixed with T-connections or with screw through the outer frame.</p>
<p>Gaskets</p>	<p>The opening windows have a central gasket an acoustical gasket and glazing gaskets in E.P.D.M. This gasket forms a barrier between the cold and the warm chambers and does not allow any cold air to pass through to the profile components on the inside. The central gasket ensures the window is wind and watertight over the complete surface. The acoustic gasket is uninterrupted.</p>
<p>Drainage</p>	<p>All window types must be equipped with a drainage system in the bottom profiles or the transoms.</p>
<p>Fitting and anchoring</p>	<p>The windows and doors are fitted level and at perfectly right angles.The aluminium constructions are fixed to the brickwork in such a way that shrinkage or expansion of the building have no influence on the aluminium constructions.</p>

GENERAL PRODUCT DESCRIPTION

Aluminium alloy

The aluminium profiles are made out of the alloy 6060 and 6063 .

The aluminium profiles have been extruded from the alloy AlMgSi 0.5 - F22 in according to the EN 12020 .

Tolerance are based on the standart EN 12020 .

Physical Properties

- 1. Density : 2.71 g / cm3
- 2. Elasticity module : 7000 kg / mm2
- 3. Resistance : 2650 kg / mm2
- 4. Melting point : 650 °C
- 5. Coefficient of expansion : 23x10 C
- 6. Thermal permeability : 0.48 cal / cm /s

Mechanical Properties

- 1. Rupture strength : 23.9 kg / mm2
- 2. Elasticity limit : 19 kg / mm2
- 3. Hardness : 25 Brinell

Surface Treatment

The profiles get a surface treatment as described further on. The colours of the profiles for the inside and outside are the same or different. The anodisation and enamel procedures are carried out under the responsibility of the systems supplier who offer

Electrostatic Powder Coating

The thermal break allows all surface treatments when compounded. The enamel construction version has the QUALICOAT label. On average, the coating thickness is minimally 60 micron. The architect can choose from the standart range of colour of the system su

Anodised Construction Version

The complete anodisation process takes place in accordance with the specifications of QUALANOD.

This procedure has to be applied to all exterior joinery situated in the following zones:

- *In industrial or highly polluted zones.
- *In city centres or along busy roads.
- *Along railroads.
- *In swimming pools , laboratories , industrial buildings , etc.

THERMAL TRANSMITTANCE

RMG (DIN 4108)

1 group	$k \leq 2.0 \text{ W / (m2K)}$
2.1 group	$2.0 < k \leq 2.8 \text{ W / (m2K)}$
*** 2.2 group	$2.8 < k \leq 3.5 \text{ W / (m2K)}$
2.3 group	$3.5 < k \leq 4.5 \text{ W / (m2K)}$
3 group ***	$k > 4.5 \text{ W / (m2K)}$

THERMAL TRANSMITTANCE ACCORDING TO EN ISO 10077-2

Theory

The thermal transmittance of a frame according to EN ISO 10077-2:

$$U_f = \frac{L_{2D} - U_p * l_p}{l_f} \quad \text{and} \quad L_{2D} = \frac{q_{L,tot}}{\Delta \theta}$$

- with:
- U_f : thermal transmittance of the window frame [W/m²K]
 - U_p : thermal transmittance of the flanking panel [W/m²K]
 - l_p : projected width of the flanking panel [m]
 - l_f : projected width of the window frame [m]
 - L_{2D} : two-dimensional coupling coefficient [W/mK]
 - $q_{L,tot}$: total heat flow through the window frame and the flanking panel [W/m]
 - $\Delta \theta$: temperature difference between inside (θ_i) and outside (θ_e) [K]

Calculation Item:

input data:	$q_{L,tot} = 16,250 \text{ W/m}$	$R_{se} = 0,04 \text{ m}^2\text{K/W}$
	$\theta_e = 0,0 \text{ }^\circ\text{C}$	$R_{sa} = 0,13 \text{ m}^2\text{K/W}$
	$\theta_i = 20,0 \text{ }^\circ\text{C}$	
	$d_p = 0,0200 \text{ m}$	
	$\lambda_p = 0,035 \text{ W/m}^\circ\text{K}$	
	$U_p = 1,349 \text{ W/m}^2\text{K}$	
	$l_p = 0,190 \text{ m}$	
		calculation results:
		$L_{2D} = 0,81 \text{ W/mK}$
	$l_f = 0,1750 \text{ m}$	$U_f = 3,18 \text{ W/m}^2\text{K}$

THERMAL TRANSMITTANCE

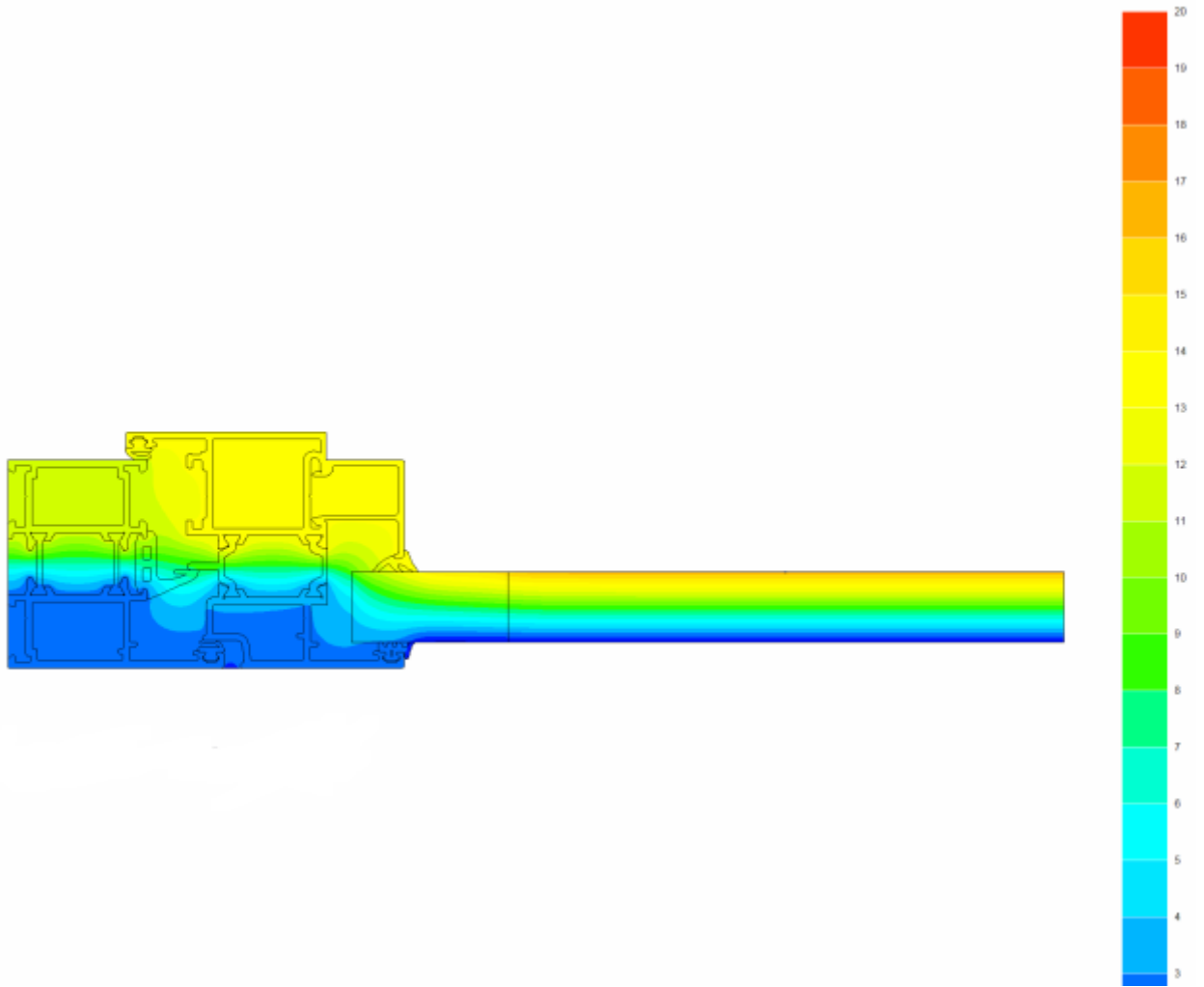

KURTOGLU BAKIR KURSUN SANAYI A.S.
BRL_17'60 Castle
Uf = 3,18

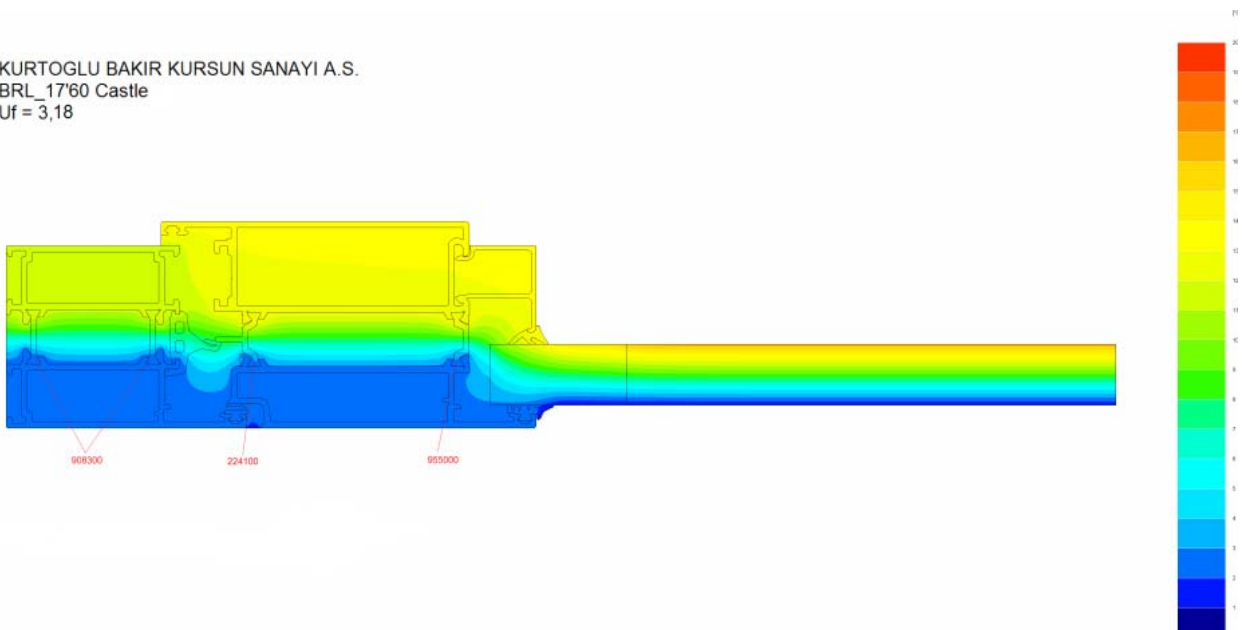

TEST REPORT

siskom Test Report
Sistem Kontrol Kualitas

Order : Order Nr. 78
Test Nr. : KURTOGLU ALM.2
Tested By : HUSEYIN SIMSEK

Date: 23.06.2006

Window sketch :

Dimensions (W x H) : 1.466 m x 1.256 m
Seal length: 6.420 m Sash area: 1.841 m² Window area: 1.173 m²

Description of Test Element

Window type : SYSTEM CASTLE 17'60 W+
Opening type : CIFT ACILIM-TILT AND TURN MECHANISM
Overall Dim. (W x H) : 1.466 x 1.256 m Area : 1.841 m²
Opening Vent (W x H) : 0.540 x 0.990 m Area : 0.535 m²
 : 0.580 x 1.100 m Area : 0.638 m²
 Total Area : 1.173 m²
Seal length : 6.420 m

Reference of profiles

Frame	:17 FW03	Sill Detail	:
Sash	:17 VW02	Transom	:
Mullion	:17 MW03	Glazing bead	:14 GW 19
Sealing	:11A 1404	Drip Bar	:14 PW 02
Hardware	:	Other	:
Material	:ALUMINIUM	Locking	:
Finish	:	Hinges	:

Glazing

Type	:TEMPER GLASS	Filling	:
Glazing	:6+12+4	Glas area	:
Glass Dim.	:22	Other	:

Roll shutter box

Classification (EN 12207;EN 12210; EN 12208)

Des: Airloss A4 Wind resistance W1 Water tightness RA2
Est : Airloss A4 Wind resistance W1C Water tightness RA2

Remarks:

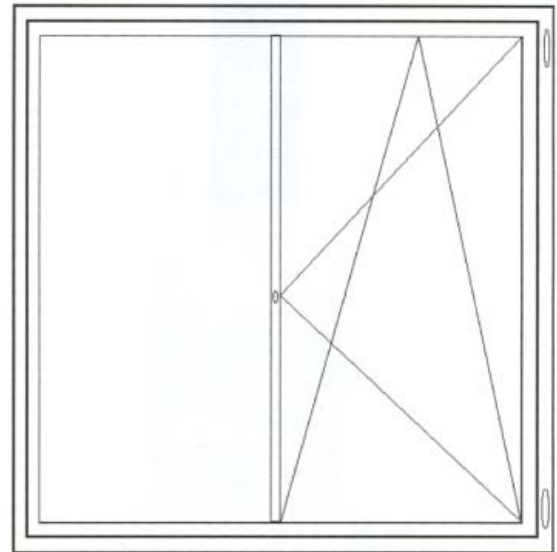

Milton Keynes, 23.06.2006 Tested By: 

Water Tighness EN 1027 : 2000

Spraying method A	Number of nozzles: 2	Vol. water: 240.0 Litre/Hour
Spraying angle: 24 Degree		: 4.0 Litre/Minute
Add. spraying pipe	Number of nozzles: 0	Vol. water: 0.0 Litre/Hour
(1.0 Litre/Nozzle)		: 0.0 Litre/Minute

Pres. Pa	Time	Remarks
0	00:15:00	OK
50	00:05:00	OK
100	00:05:00	OK
150	00:05:00	OK
200	00:05:00	OK
250	00:05:00	OK
300	00:05:00	OK
450	00:05:00	OK
600	00:05:00	OK

Water tighness class: RA9

Point of water ingress :

Probable cause of leakage :

TEST REPORT

siskom Test Report

System Control Market

Airloss EN 1026 : 2000

Airloss EN 1026:2000

Ambient temperature: 20 Celsius Ambient humidity : 75 % Ambient pressure: 10
 Total area : 1.841 m² Length of seal: 6.420 m

Pres. Pa	Total m3h	Window area		Seal length	
		m3/h/m ²	Class	m3/h/m	Class
50	3.18	1.73	A4	0.50	A3
100	4.68	2.54	A4	0.73	A4
150	6.17	3.35	A4	0.96	A4
200	7.47	4.05	A4	1.16	A4
250	8.58	4.66	A4	1.34	A4
300	9.72	5.28	A4	1.51	A4
450	12.01	6.96	A4	2.00	A4
600	16.92	9.19	A4	2.64	A3
-50	3.26	1.77	A4	0.51	A3
-100	4.54	2.47	A4	0.71	A4
-150	5.76	3.13	A4	0.90	A4
-200	6.81	3.70	A4	1.06	A4
-250	7.77	4.22	A4	1.21	A4
-300	8.58	4.66	A4	1.34	A4
-450	10.72	5.82	A4	1.67	A4
-600	12.32	6.69	A4	1.92	A4

Pressure: A4 Suction: A4

Pres. Pa	m3/h	m3/h/m ²	Class Area	Difference to 1.Test	m3/h/m	Class Seal Length	Difference to 1.Test
200	8.12	4.41	A4	0.010	1.26	A3	0.003
250	9.12	4.95	A4	0.026	1.42	A3	0.007
300	10.08	5.48	A4	0.049	1.57	A3	0.014
450	12.37	6.72	A4	0.018	1.93	A4	0.005
600	15.36	8.34	A4	0.043	2.39	A4	0.012
-50	3.90	2.12	A3	0.029	0.61	A3	0.008
-100	5.55	3.01	A3	0.029	0.86	A3	0.008
-150	6.89	3.74	A4	0.004	1.07	A3	0.001
-200	8.04	4.36	A4	0.004	1.25	A3	0.001
-250	9.07	4.93	A4	0.018	1.41	A3	0.005
-300	10.10	5.48	A4	0.017	1.57	A3	0.005
-450	12.20	6.63	A4	0.007	1.90	A4	0.002
-600	15.37	8.35	A4	0.033	2.39	A4	0.010

Classification after 2. air permeability: A3

Safety test:

P3 = -3000 Pa / 3000 Pa

Remarks suction :

Remarks pressure :

Class: WSC

TEST REPORT

ISTANBUL TECHNICAL UNIVERSITY
MACHINE FACULTYKurtoğlu Bakır Kurşun
Sanayii A.Ş.Pencere Sistemi Isı Geçiş
Katsayısı Tayini

Ds No : 06/3322

02.11.2006

Ek 4. Deney Protokolü

DENEY RAPORU

SICAK ODA YÖNTEMİNE GÖRE
MALZEMENİN TOPLAM ISI GEÇİŞ KATSAYISININ TAYİNİ

- Deney Yeri : İstanbul Teknik Üniversitesi, Makina Fakültesi,
Isı Tekniği Birimi, Isı Ölçmeleri Laboratuvarı.
- Deneyi İsteyen : Kurtoğlu Bakır Kurşun Sanayi A.Ş.
Hacı Şeremet Mevkii TEM Otoyolu Çıkışı Velimeşe Çorlu
- Denenen Malzeme : Deneyi isteyen tarafından getirilen ısı yalıtımlı BRL CASTLE 17'60W
kodlu pencere sistemi. Pencere sistemlerinde kullanılan profillerin
kesit resimleri Ek 1'de verilmiştir. Denenen numunenin
boyutları, Ek 2'deki şematik resimde verilmiştir.
- Deney Tesisi : Ek 3'de görülmektedir.
- Deneyde Ölçülen
Değerler : Ek 4'deki deney protokolünde verilmiştir.
- Hesap Yöntemi : Ölçülen değerler kullanılarak, denenen malzemenin toplam ısı geçiş
katsayısını hesaplama yöntemi, Ek 5'de açıklanmıştır.
- Deney Sonucu : K_C : çerçevenin toplam ısı geçiş katsayısı, $W/m^2 K$
 K_1 : ısıcamın toplam ısı geçiş katsayısı, $W/m^2 K$
 K_F : pencere sisteminin toplam ısı geçiş katsayısı, $W/m^2 K$
olmak üzere, yapılan deneyler sonucunda, aşağıdaki tabloda verilen, h
ve K_C değerleri elde edilmiştir. Burada, $K_1 = 3.0 W/m^2 K$ olarak
alınmıştır.

SICAK ODA SICAKLIĞI °C	SOĞUK ODA SICAKLIĞI °C	K_F $W/m^2 K$	K_C $W/m^2 K$
24.09	3.35	2.76	2.50

Q : Pencere sisteminden geçen ısı, W	57.14	
T_C : soğuk oda sıcaklığı, °C	3.35	
T_H : sıcak oda sıcaklığı, °C	24.09	
Pencerenin sıcak ve soğuk yüzeyleri arasındaki sıcaklık farkı, °C	T_1	9.1
	T_2	10.1
	T_3	10.4
	T_4	12.1
	T_5	10.0
	T_6	9.7
	T_7	8.9
	T_8	9.2
	T_9	8.6

Y.Doç.Dr. Erhan BÖKE

Yukarıdaki imzanın
Y.Doç.Dr. Erhan BÖKE'ye
ait olduğu tasdik olunur.

TECHNICAL INFORMATION

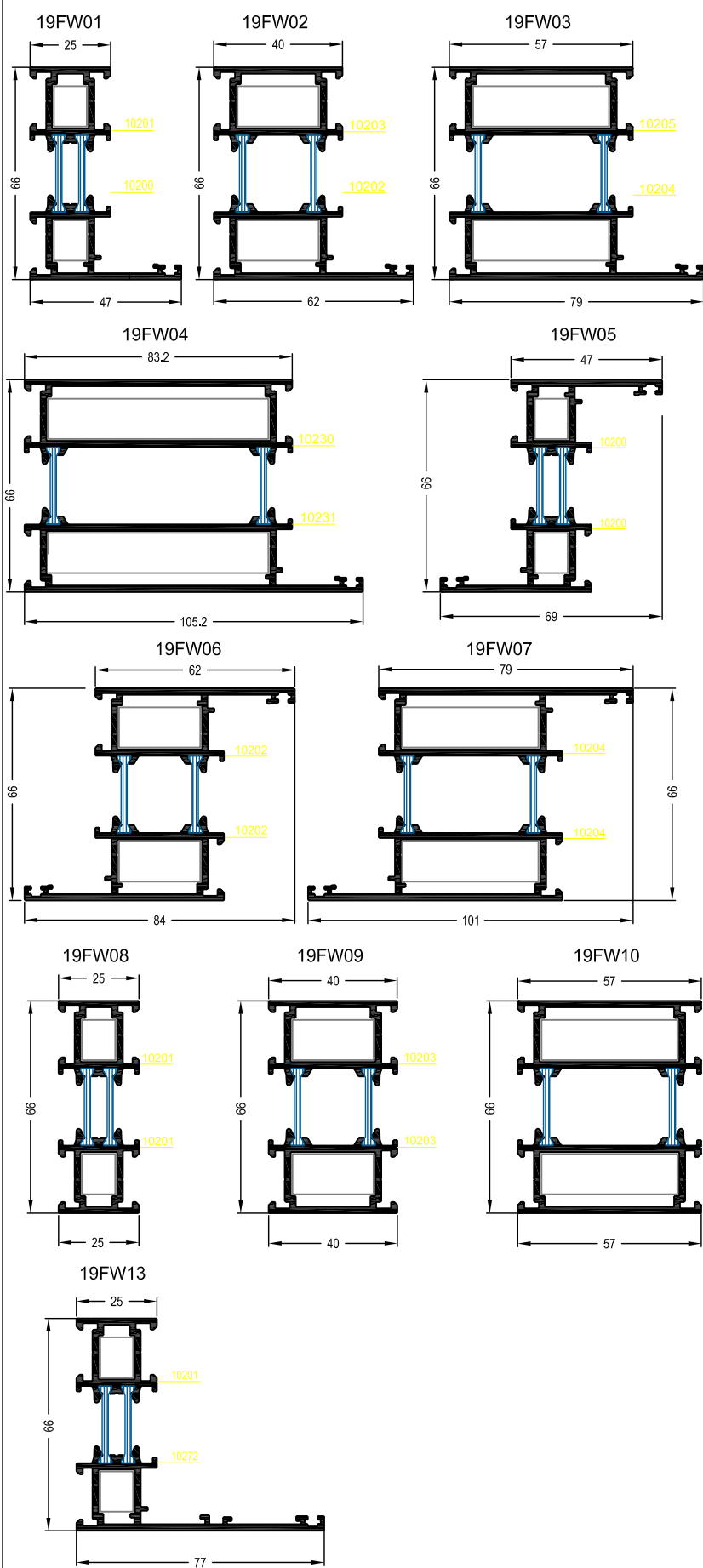

FRAMES

DESCRIPTION

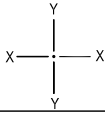

Pr.Nr.	THEORETICAL WEIGHT kg/mt.	Statics		Surfaces	
		Jxx(cm4)	Jyy(cm4)	Coating Surface (cm)	Covering Surface (cm)
17FW01	1.312	20.289	4.341	38.110	9.187
17FW02	1.646	26.826	12.746	44.762	12.187
17FW03	2.015	38.343	27.108	51.562	15.587
17FW04	2.583	87.901	40.529	62.042	20.827
17FW05	1.439	26.935	5.760	43.466	11.444
17FW06	1.773	35.448	14.291	49.940	14.444
17FW07	2.141	51.599	27.132	56.740	17.844
17FW08	1.186	15.808	2.111	33.110	6.930
17FW09	1.520	21.482	9.359	39.584	9.930
17FW10	1.888	27.888	26.051	46.384	13.330
17FW11	2.456	73.488	37.757	56.864	18.570
17FW13	1.505	32.923	10.718	45.686	12.394

TECHNICAL INFORMATION

FRAMES

19FW01: 25, 66, 47, 10201, 10200

19FW02: 40, 66, 62, 10203, 10202

19FW03: 57, 66, 79, 10205, 10204

19FW04: 83.2, 66, 105.2, 10230, 10231

19FW05: 47, 66, 69, 10200, 10200

19FW06: 62, 66, 84, 10202, 10202

19FW07: 79, 66, 101, 10204, 10204

19FW08: 25, 66, 25, 10201, 10201

19FW09: 40, 66, 40, 10203, 10203

19FW10: 57, 66, 57, 10205, 10205

19FW11: 41.6, 66, 83.2, 10230, 10230

19FW13: 25, 66, 77, 10201, 10272

DESCRIPTION

Pr.Nr.	THEORETICAL WEIGHT kg/mt	Statics		Surfaces	
		Jxx (cm4)	Jyy (cm4)	Coating Surface (cm)	Covering Surface (cm)
17FW01	1.312	20.289	4.341	38.110	9.187
17FW02	1.646	26.826	12.746	44.762	12.187
17FW03	2.015	38.343	27.108	51.562	15.587
17FW04	2.583	87.901	40.529	62.042	20.827
17FW05	1.439	26.935	5.760	43.466	11.444
17FW06	1.773	35.448	14.291	49.940	14.444
17FW07	2.141	51.599	27.132	56.740	17.844
17FW08	1.186	15.808	2.111	33.110	6.930
17FW09	1.520	21.482	9.359	39.584	9.930
17FW10	1.888	27.888	26.051	46.384	13.330
17FW11	2.456	73.488	37.757	56.864	18.570
17FW13	1.505	32.923	10.718	45.686	12.394

b - PROFILE

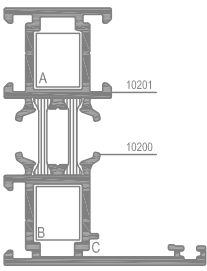
		FRAME PROFILE 25 / 47			
		PROFILE CODE 19FW01		THEORETICAL WEIGHT kg/m ² 1,364	
Jxx (cm ⁴)	Jyy (cm ⁴)	Coating Surface (cm)		Covering Surface (cm)	
---	---	10201	10200	10201	10200
THERMO BREAK		IMPORT (Polyamide)		908300 (18 mm I)	
		LOCAL (Pvc)		---	
CORNER CLEATS		A	B	C	D
PRESS CORNER				---	---
DE-CAST CORNER JOINT				M.f.ijl 2000	---
STEEL CORNER JOINT				---	---

* The weights are theoretical of presed profiles.

* When profiles are powder coated weight may increase by % 4 .

* Unless otherwise indicated , all dimensions in this catalogue are ± 0.1 mm and weights may vary by % 4 .

FRAMES

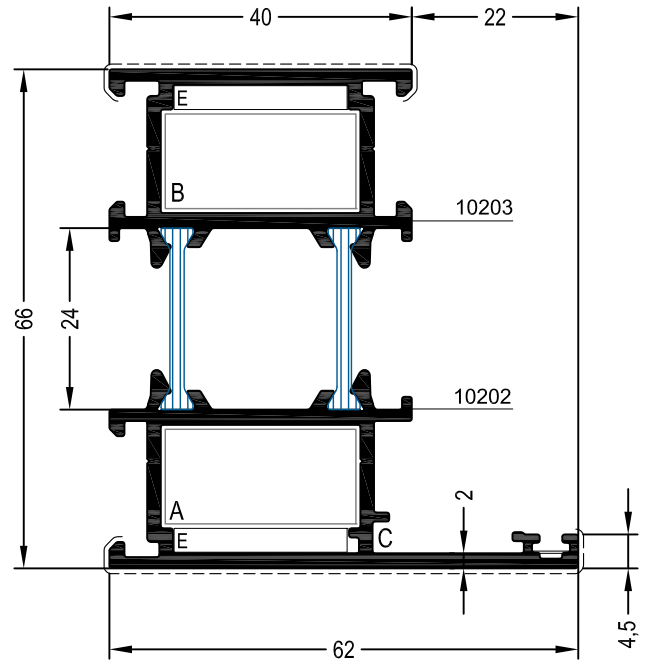
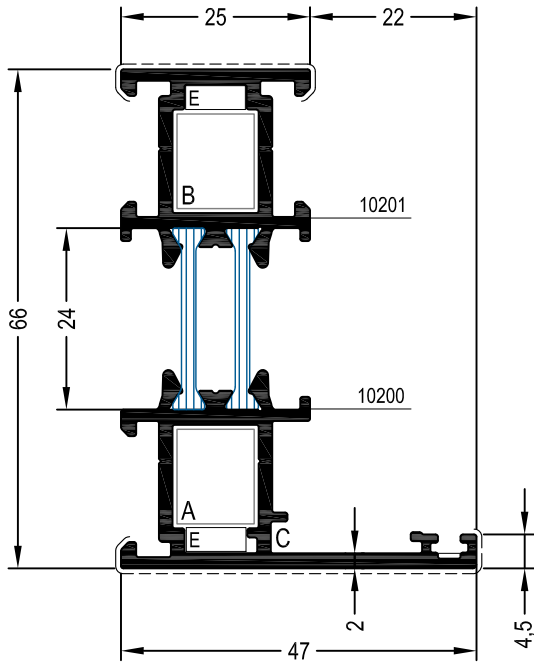



FRAME PROFILE 25 / 47



FRAME PROFILE 40 / 62



PROFILE CODE		19FW01		THEORETICAL WEIGHT kg/mt		1.364		PROFILE CODE		19FW02		THEORETICAL WEIGHT kg/mt		1.695	
Jxx (cm ⁴)	Jyy (cm ⁴)	Covering Surface (cm)				Jxx (cm ⁴)	Jyy (cm ⁴)	Covering Surface (cm)							
		10201	10200				10203	10202							
20.289	4.341	3.465	5.722		26.826	12.746	4.965	7.222							
THERMO BREAK		LOCAL (Pvc)				THERMO BREAK				LOCAL (Pvc)					
CORNER CLEATS		A	B	C	D	E	CORNER CLEATS		A	B	C	D	E		
PRESS CORNER		14LW14	14LW14	----	----	----	PRESS CORNER		14LW32	14LW32	----	----	----		
DIE-CAST CORNER JOINT		----	----	M.fuji 2000	----	----	DIE-CAST CORNER JOINT		----	----	M.fuji 2000	----	----		
P.V.C. CORNER JOINT		----	----	----	----	P.V.C.	P.V.C. CORNER JOINT		----	----	----	----	P.V.C.		

FRAMES

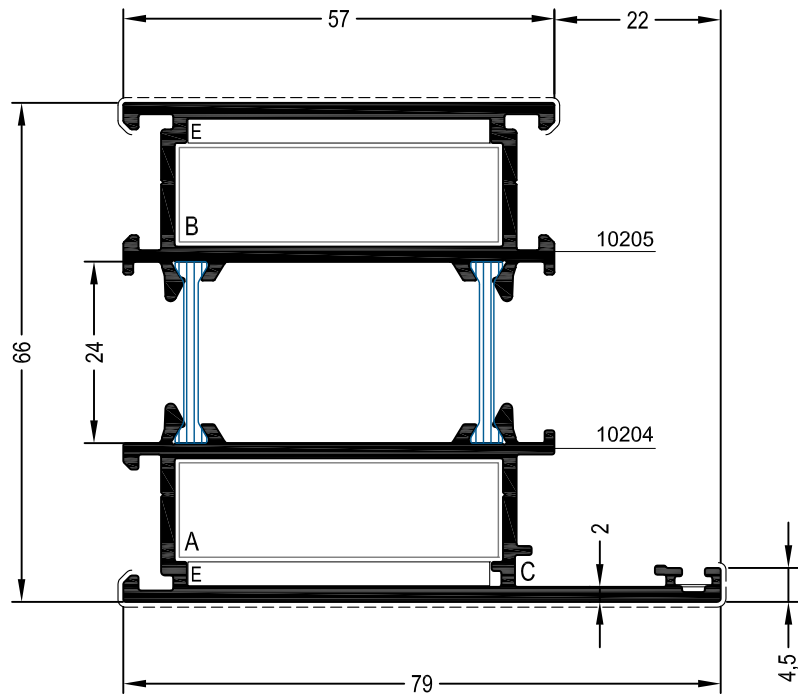

FRAME PROFILE		57 / 79				
PROFILE CODE		19FW03		THEORETICAL WEIGHT kg/mt		
				2.064		
Jxx (cm ⁴)	Jyy (cm ⁴)	Covering Surface (cm)				
		10205	10204			
38.343	27.108	6.665	8.922			
THERMO BREAK		LOCAL (Pvc)		-----		
CORNER CLEATS		A	B	C	D	E
PRESS CORNER		14LW33	14LW33	----	----	----
DIE-CAST CORNER JOINT		----	----	M.fuji 2000	----	----
P.V.C. CORNER JOINT		----	----	----	----	P.V.C.

FRAMES

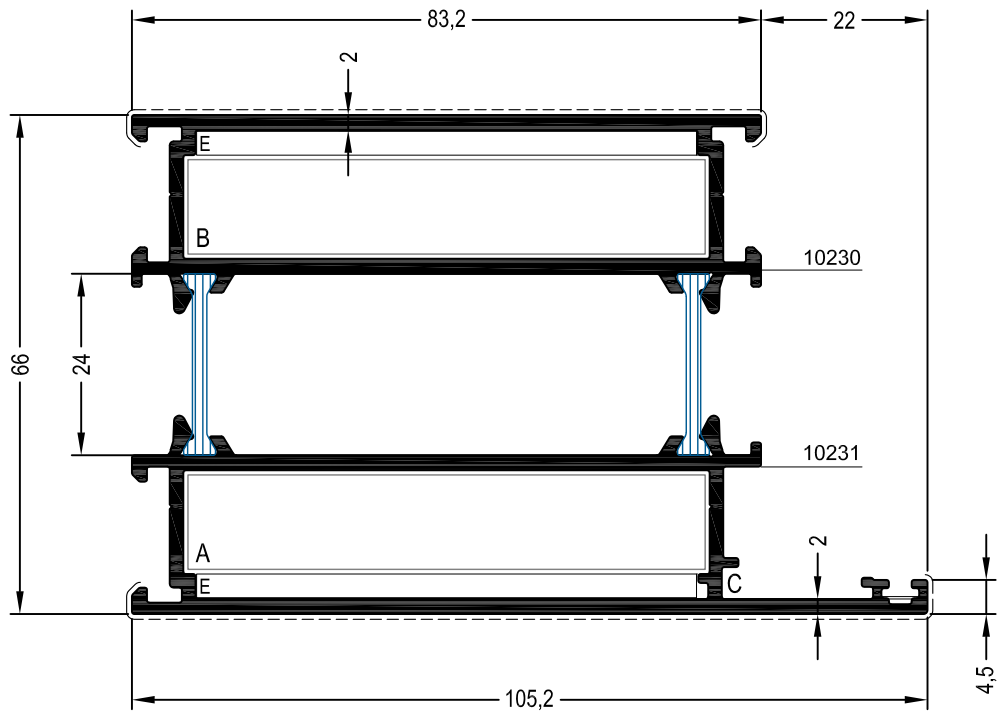

FRAME PROFILE		83.2 / 105.2				
PROFILE CODE		19FW04		THEORETICAL WEIGHT kg/mt		
				2.630		
Jxx (cm ⁴)	Jyy (cm ⁴)	Covering Surface (cm)				
		10230	10231			
87.901	40.529	9.285	11.542			
THERMO BREAK		LOCAL (Pvc)				

CORNER CLEATS		A	B	C	D	E
PRESS CORNER		14LW34	14LW34	-----	-----	-----
DIE-CAST CORNER JOINT		-----	-----	M.fuji 2000	-----	-----
P.V.C. CORNER JOINT		-----	-----	-----	-----	P.V.C.

FRAMES

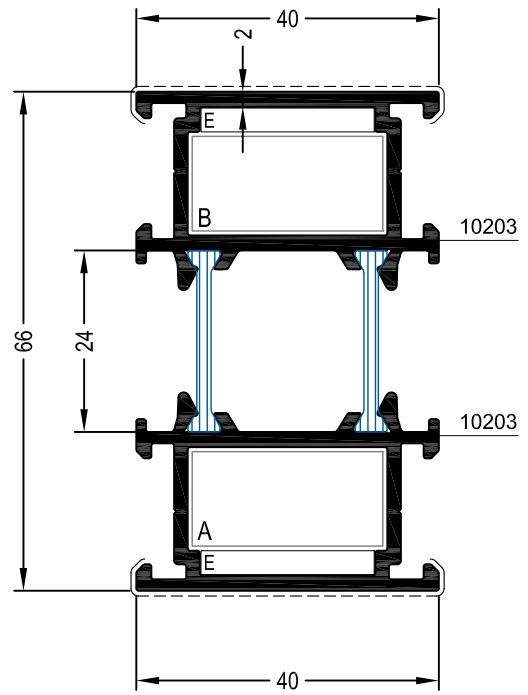
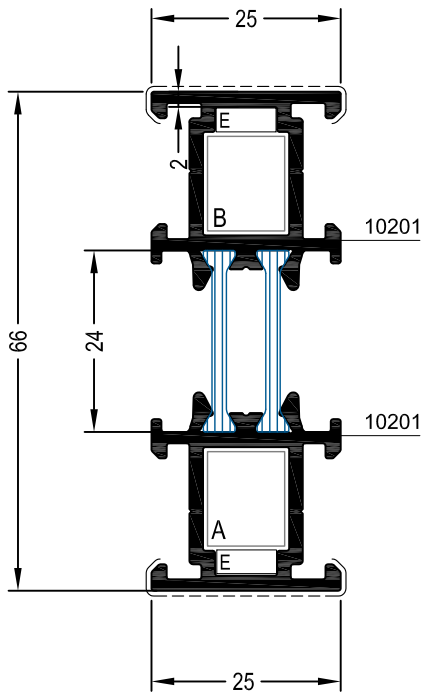

FRAME PROFILE 25 / 25



FRAME PROFILE 40 / 40

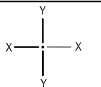

PROFILE CODE

19FW08

THEORETICAL WEIGHT kg/mt
1.237

PROFILE CODE

19FW09

THEORETICAL WEIGHT kg/mt
1.571

Jxx (cm4)

Jyy (cm4)

Covering Surface (cm)

10201

10201

15.808

2.111

3.465

3.465

THERMO BREAK

LOCAL (Pvc)

Jxx (cm4)

Jyy (cm4)

Covering Surface (cm)

10203

10203

21.482

9.359

4.965

4.965

THERMO BREAK

LOCAL (Pvc)

T JUNCTION



A

B

C

14JW04

14JW04

CORNER CLEATS



A

B

C

14LW14

14LW14

T JUNCTION



A

B

C

14JW04

14JW04

CORNER CLEATS



A

B

C

14LW32

14LW32

FRAMES

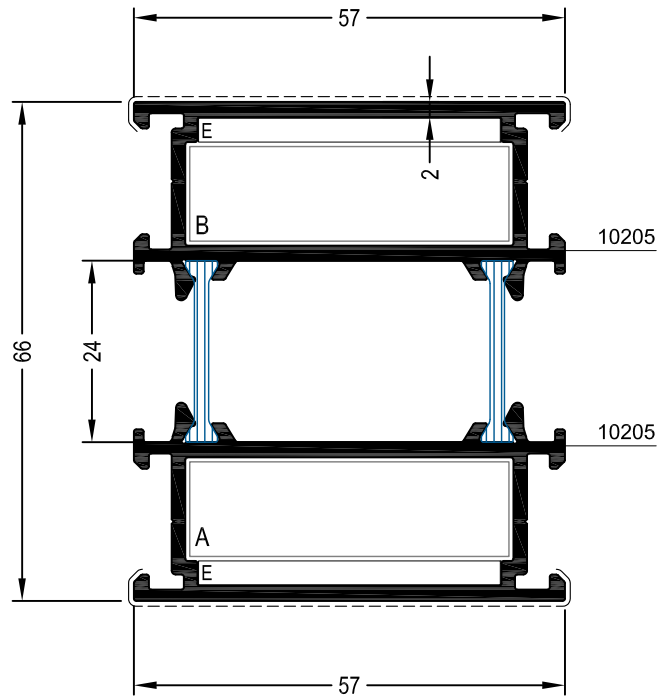

FRAME PROFILE		57 / 57			
PROFILE CODE		19FW10		THEORETICAL WEIGHT kg/mt	
				1.940	
Jxx (cm ⁴)	Jyy (cm ⁴)	Covering Surface (cm)			
		10205		10205	
27.888	26.051	6.665		6.665	
THERMO BREAK					
		LOCAL (Pvc)		----	
T JUNCTION		A	B	C	
		14JW04	14JW04	----	
CORNER CLEATS		A	B	C	
		14LW33	14LW33	----	

FRAMES

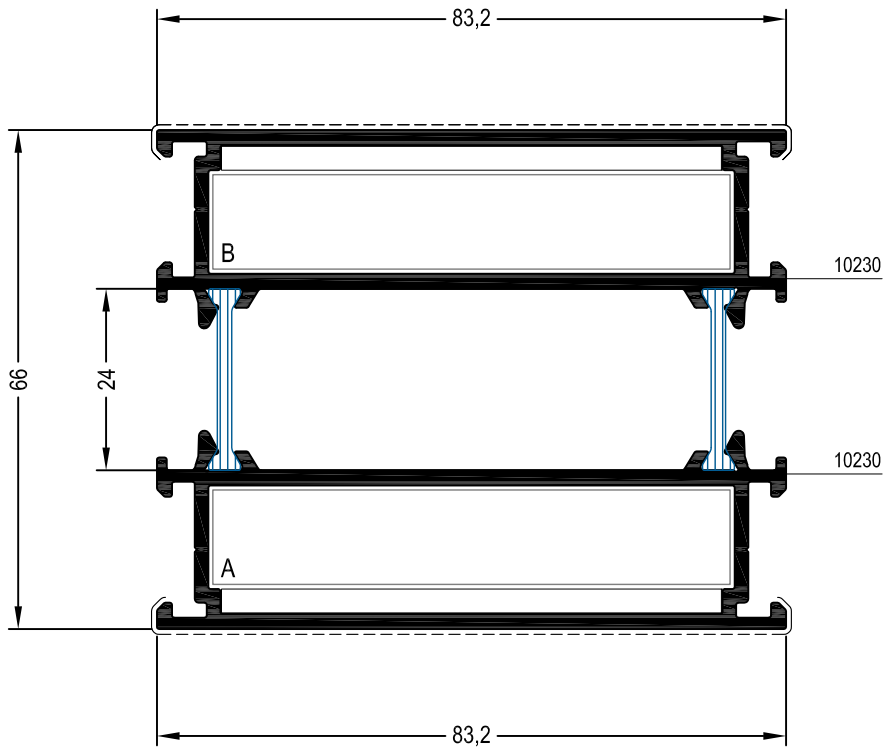

FRAME PROFILE		83.2 / 83.2			
PROFILE CODE		19FW11		THEORETICAL WEIGHT kg/mt	
				2.504	
Jxx (cm ⁴)	Jyy (cm ⁴)	Covering Surface (cm)			
		10230	10230		
73.488	37.757	9.285	9.285		
THERMO BREAK		LOCAL (Pvc)		----	
T JUNCTION		A	B	C	
		14JW04	14JW04	----	
CORNER CLEATS		A	B	C	
		14LW34	14LW34	----	

FRAMES

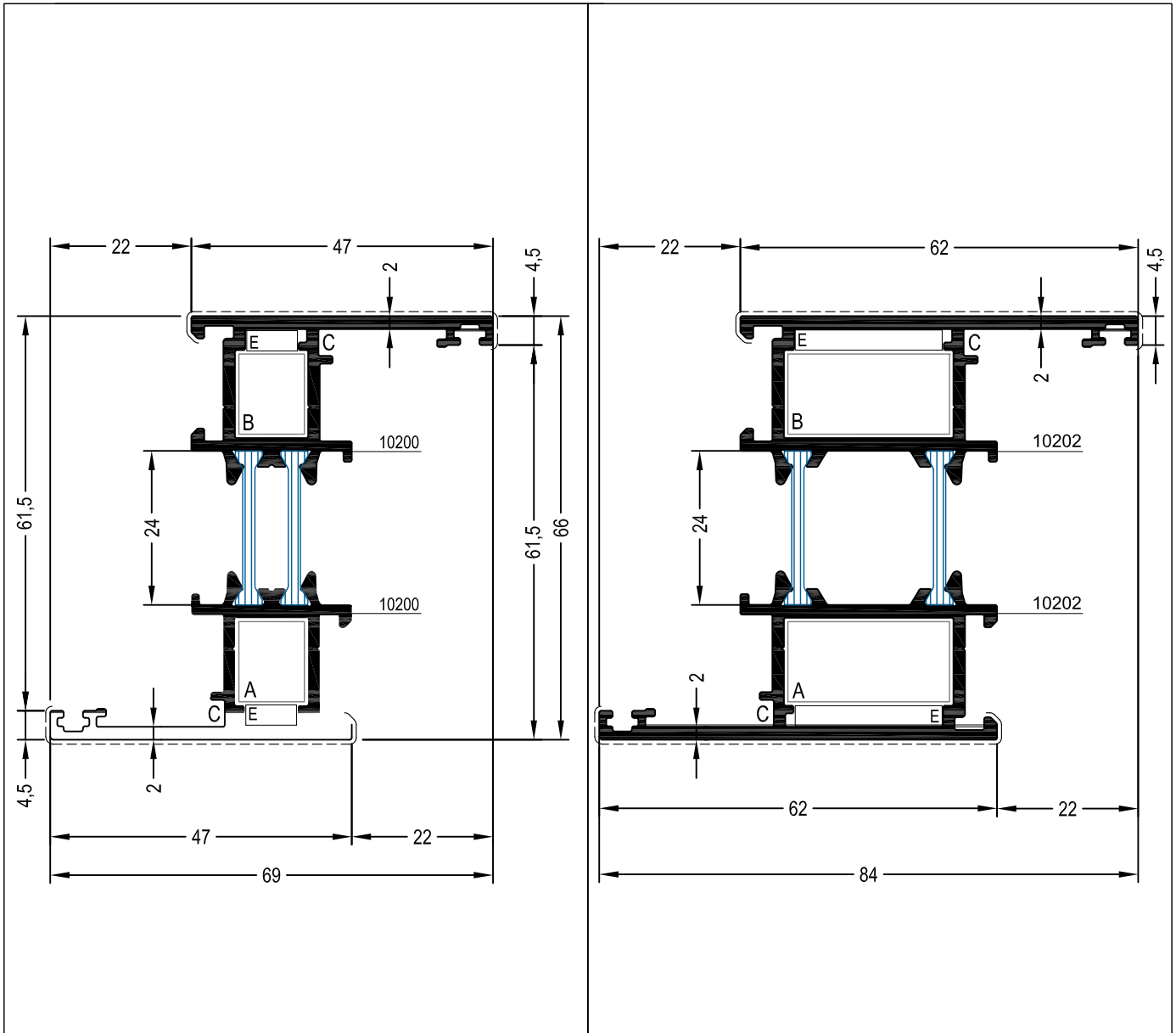

FRAME PROFILE 47 / 47					FRAME PROFILE 62 / 62								
PROFILE CODE		19FW05			THEORETICAL WEIGHT kg/mt		1.490						
Jxx (cm ⁴)	Jyy (cm ⁴)	Covering Surface (cm)			Jxx (cm ⁴)	Jyy (cm ⁴)	Covering Surface (cm)						
26.935	5.760	10200	10200	10200	35.448	14.291	10202	10202	10202				
		5.722		5.722			7.222		7.222				
THERMO BREAK		LOCAL (Pvc)			THERMO BREAK			LOCAL (Pvc)					
		----					----						
CORNER CLEATS		A	B	C	D	E	CORNER CLEATS		A	B	C	D	E
PRESS CORNER		14LW14	14LW14	----	----	----	PRESS CORNER		14LW32	14LW32	----	----	----
DIE-CAST CORNER JOINT		----	----	M.fuji 2000	----	----	DIE-CAST CORNER JOINT		----	----	M.fuji 2000	----	----
P.V.C. CORNER JOINT		----	----	----	----	P.V.C.	P.V.C. CORNER JOINT		----	----	----	----	P.V.C.

FRAMES

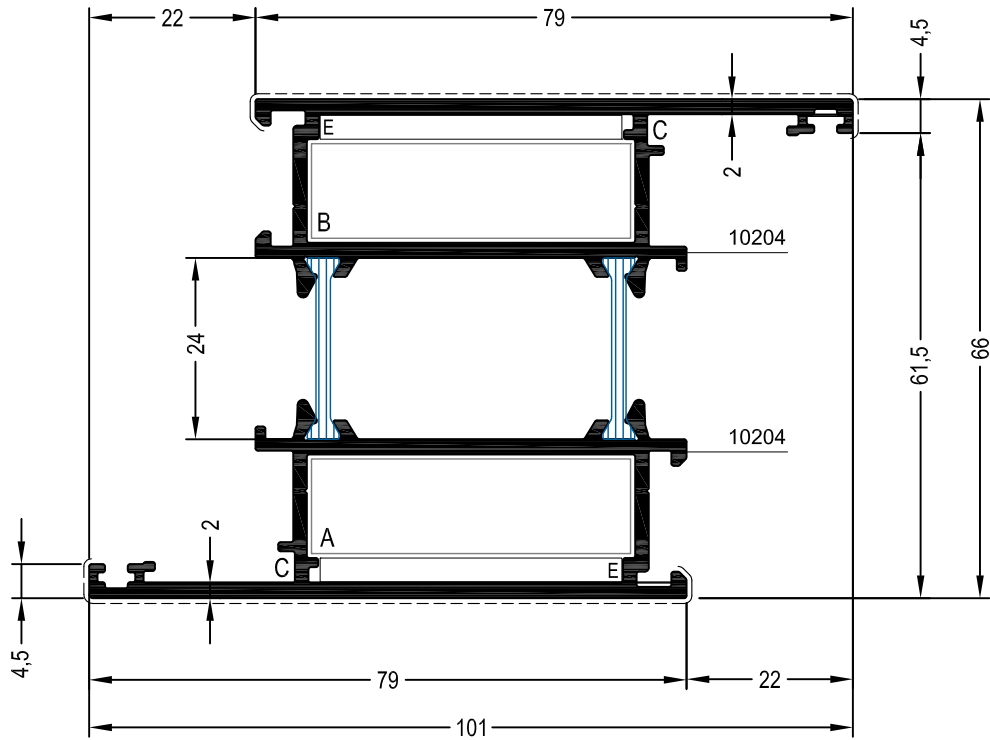

FRAME PROFILE		79 / 79				
PROFILE CODE		19FW07		THEORETICAL WEIGHT kg/mt		
				2.188		
Jxx (cm ⁴)	Jyy (cm ⁴)	Covering Surface (cm)				
		10204		10204		
51.599	27.132	8.922		8.922		
THERMO BREAK		LOCAL (Pvc) -----				
CORNER CLEATS		A	B	C	D	E
PRESS CORNER		14LW33	14LW33	-----	-----	-----
DIE-CAST CORNER JOINT		-----	-----	M.fuji 2000	-----	-----
P.V.C. CORNER JOINT		-----	-----	-----	-----	P.V.C.

FRAMES

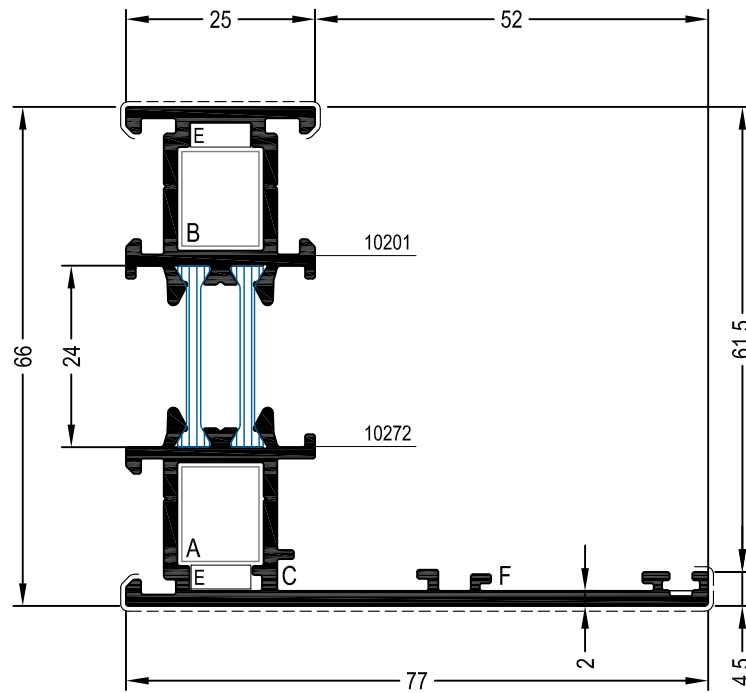

FRAME PROFILE		25 / 77					
PROFILE CODE		19FW13		THEORETICAL WEIGHT kg/mt			
				1.555			
Jxx (cm ⁴)	Jyy (cm ⁴)	Covering Surface (cm)					
		10201	10272				
32.923	10.718	3.465	8.929				
THERMO BREAK		LOCAL (Pvc)		----			
CORNER CLEATS		A	B	C	D	E	F
PRESS CORNER		14LW14	14LW14	----	----	----	----
DIE-CAST CORNER JOINT		----	----	M.fuji 2000	----	----	STEEL
P.V.C. CORNER JOINT		----	----	----	----	P.V.C.	----

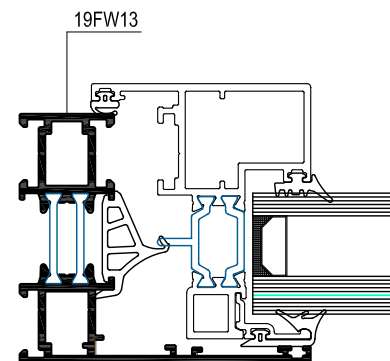

VENTS

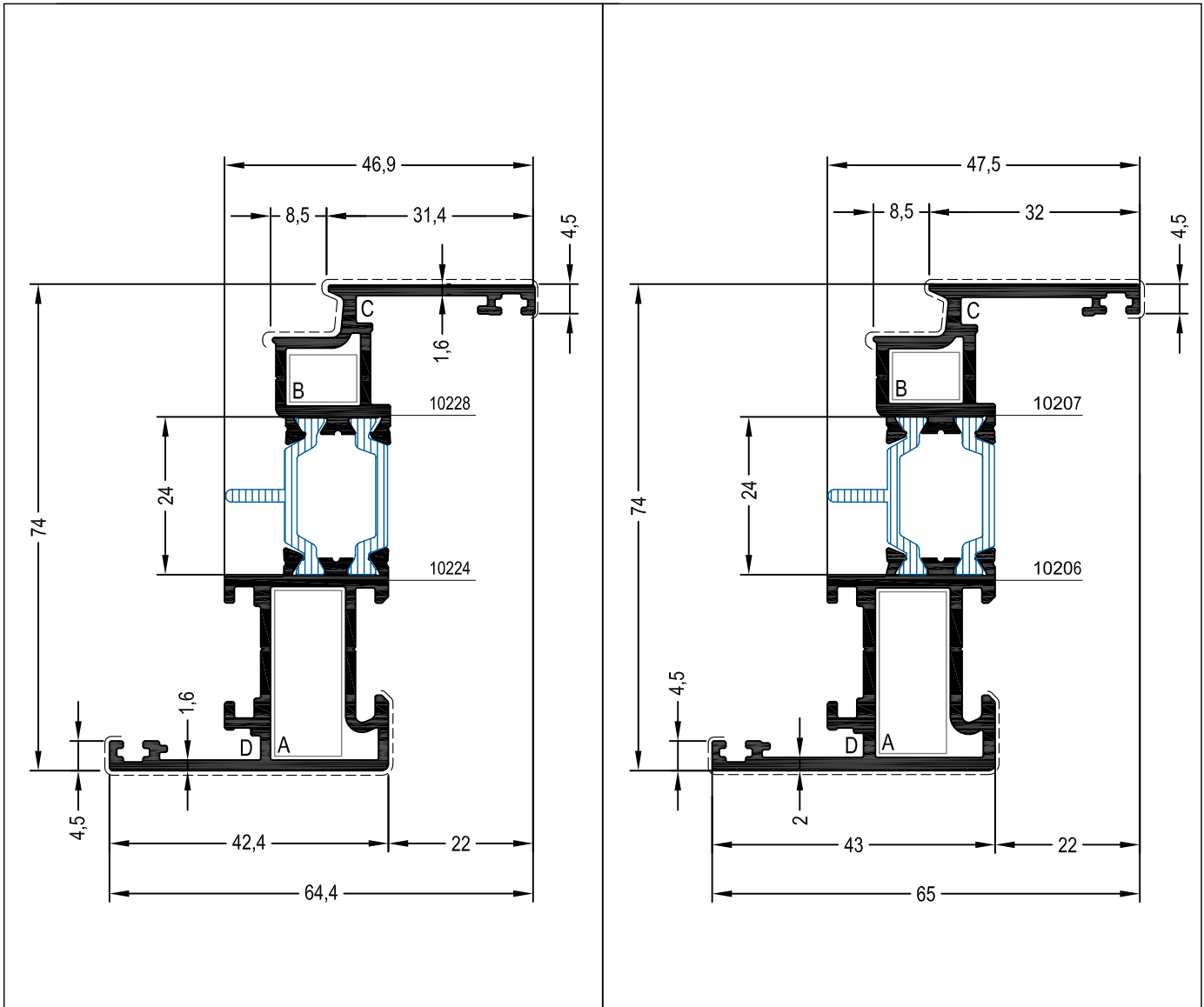

VENT PROFILE 42.4				VENT PROFILE 43					
PROFILE CODE		19VW07		PROFILE CODE		19VW01			
Jxx (cm ⁴)		Jyy (cm ⁴)		Jxx (cm ⁴)		Jyy (cm ⁴)			
29.074		4.753		32.907		5.386			
THEORETICAL WEIGHT kg/mt		1.398		THEORETICAL WEIGHT kg/mt		1.547			
Covering Surface (cm)		Covering Surface (cm)		Covering Surface (cm)		Covering Surface (cm)			
10228		10224		10207		10206			
5.999		6.029		6.156		6.089			
THERMO BREAK		LOCAL (Pvc)		THERMO BREAK		LOCAL (Pvc)			
CORNER CLEATS		A	B	C	D	A	B	C	D
PRESS CORNER		14LW14	14LW14	----	----	14LW14	14LW14	----	----
DIE-CAST CORNER JOINT		----	----	M.fuji 2000	----	----	----	M.fuji 2000	----
P.V.C. CORNER JOINT		----	----	----	MO 20	----	----	----	MO 20

VENTS

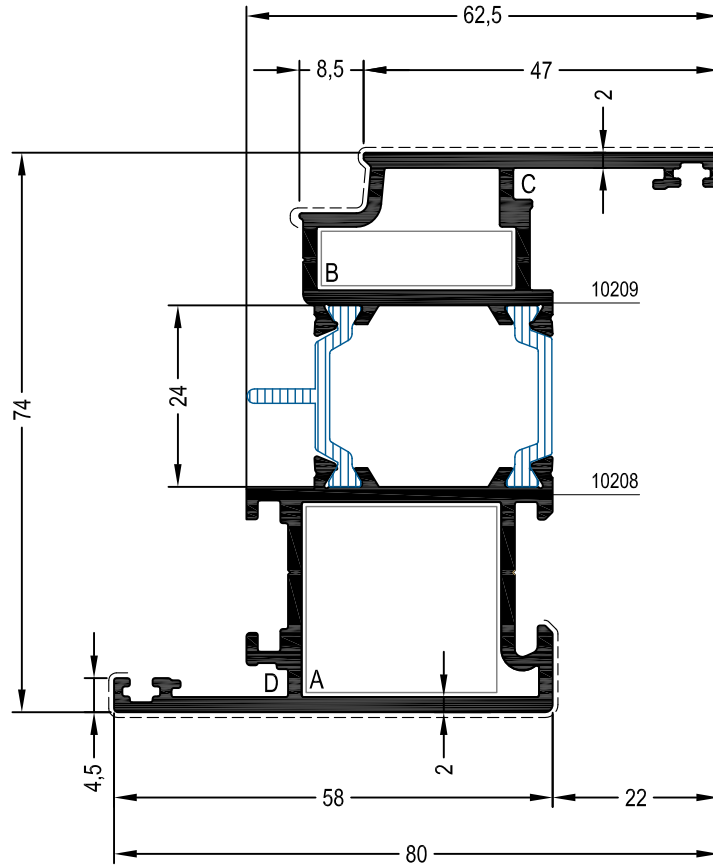

VENT PROFILE 58			
PROFILE CODE		19VW02	
		THEORETICAL WEIGHT kg/mt	
		1.898	
Jxx (cm ⁴)	Jyy (cm ⁴)	Covering Surface (cm)	
		10209	10208
59.930	20.865	7.410	7.739
THERMO BREAK		LOCAL (Pvc)	

CORNER CLEATS		A	B
		C	D
PRESS CORNER		14LW32	14LW32
		----	----
DIE-CAST CORNER JOINT		----	M.fuji 2000
		----	----
P.V.C. CORNER JOINT		----	MO 20
		----	----

INSIDE OPENING VENT PROFILES

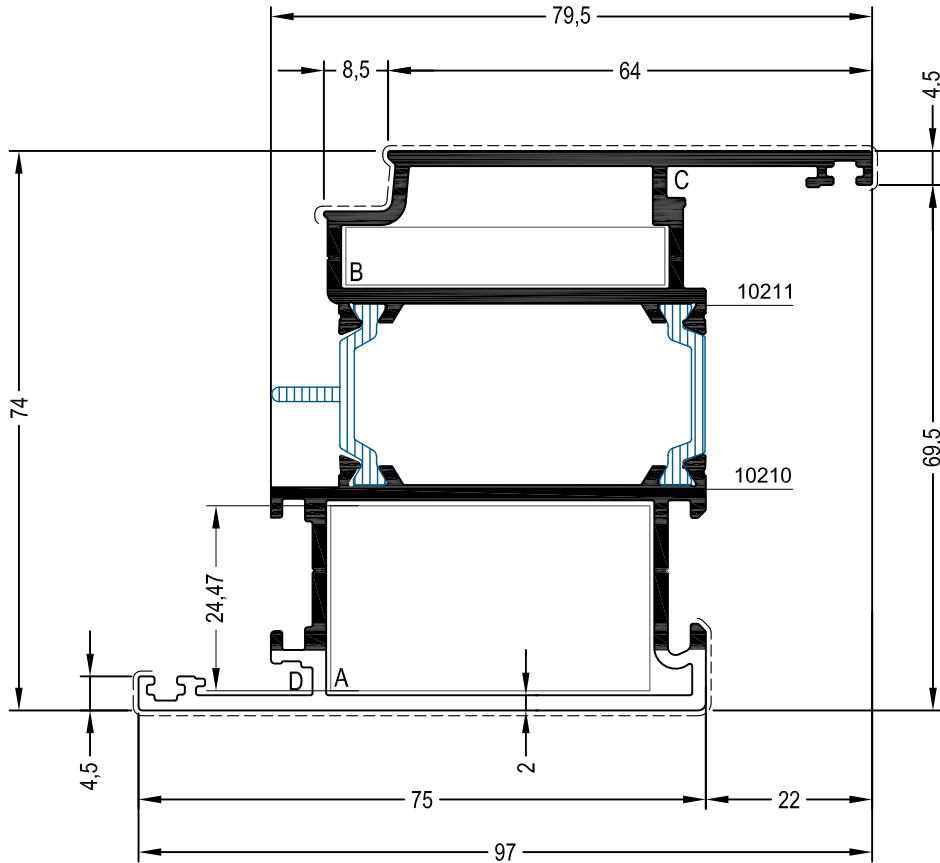

VENT PROFILE		75			
PROFILE CODE		19VW03		THEORETICAL WEIGHT kg/mt	
				2.266	
Jxx (cm ⁴)	Jyy (cm ⁴)	Covering Surface (cm)			
		10211	10210		
60.166	30.842	9.110	9.439		
THERMO BREAK		LOCAL (Pvc)		----	
CORNER CLEATS		A	B	C	D
PRESS CORNER		14LW33	14LW33	----	----
DIE-CAST CORNER JOINT		----	----	M.fuji 2000	----
P.V.C. CORNER JOINT		----	----	----	MO 20

INSIDE OPENING VENT PROFILES

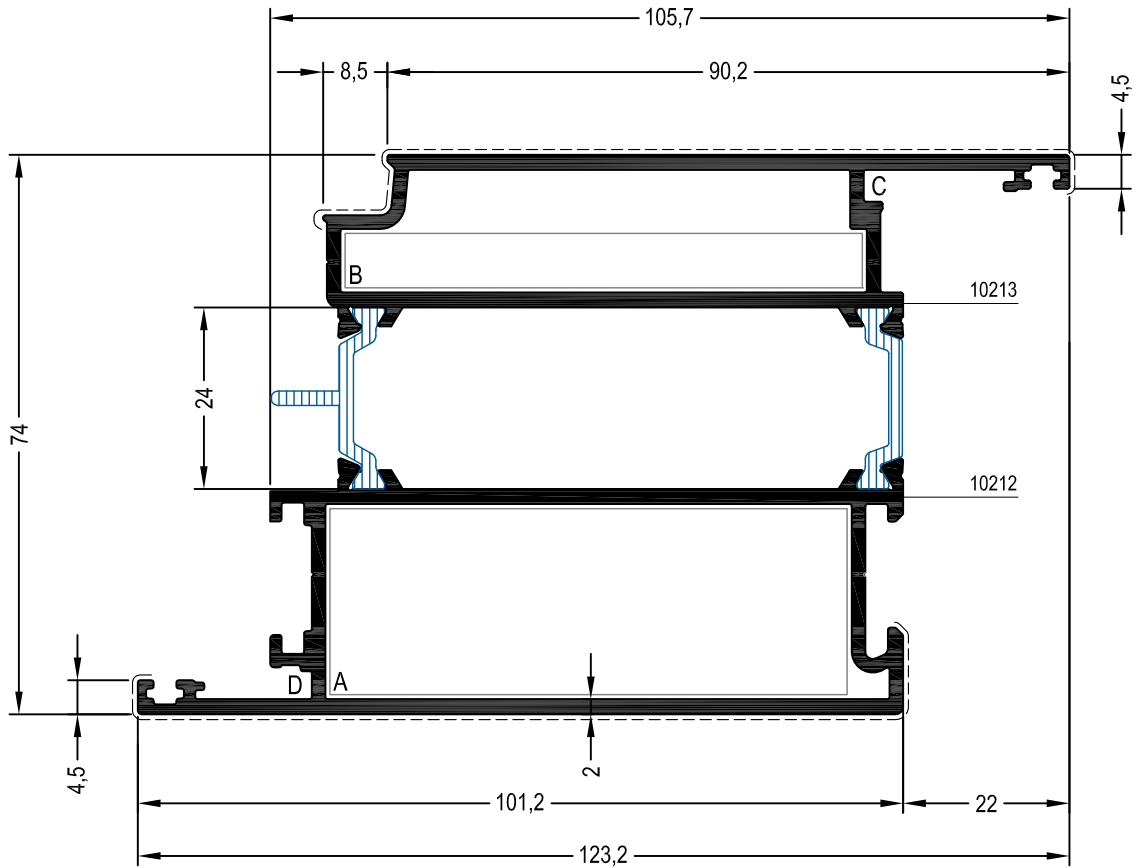



INSIDE OPENING VENT PROFILE 101.2

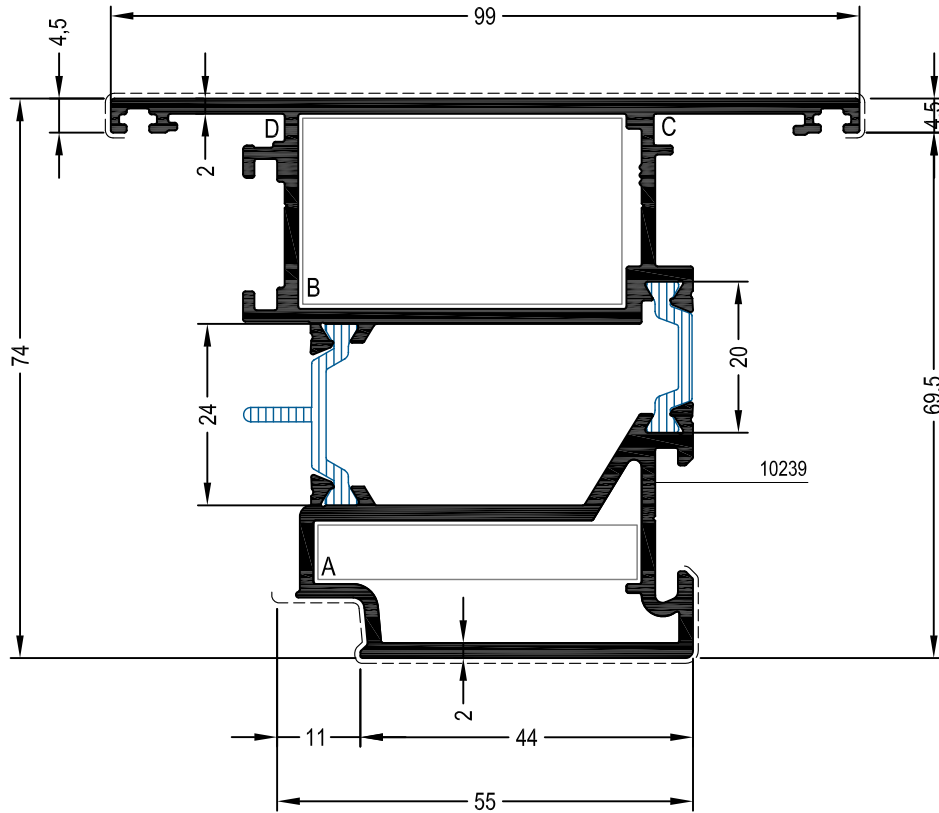

PROFILE CODE		19VW04		THEORETICAL WEIGHT kg/mt	
				2.835	
Jxx (cm ⁴)	Jyy (cm ⁴)	Covering Surface (cm)			
		10213	10212		
52.031	114.999	11.647	12.059		
THERMO BREAK		LOCAL (Pvc)		----	
CORNER CLEATS		A	B	C	D
PRESS CORNER		14LW34	14LW34	----	----
DIE-CAST CORNER JOINT		----	----	M.fuji 2000	----
P.V.C. CORNER JOINT		----	----	----	MO 20

OUTSIDE OPENING VENT PROFILES



OUTSIDE OPENING VENT PROFILE 44			
PROFILE CODE		19VW05	
		THEORETICAL WEIGHT kg/mt	
		2.381	
Jxx (cm ⁴)	Jyy (cm ⁴)	Covering Surface (cm)	
		10240	10239
49.750	44.641	11.279	7.675
THERMO BREAK		LOCAL (Pvc) -----	
CORNER CLEATS		A	B
PRESS CORNER		14LW33	14LW33
DIE-CAST CORNER JOINT		-----	M.fuji 2000
P.V.C. CORNER JOINT		-----	MO 20

OUTSIDE OPENING VENT PROFILES

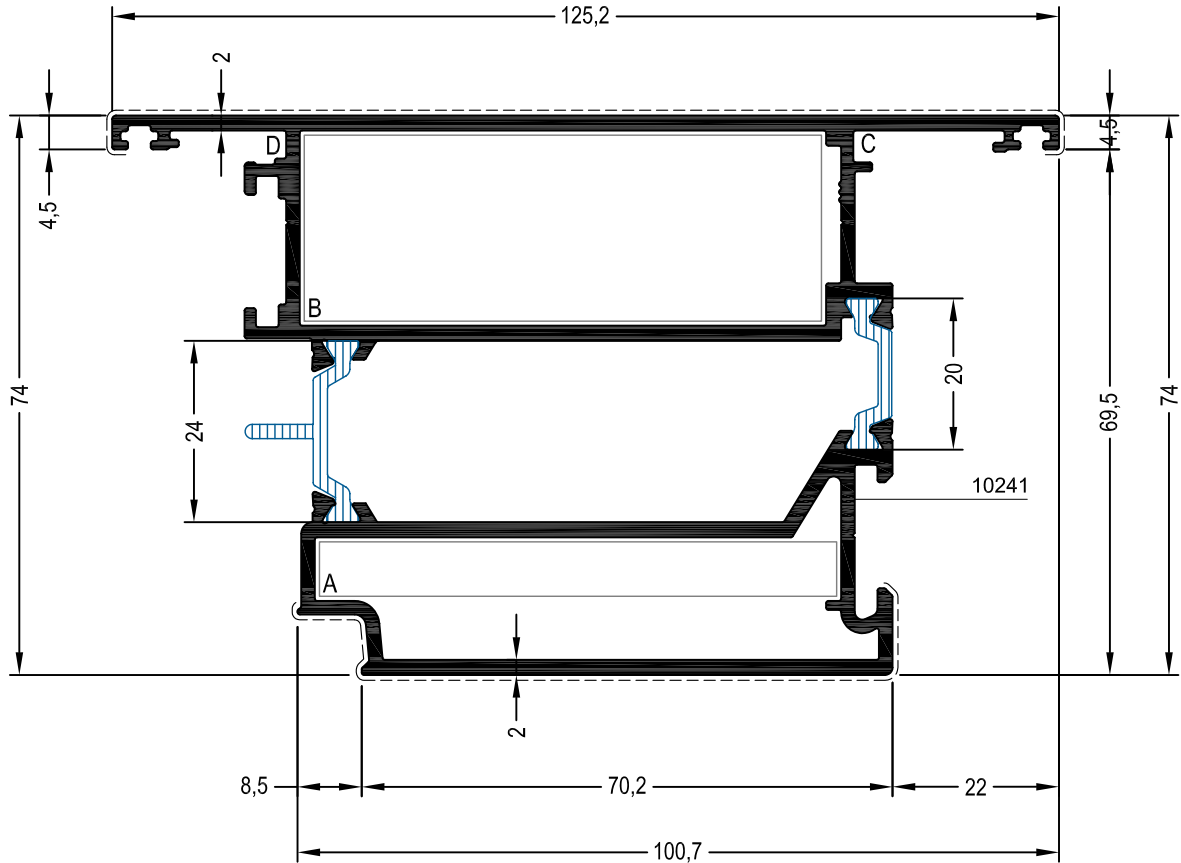

OUTSIDE OPENING VENT PROFILE 70.2					
PROFILE CODE		19VW06		THEORETICAL WEIGHT kg/mt	
				2.952	
Jxx (cm ⁴)	Jyy (cm ⁴)	Covering Surface (cm)			
		10242	10241		
59.304	114.659	13.899	10.357		
THERMO BREAK		LOCAL (Pvc)			

CORNER CLEATS		A	B	C	D
PRESS CORNER		14LW34	14LW34	----	----
DIE-CAST CORNER JOINT		----	----	M.fuji 2000	----
P.V.C. CORNER JOINT		----	----	----	MO 20

VENTS

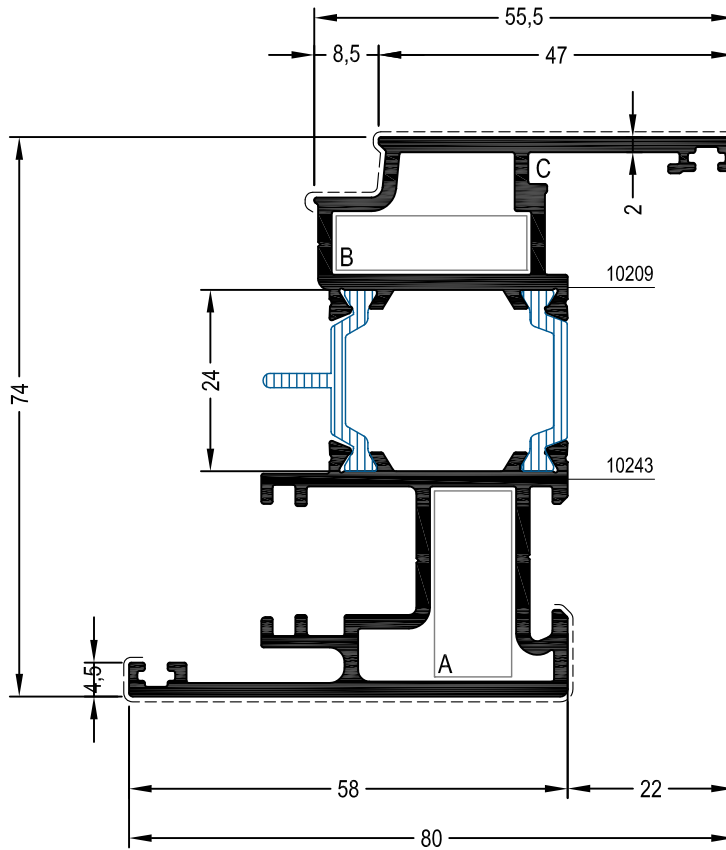

VENT PROFILE 58			
PROFILE CODE		19VW08	
		THEORETICAL WEIGHT kg/mt	
		1.960	
Jxx (cm ⁴)	Jyy (cm ⁴)	Covering Surface (cm)	
		10209	10243
43.773	14.745	7.410	7.797
THERMO BREAK		LOCAL (Pvc)	
		----	----
CORNER CLEATS		A	B
		C	D
PRESS CORNER		14LW14	14LW32
DIE-CAST CORNER JOINT		----	----
P.V.C. CORNER JOINT		----	----
		M.fuji 2000	

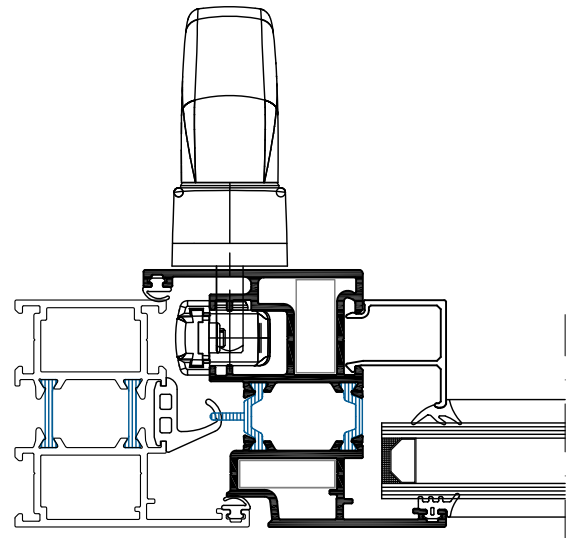

VENTS

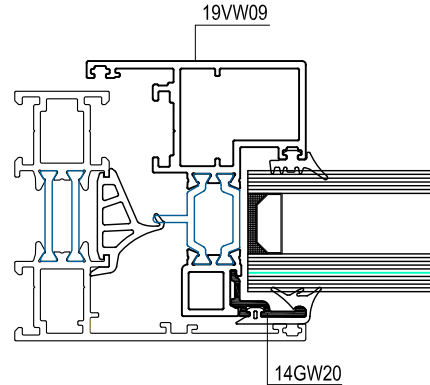
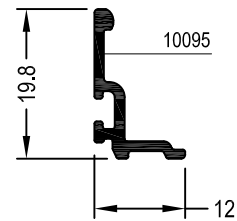
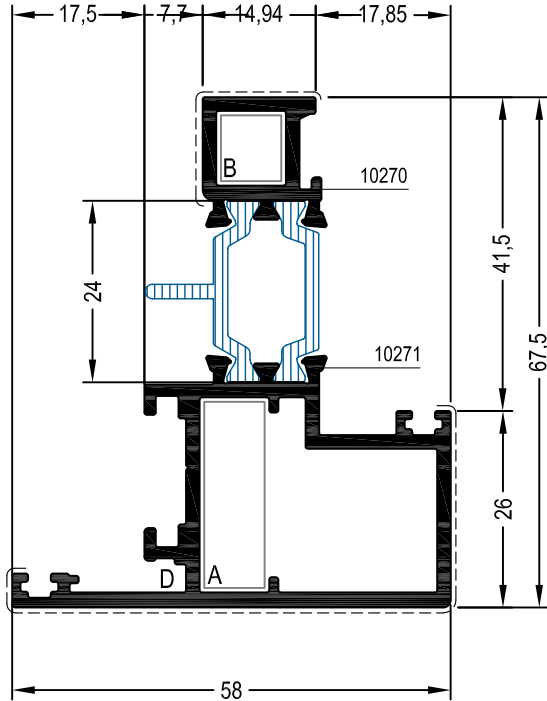

VENT PROFILE 58



PROFILE CODE		19VW09		THEORETICAL WEIGHT kg/mt	
				1.447	
Jxx (cm ⁴)	Jyy (cm ⁴)	Covering Surface (cm)			
		10270	10271		
21.938	9.398	3.246	9.307		
THERMO BREAK		LOCAL (Pvc)		----	
CORNER CLEATS		A	B	C	D
PRESS CORNER		14LW45	14LW45	----	----
DIE-CAST CORNER JOINT		----	----	----	----
P.V.C. CORNER JOINT		----	----	----	MO 20

GLAZING BEAD 12 / 19.8



PROFILE CODE		14GW20		THEORETICAL WEIGHT kg/mt	
				0.132	
Jxx (cm ⁴)	Jyy (cm ⁴)	Covering Surface (cm)			
		10095			
-----	-----	-----			

VENTS for P.V.C. ACCESSORIES

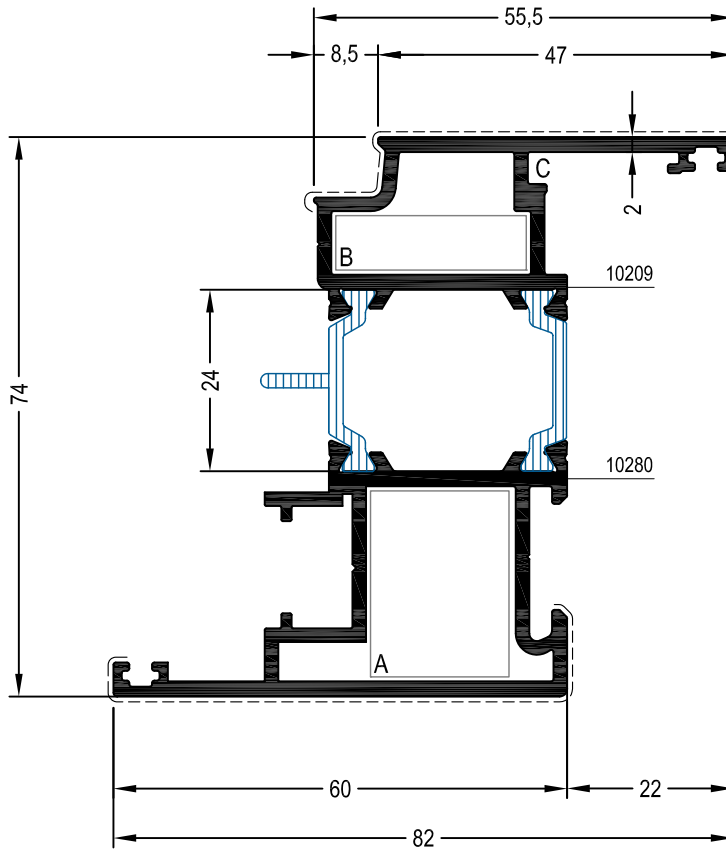

VENT PROFILE 60			
PROFILE CODE		19VW11	
		THEORETICAL WEIGHT kg/mt	
		1.930	
Jxx (cm ⁴)	Jyy (cm ⁴)	Covering Surface (cm)	
		10209	10280
44.486	14.826	7.410	7.997
THERMO BREAK		LOCAL (Pvc) -----	
CORNER CLEATS		A	B
PRESS CORNER		14LW35	14LW32
DIE-CAST CORNER JOINT		-----	M.fuji 2000
P.V.C. CORNER JOINT		-----	-----

MULLION

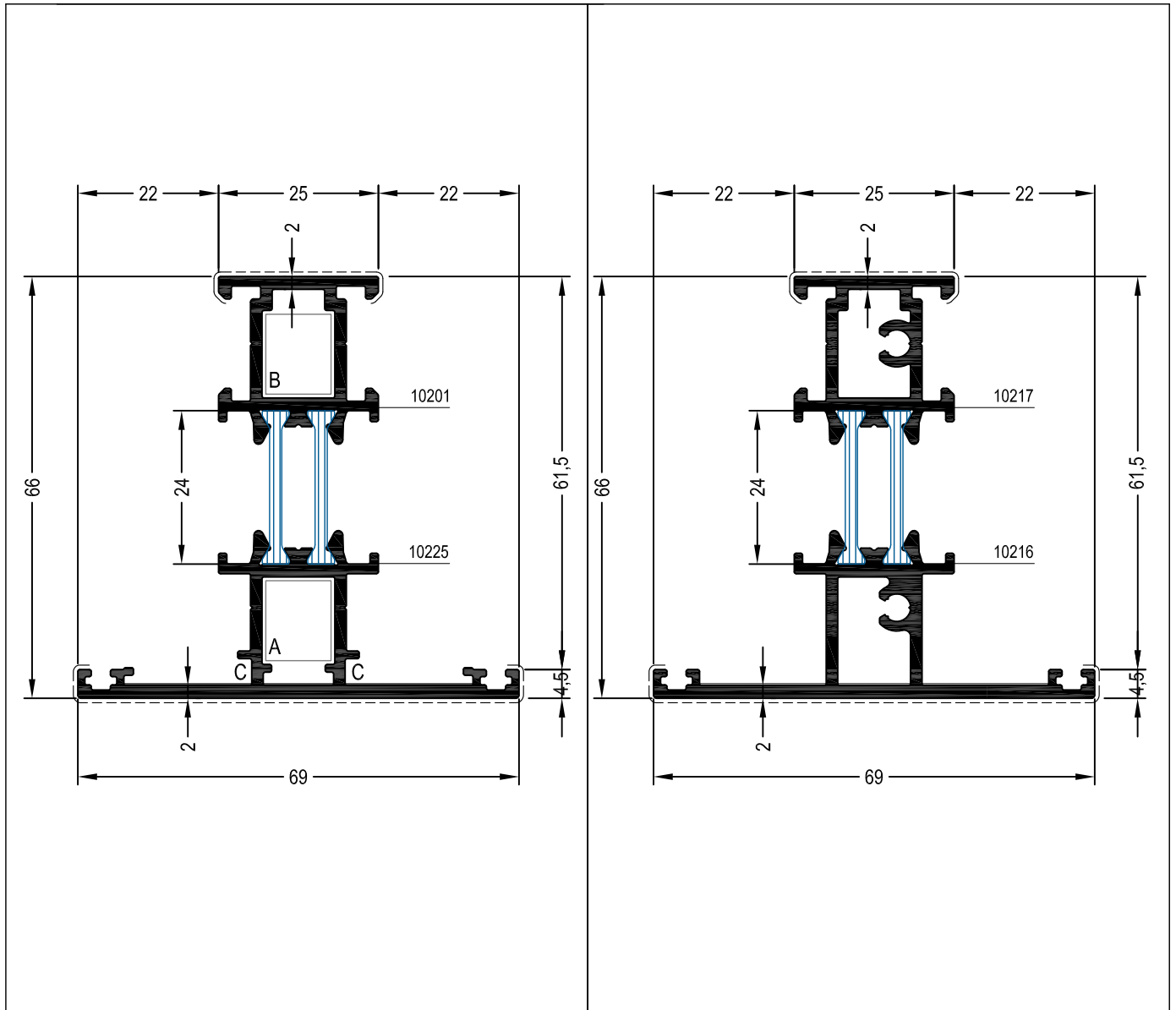

TRANSOM MULLION PROFILE				25 / 69				
PROFILE CODE		19MW01		THEORETICAL WEIGHT kg/mt		1.499		
Jxx (cm ⁴)	Jyy (cm ⁴)	Covering Surface (cm)		TRANSOM MULLION PROFILE		25 / 69		
22.760	8.590	10201	10225			THEORETICAL WEIGHT kg/mt		
		3.465	8.279	PROFILE CODE		19MW04		
THERMO BREAK		LOCAL (Pvc)		THERMO BREAK		LOCAL (Pvc)		
T JUNCTION		A	B	C	Jxx (cm ⁴)	Jyy (cm ⁴)	Covering Surface (cm)	
CORNER CLEATS		A	B	C	23.864	8.636	10217	10216
		14JW05	14JW04	-----			3.465	8.279
		14LW14	14LW14	M.fuji 2000	THERMO BREAK		-----	

MULLION

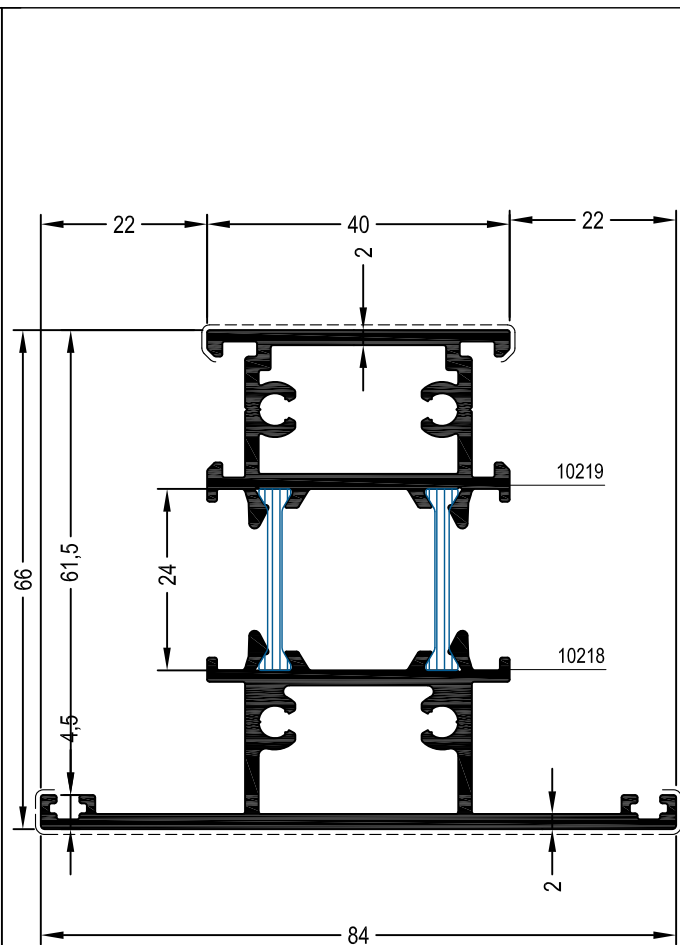
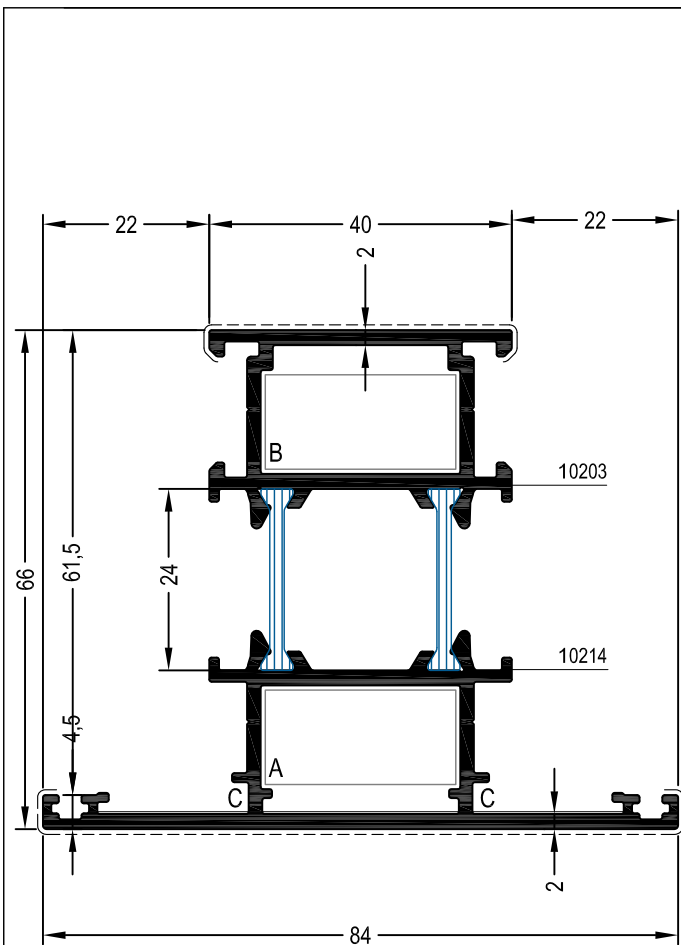



TRANSOM MULLION PROFILE 40 / 84 

PROFILE CODE	19MW02	THEORETICAL WEIGHT kg/mt
		1.834

Jxx (cm4)	Jyy (cm4)	Covering Surface (cm)	
		10203	10214
28.683	20.061	4.965	9.779

THERMO BREAK	LOCAL (Pvc)	----
--------------	-------------	------

T JUNCTION		A	B	C
		14JW05	14JW04	----

CORNER CLEATS		A	B	C
		14LW32	14LW32	M.fuji 2000

TRANSOM MULLION PROFILE 40 / 84 



PROFILE CODE	19MW05	THEORETICAL WEIGHT kg/mt
		2.007

Jxx (cm4)	Jyy (cm4)	Covering Surface (cm)	
		10219	10218
30.945	21.025	4.965	9.779

THERMO BREAK	LOCAL (Pvc)	----
--------------	-------------	------

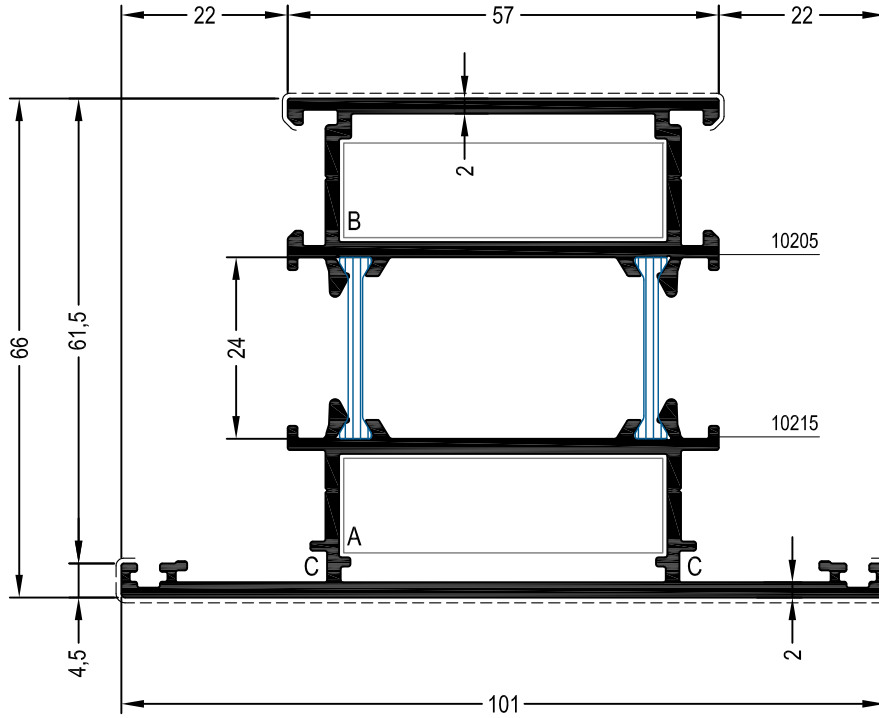
MULLION



TRANSOM MULLION PROFILE 57 / 101				
PROFILE CODE		19MW03		THEORETICAL WEIGHT kg/mt
				2.202
Jxx (cm ⁴)	Jyy (cm ⁴)	Covering Surface (cm)		
		10205	10215	
42.758	35.277	6.665	11.479	
THERMO BREAK		LOCAL (Pvc)		----
T JUNCTION		A	B	C
		14JW05	14JW04	----
CORNER CLEATS		A	B	C
		14LW33	14LW33	M.fuji 2000

MULLION

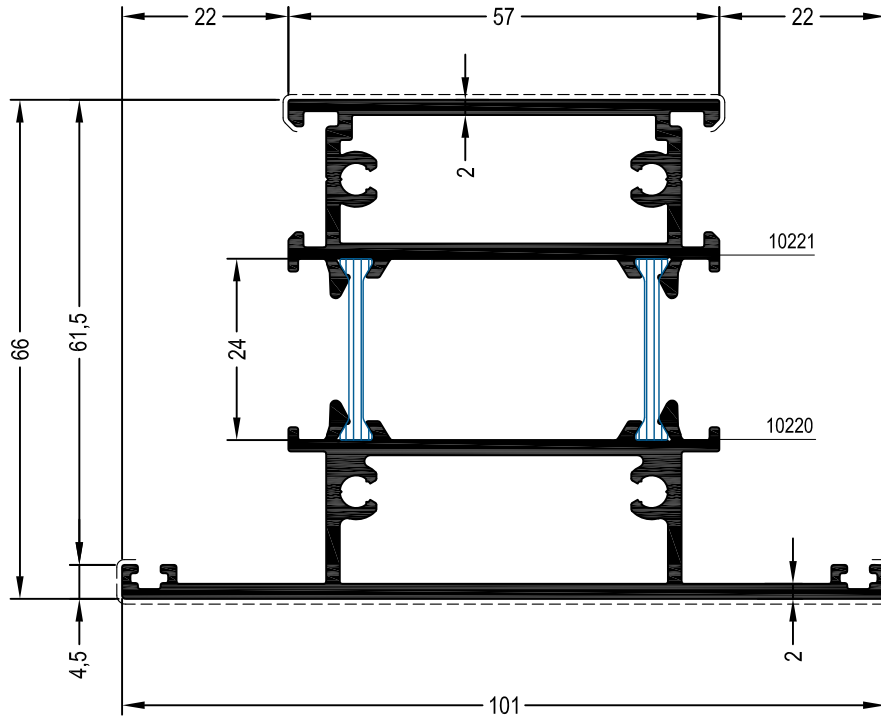

TRANSOM MULLION PROFILE 57 / 101					
PROFILE CODE		19MW06		THEORETICAL WEIGHT kg/mt	
				2.375	
Jxx (cm ⁴)	Jyy (cm ⁴)	Covering Surface (cm)			
		10221	10220		
45.532	37.493	6.665	11.479		
THERMO BREAK		LOCAL (Pvc)		-----	

MULLION

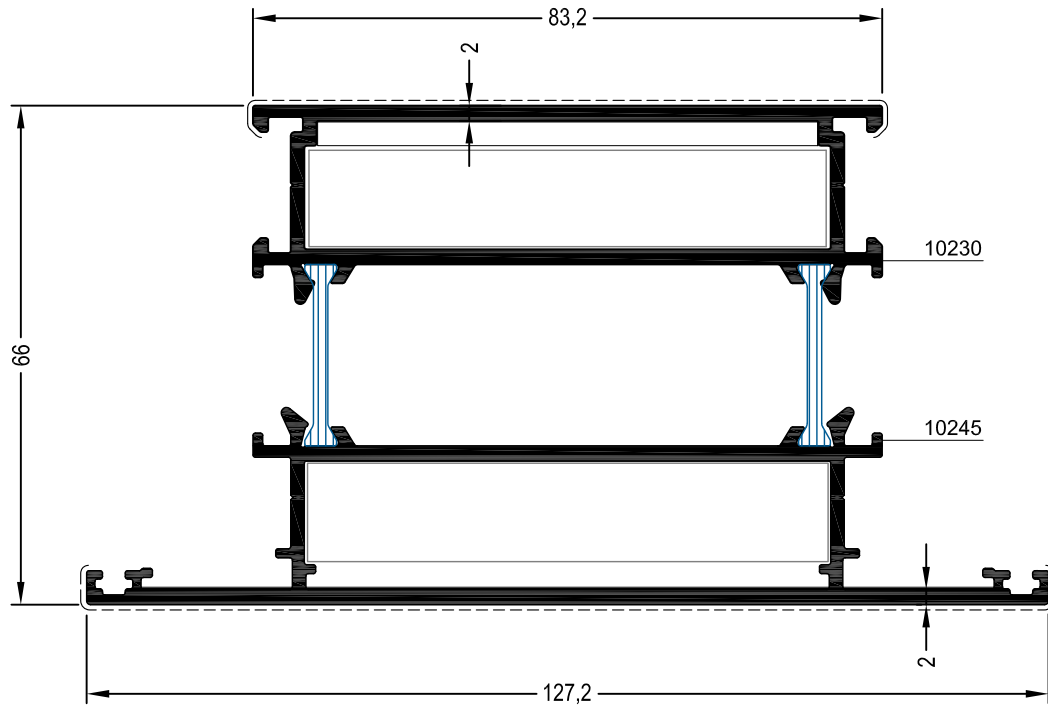

TRANSOM MULLION PROFILE 86 / 130						
PROFILE CODE		19MW07		THEORETICAL WEIGHT kg/mt		
				2.768		
Jxx (cm ⁴)	Jyy (cm ⁴)	Covering Surface (cm)				
		10244	10245			
46.415	110.679	9.565	14.379			
THERMO BREAK		LOCAL (Pvc) ----				
T JUNCTION		A	B	C		
		14JW05	14JW04	----		
CORNER CLEATS		A	B	C		
		14LW34	14LW34	M.fuji 2000		

MULLION

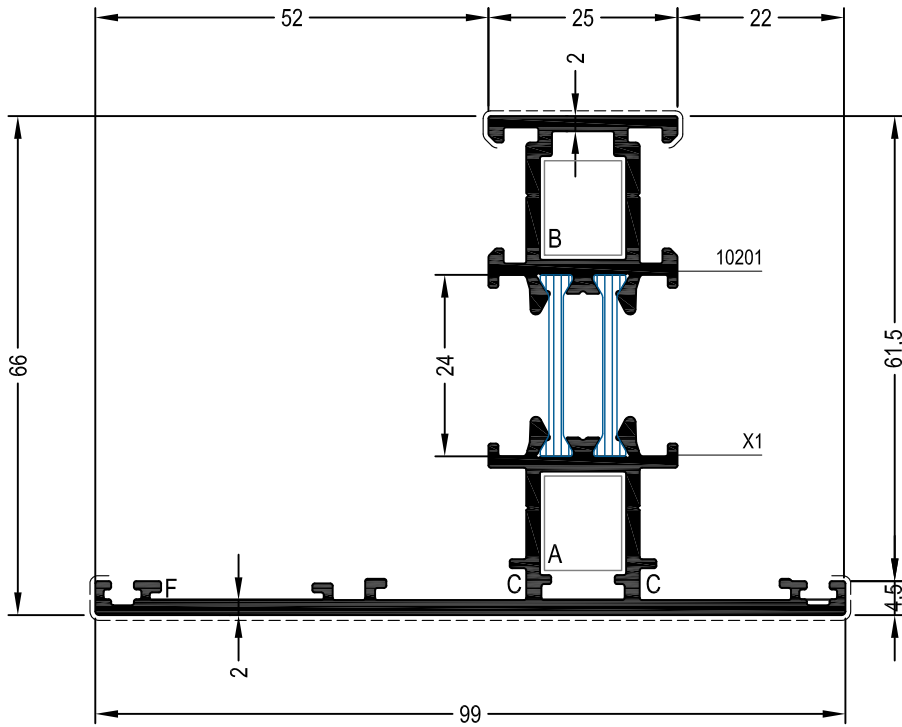

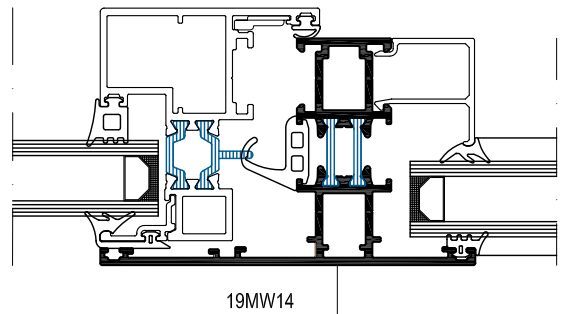

TRANSOM MULLION PROFILE 25 / 99						
PROFILE CODE		19MW14		THEORETICAL WEIGHT kg/mt		
				1.695		
Jxx (cm ⁴)	Jyy (cm ⁴)	Covering Surface (cm)				
		10201	X1			
33.114	18.308	3.465	11.299			
THERMO BREAK		LOCAL (Pvc) -----				
T JUNCTION		A	B	C		
		14JW05	14JW04	-----	-----	
CORNER CLEATS		A	B	C	F	
		14LW14	14LW14	M.fuji 2000	STEEL	

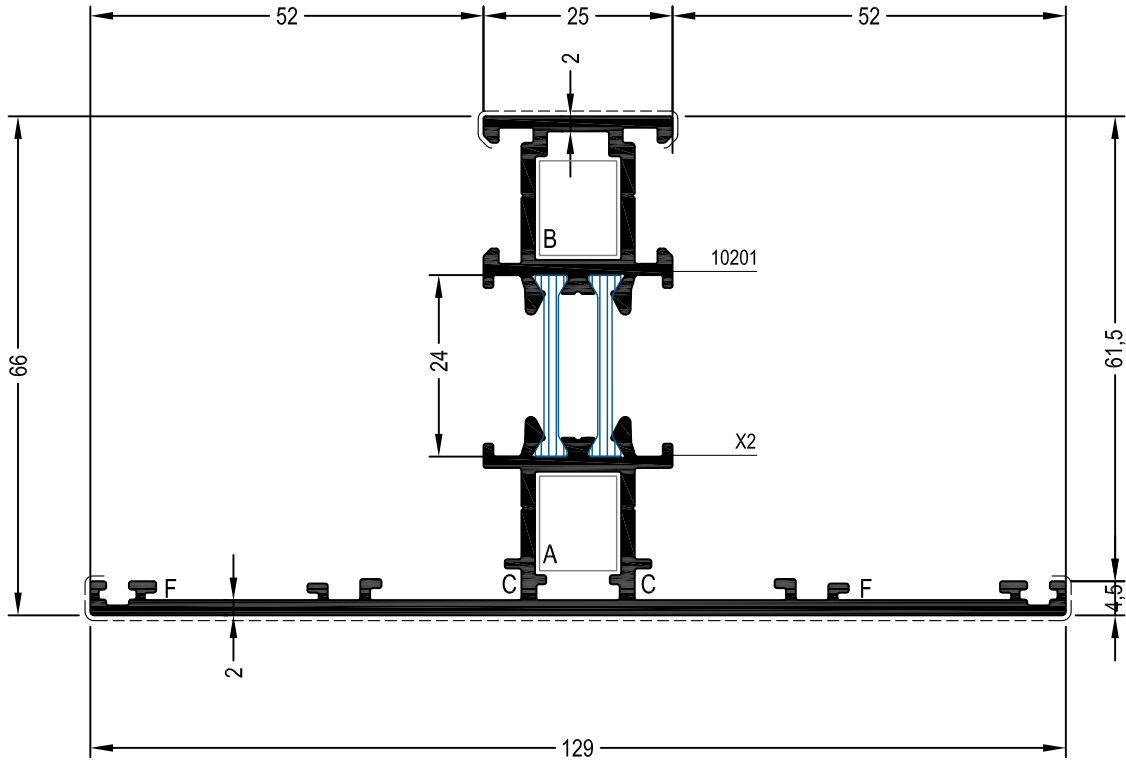

MULLION



TRANSOM MULLION PROFILE 25 / 129				
PROFILE CODE		19MW15		THEORETICAL WEIGHT kg/mt
				1.885
Jxx (cm ⁴)	Jyy (cm ⁴)	Covering Surface (cm)		
		10201	X2	
45.113	29.198	3.465	14.278	
THERMO BREAK		LOCAL (Pvc) -----		
T JUNCTION		A	B	C
		14JW05	14JW04	-----
CORNER CLEATS		A	B	C
		14LW14	14LW14	M.fuji 2000
				STEEL

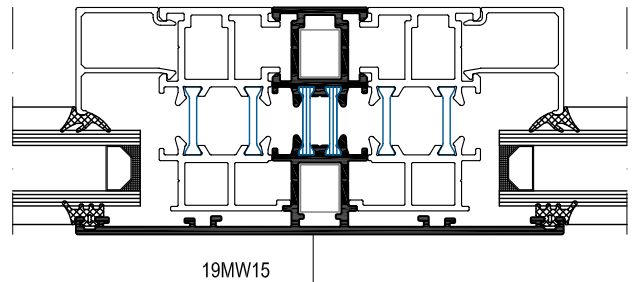

MULLION

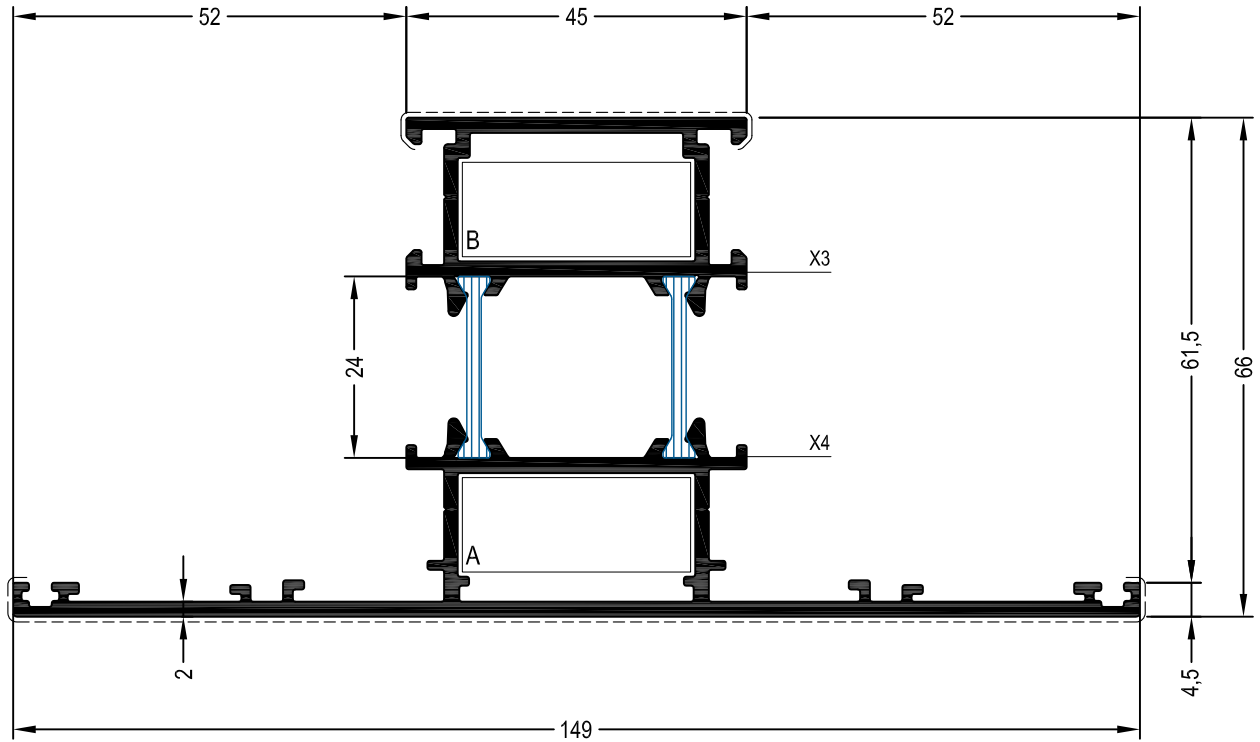

TRANSOM MULLION PROFILE 45 / 149			
PROFILE CODE		19MW16	
		THEORETICAL WEIGHT kg/mt	
		2.323	
Jxx (cm ⁴)	Jyy (cm ⁴)	Covering Surface (cm)	
		X3	X4
77.666	37.979	5.465	16.278
THERMO BREAK		LOCAL (Pvc)	
T JUNCTION		A	B
		14JW05	14JW04
			C

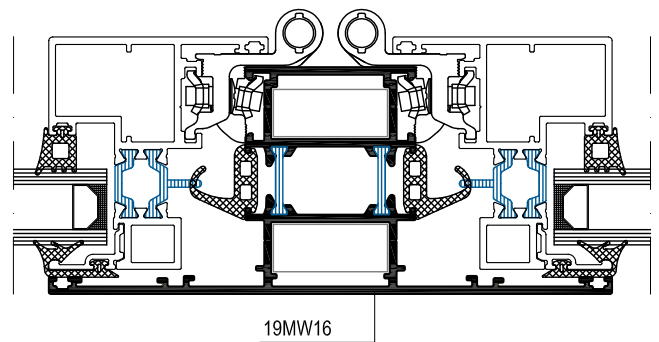

MULLION

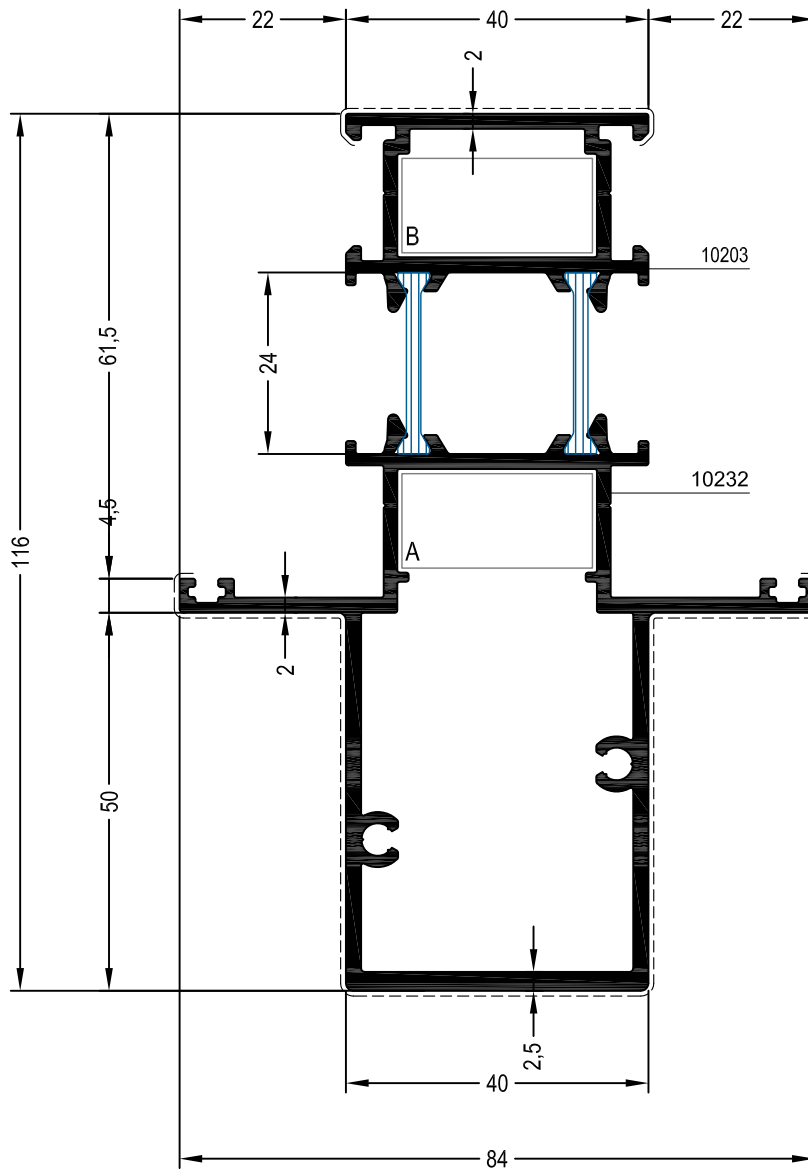

TRANSOM MULLION PROFILE 40 / 84			
PROFILE CODE		19MW08	
		THEORETICAL WEIGHT kg/mt	
		2.547	
Jxx (cm ⁴)	Jyy (cm ⁴)	Covering Surface (cm)	
		10203	10232
109.702	28.479	4.965	19.608
THERMO BREAK		LOCAL (Pvc) -----	
T JUNCTION		A	B
		14JW05	14JW04
			C

MULLION

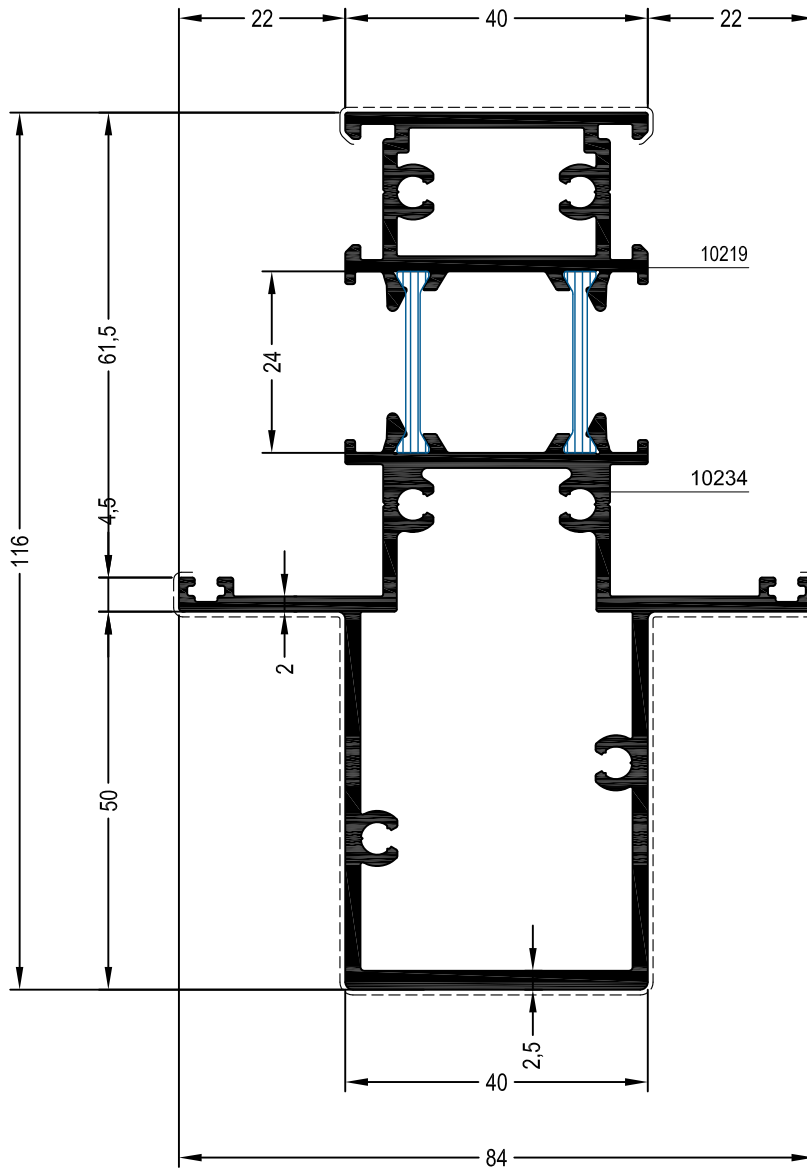

TRANSOM MULLION PROFILE 40 / 84					
PROFILE CODE		19MW09		THEORETICAL WEIGHT kg/mt	
				2.738	
Jxx (cm ⁴)	Jyy (cm ⁴)	Covering Surface (cm)			
		10219	10234		
115.270	29.143	4.965	19.608		
THERMO BREAK		LOCAL (Pvc)		----	

MULLION

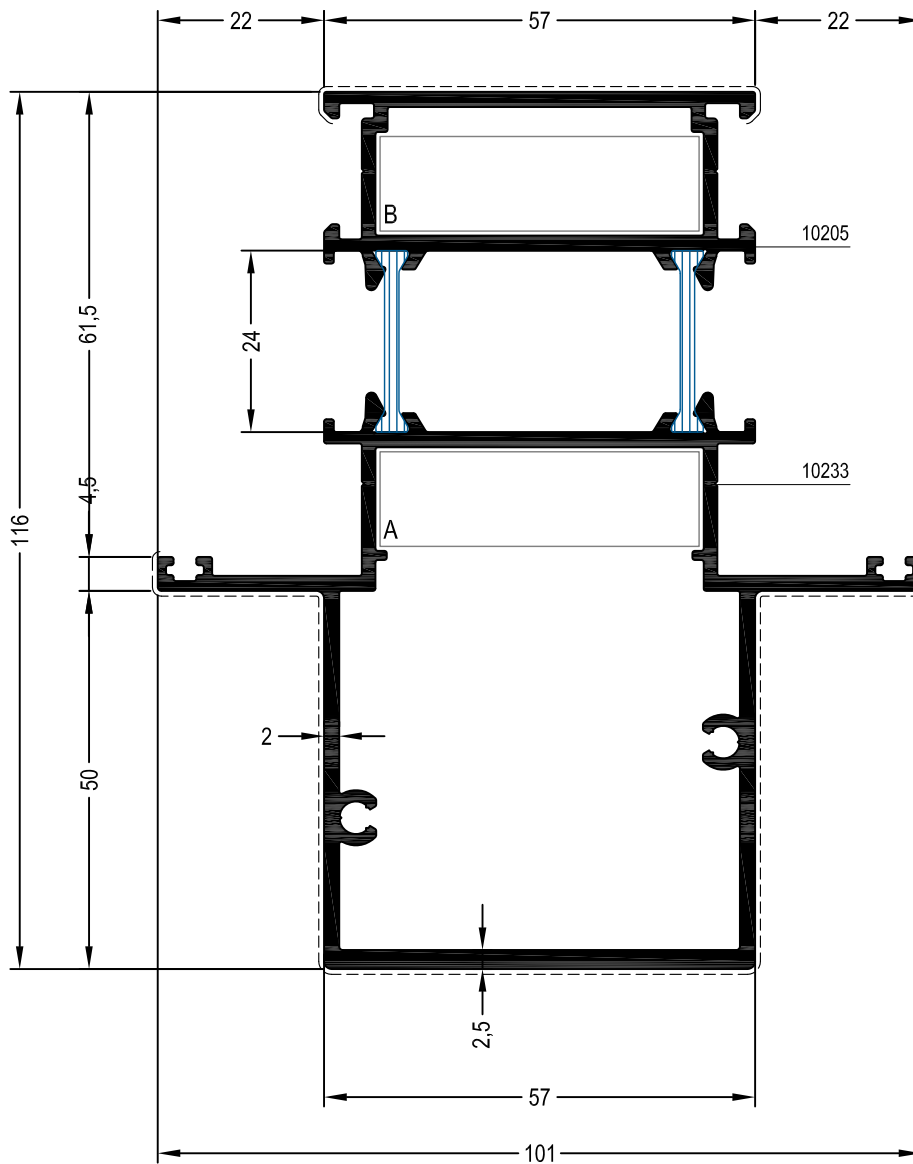

TRANSOM MULLION PROFILE 57 / 101			
PROFILE CODE		19MW10	
		THEORETICAL WEIGHT kg/mt	
		2.937	
Jxx (cm ⁴)	Jyy (cm ⁴)	Covering Surface (cm)	
		10205	10233
136.110	60.716	6.728	21.070
THERMO BREAK		LOCAL (Pvc)	

T JUNCTION		A	B
		14JW05	14JW04

MULLION

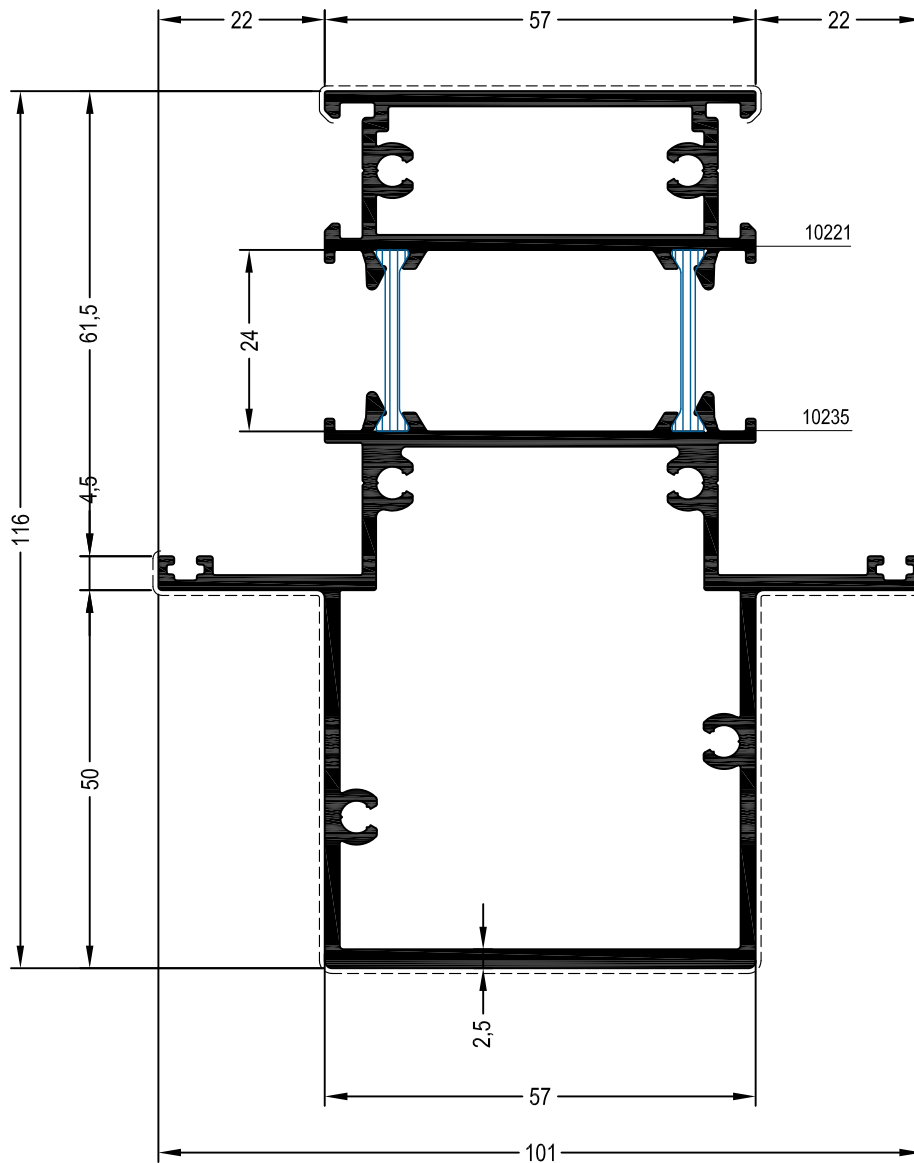

TRANSOM MULLION PROFILE 57 / 101					
PROFILE CODE		19MW11		THEORETICAL WEIGHT kg/mt	
				3.130	
Jxx (cm ⁴)	Jyy (cm ⁴)	Covering Surface (cm)			
		10221	10235		
141.500	63.443	6.728	21.070		
THERMO BREAK					
		LOCAL (Pvc)		----	

MULLION

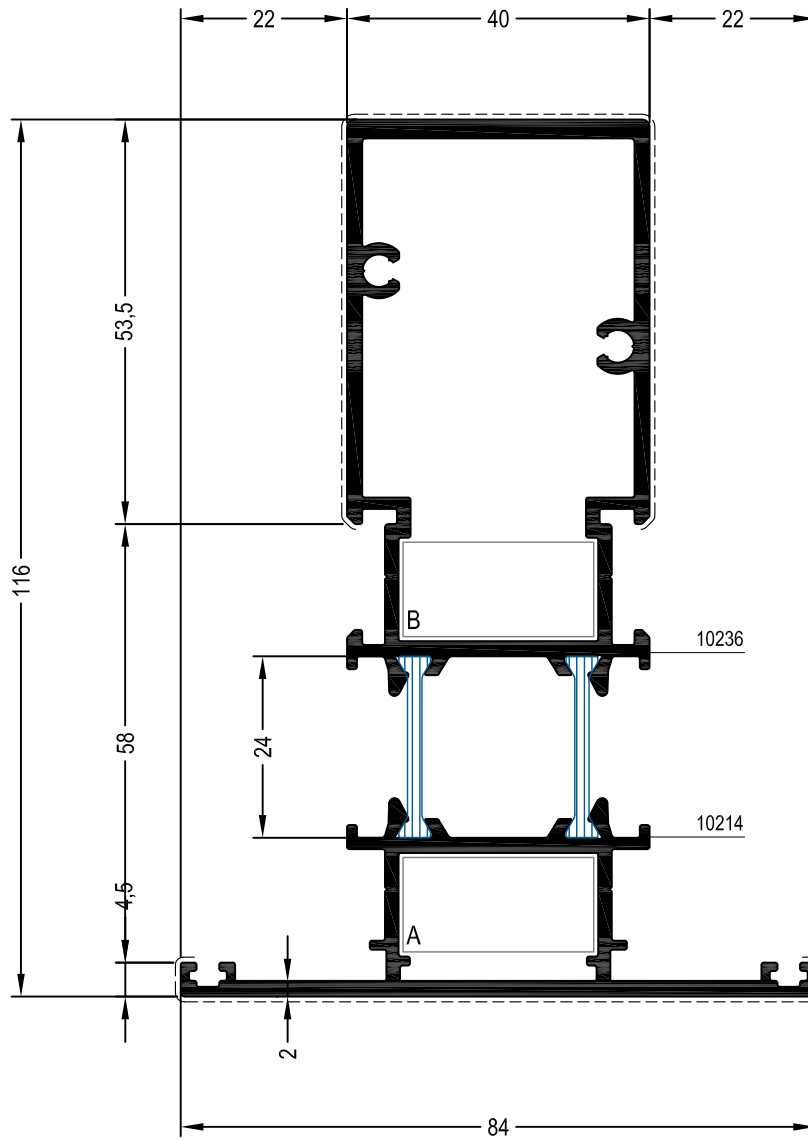

TRANSOM MULLION PROFILE 40 / 84					
PROFILE CODE		19MW12		THEORETICAL WEIGHT kg/mt	
				2.579	
Jxx (cm ⁴)	Jyy (cm ⁴)	Covering Surface (cm)			
		10236	10214		
131.547	28.870	14.905	9.779		
THERMO BREAK		LOCAL (Pvc)		----	
T JUNCTION		A	B	C	
		14JW05	14JW04	----	

MULLION

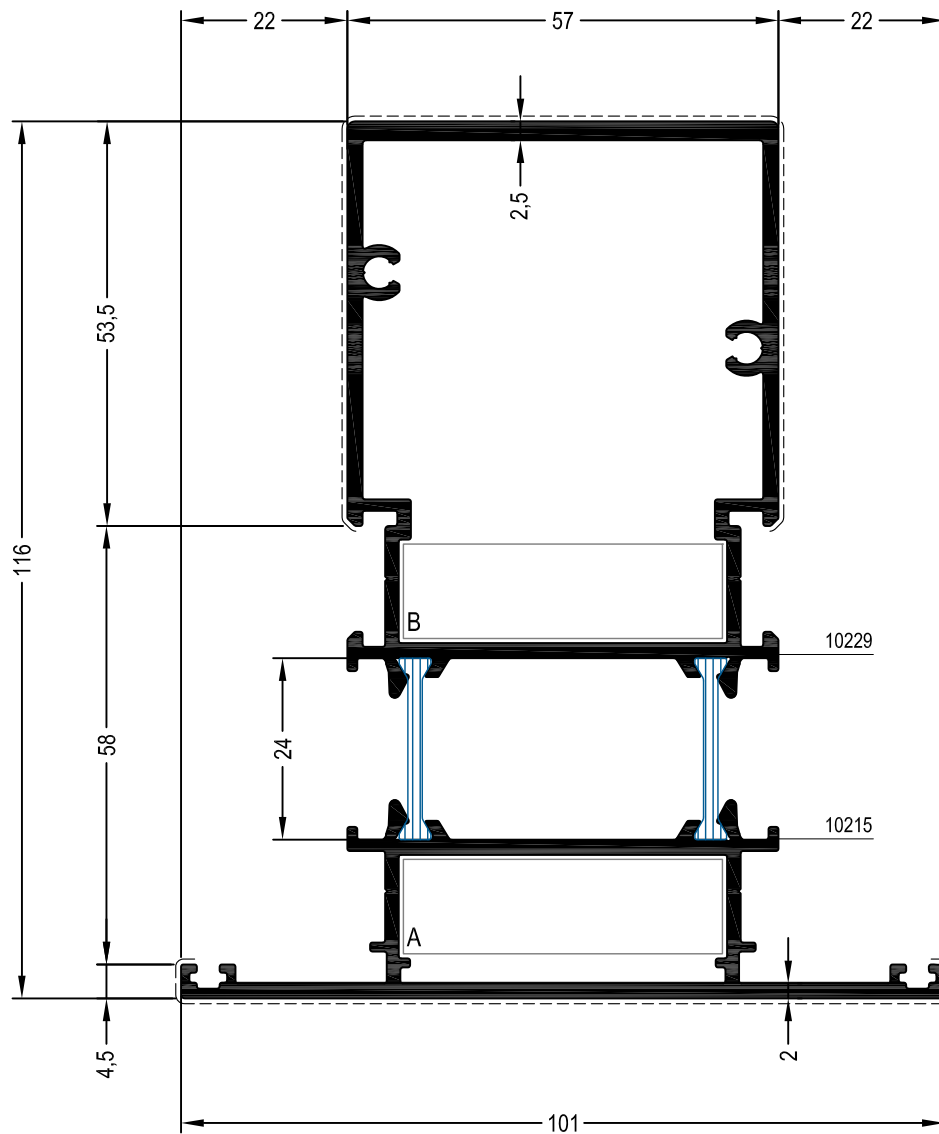

TRANSOM MULLION PROFILE 57 / 101



PROFILE CODE		19MW13		THEORETICAL WEIGHT kg/mt	
				2.971	
Jxx (cm ⁴)	Jyy (cm ⁴)	Covering Surface (cm)			
		10229	10215		
156.969	61.200	16.605	11.479		
THERMO BREAK		LOCAL (Pvc)			

T JUNCTION		A	B	C	
		14JW05	14JW04	----	

MULLION

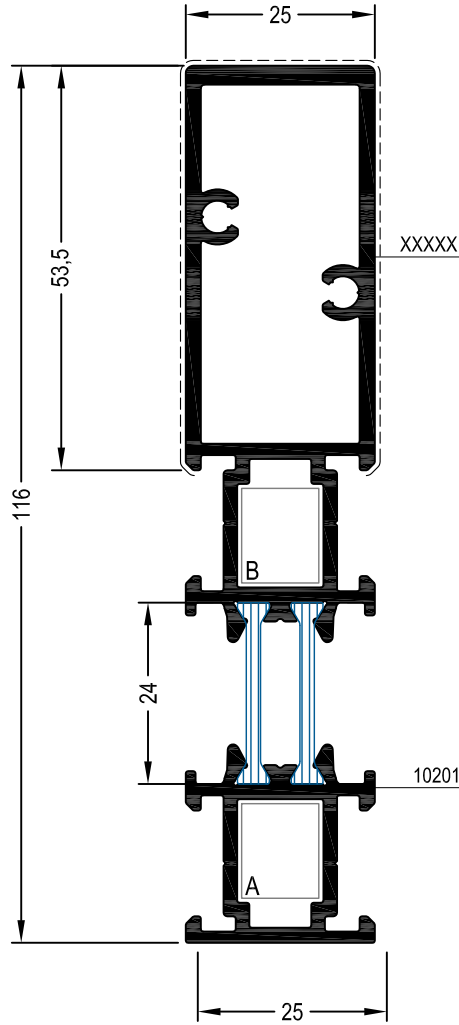

ADAPTER PROFILE 25 / 110			
PROFILE CODE		19AW14	
		THEORETICAL WEIGHT kg/mt	
		2.504	
Jxx (cm ⁴)	Jyy (cm ⁴)	Covering Surface (cm)	
		10201	XXXXX
85.872	5.182	3.465	13.405
THERMO BREAK		LOCAL (Pvc)	

T JUNCTION		A	B
		14JW05	14JW04
		C	-----

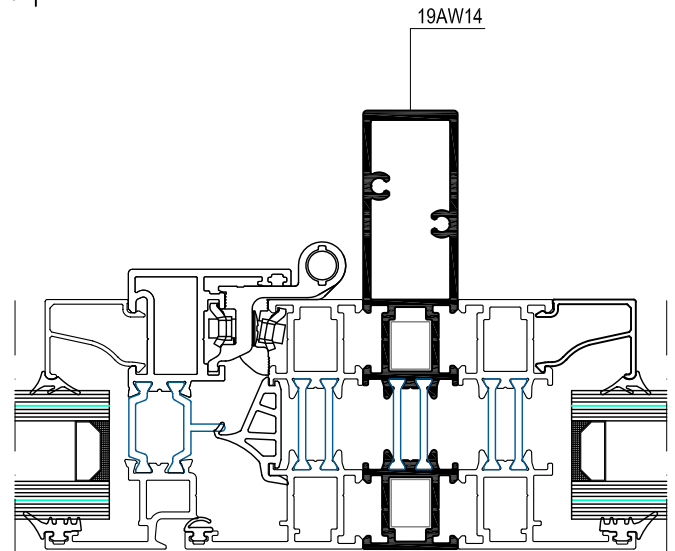

MULLION

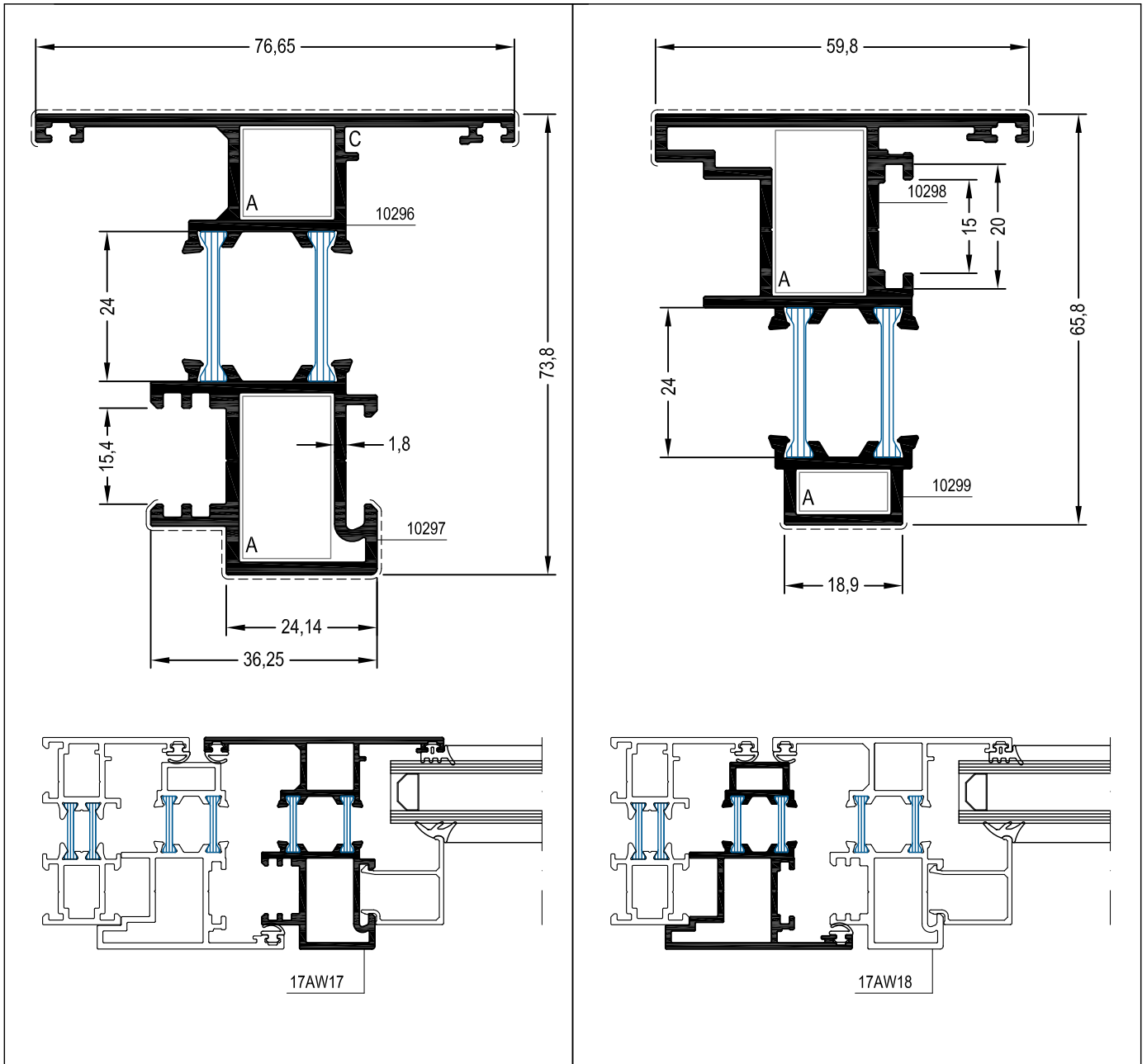

PIVOT VENT PROFILE 76.65 / 67.8				PIVOT ADAPTER 61 / 60											
PROFILE CODE		19AW17		THEORETICAL WEIGHT kg/mt		1.753		PROFILE CODE		19AW18		THEORETICAL WEIGHT kg/mt		1.475	
Jxx (cm ⁴)	Jyy (cm ⁴)	Covering Surface (cm)		Jxx (cm ⁴)	Jyy (cm ⁴)	Covering Surface (cm)		Jxx (cm ⁴)	Jyy (cm ⁴)	Covering Surface (cm)		THERMO BREAK	LOCAL (Pvc)		
34.136	14.285	10296	10297	8.744	6.094	10298	10299	7.378	2.018	THERMO BREAK		LOCAL (Pvc)			
CORNER CLEATS		A	B	C	CORNER CLEATS		A	B	C	CORNER CLEATS			A	B	C
CORNER CLEATS		14LW13	14LW13	M.fuji 2000	CORNER CLEATS		14LW13	14LW13	M.fuji 2000	CORNER CLEATS		A	B	C	
CORNER CLEATS		14LW13	14LW13	M.fuji 2000	CORNER CLEATS		14LW13	14LW13	M.fuji 2000	CORNER CLEATS		A	B	C	

MULLION

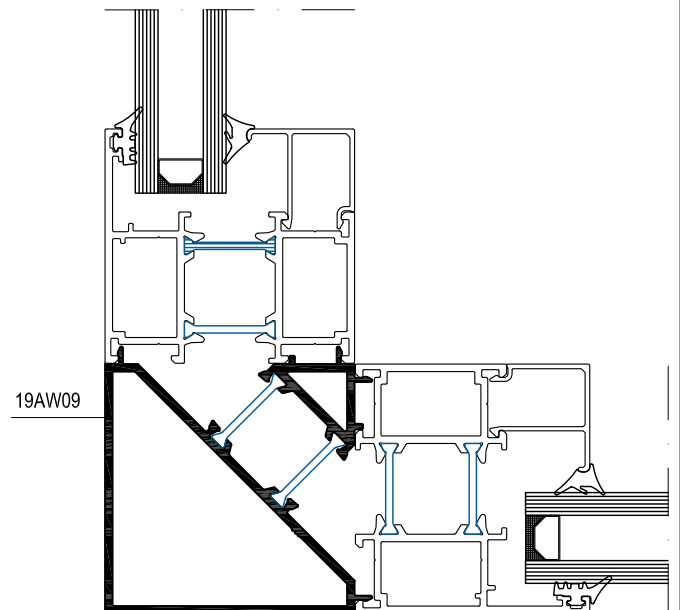
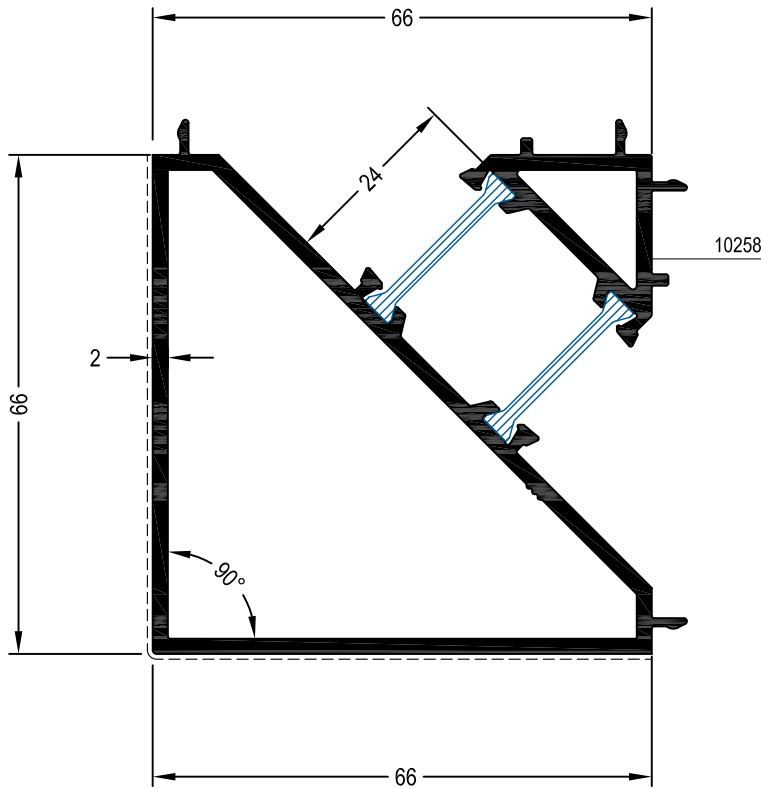

ADAPTER FOR 90° 60 / 60					
PROFILE CODE		19AW09		THEORETICAL WEIGHT kg/mt	
				1.919	
Jxx (cm4)	Jyy (cm4)	Covering Surface (cm)			
		10258		10257	
32.325	28.538	-----		12.025	
THERMO BREAK		LOCAL (Pvc)		-----	

MULLION

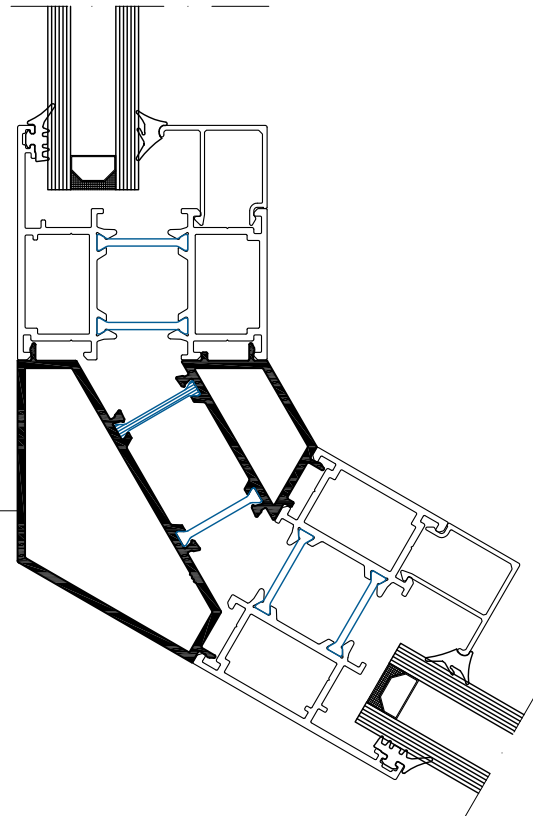
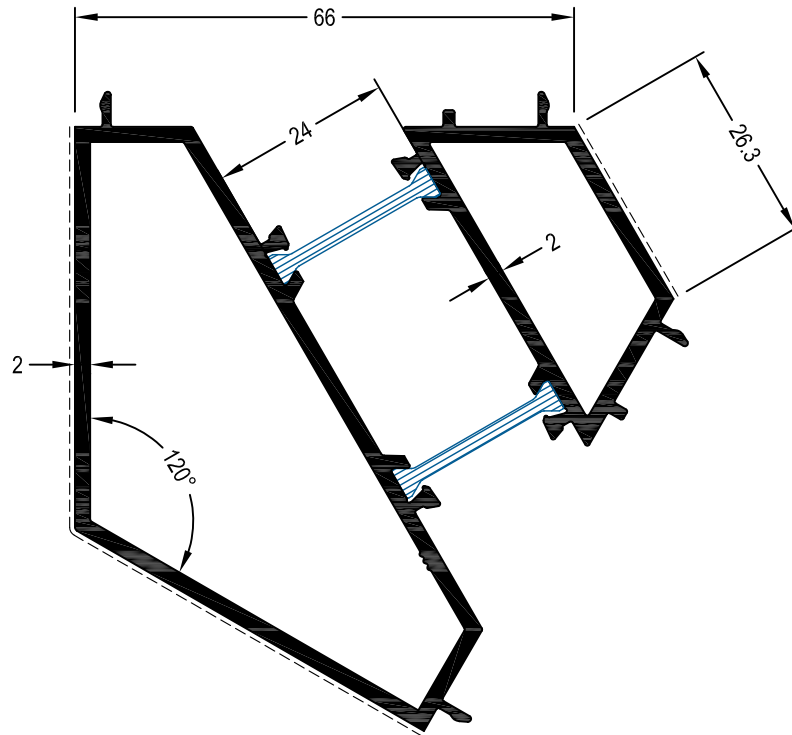

ADAPTER FOR 120° 60 / 60					
PROFILE CODE		19AW10		THEORETICAL WEIGHT kg/mt	
				2.073	
Jxx (cm ⁴)	Jyy (cm ⁴)	Covering Surface (cm)			
		10259		10260	
36.344	34.004	9.986		2.626	
THERMO BREAK		LOCAL (Pvc)		----	

MULLION

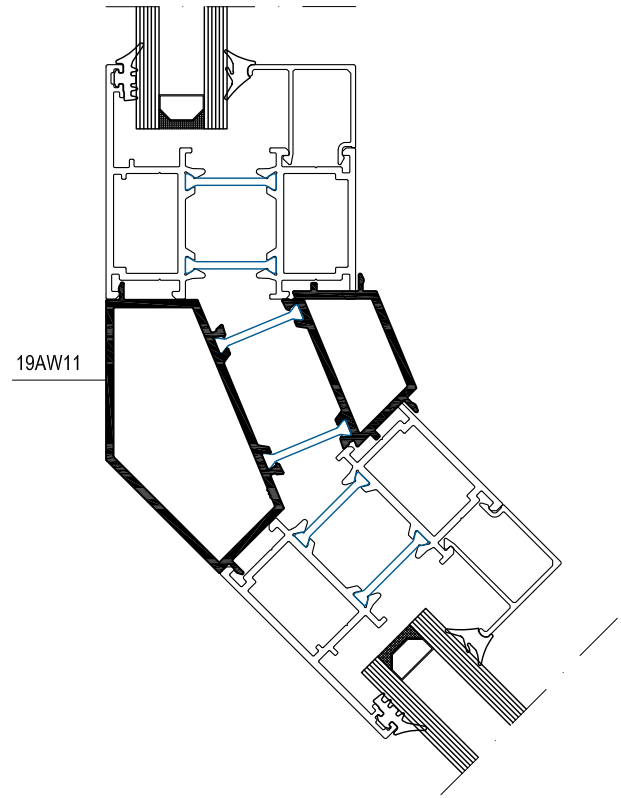
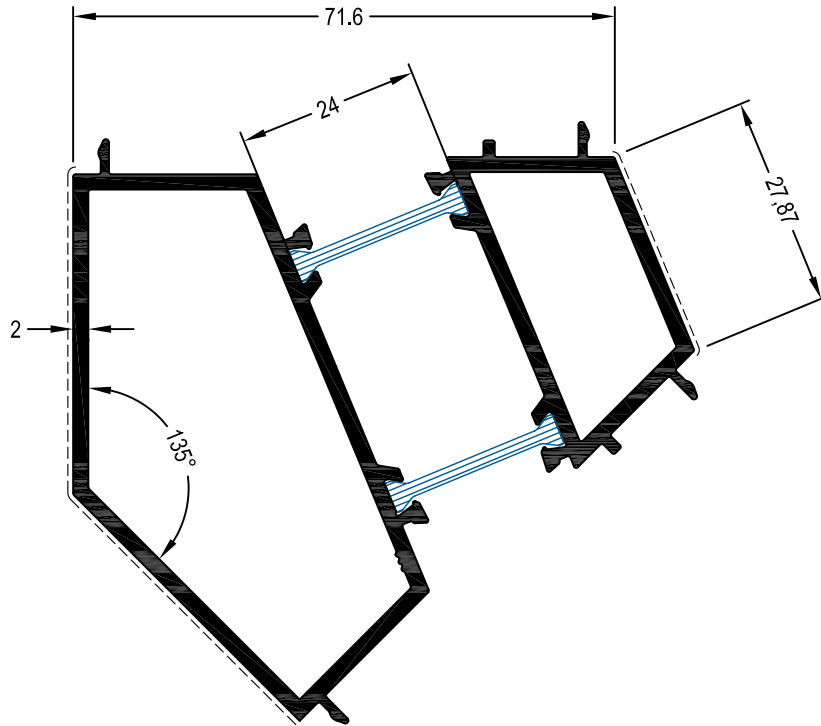

ADAPTER FOR 135° 60 / 60					
PROFILE CODE		19AW11		THEORETICAL WEIGHT kg/mt	
				1.939	
Jxx (cm4)	Jyy (cm4)	Covering Surface (cm)			
		10261	10262		
28.873	26.769	8.056	2.872		
THERMO BREAK		LOCAL (Pvc)			

KICK PLATE

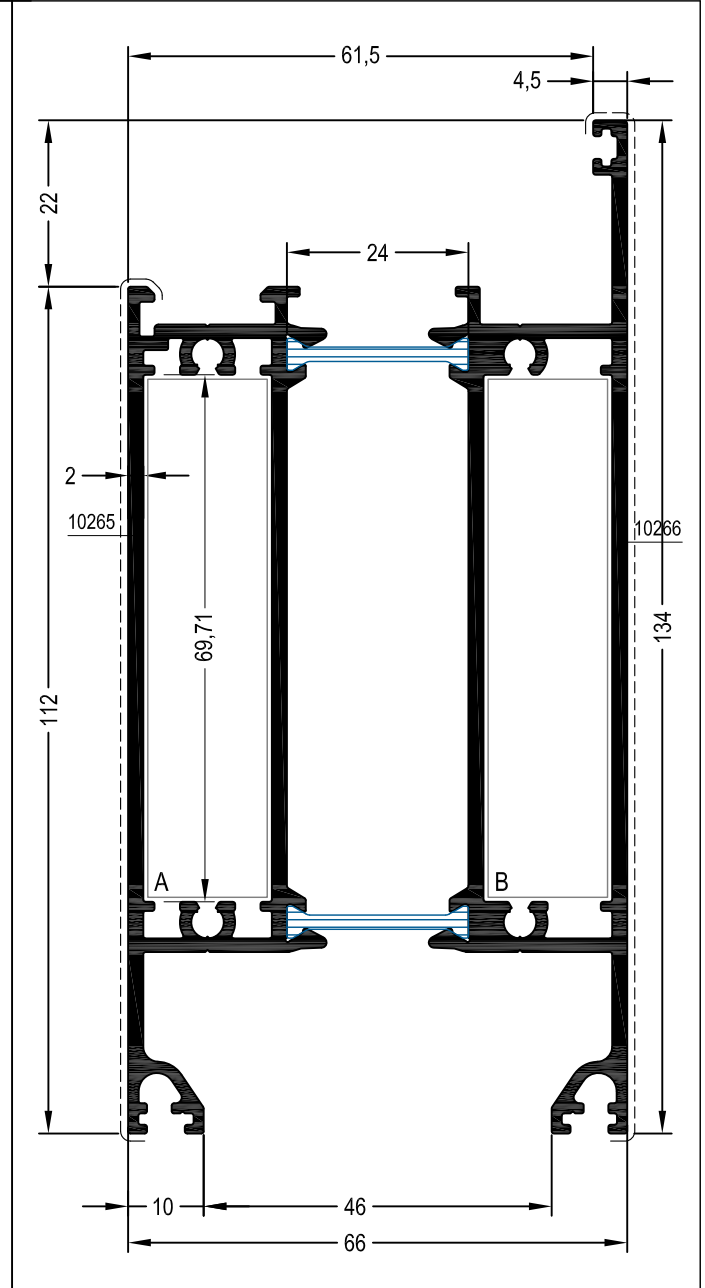
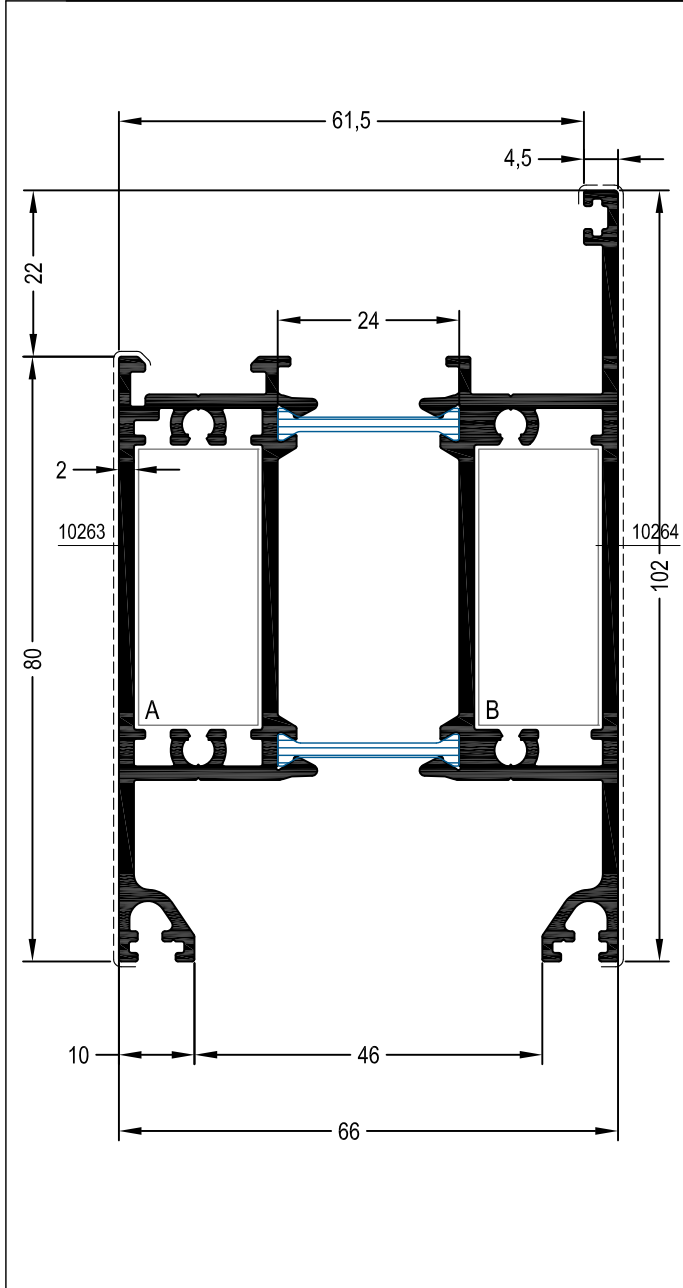

KICK PLATE PROFILE 80 / 102

KICK PLATE PROFILE 112 / 134

PROFILE CODE		19KW01		THEORETICAL WEIGHT kg/mt	
				2.642	
Jxx (cm ⁴)	Jyy (cm ⁴)	Covering Surface (cm)			
		10263	10264		
-----	-----	8.736	11.144		
THERMO BREAK		LOCAL (Pvc)		-----	
T JUNCTION		A	B	C	
		14JW06	14JW07	-----	

PROFILE CODE		19KW02		THEORETICAL WEIGHT kg/mt	
				3.335	
Jxx (cm ⁴)	Jyy (cm ⁴)	Covering Surface (cm)			
		10265	10266		
-----	-----	11.994	14.344		
THERMO BREAK		LOCAL (Pvc)		-----	
T JUNCTION		A	B	C	
		14JW06	14JW07	-----	

KICK PLATE

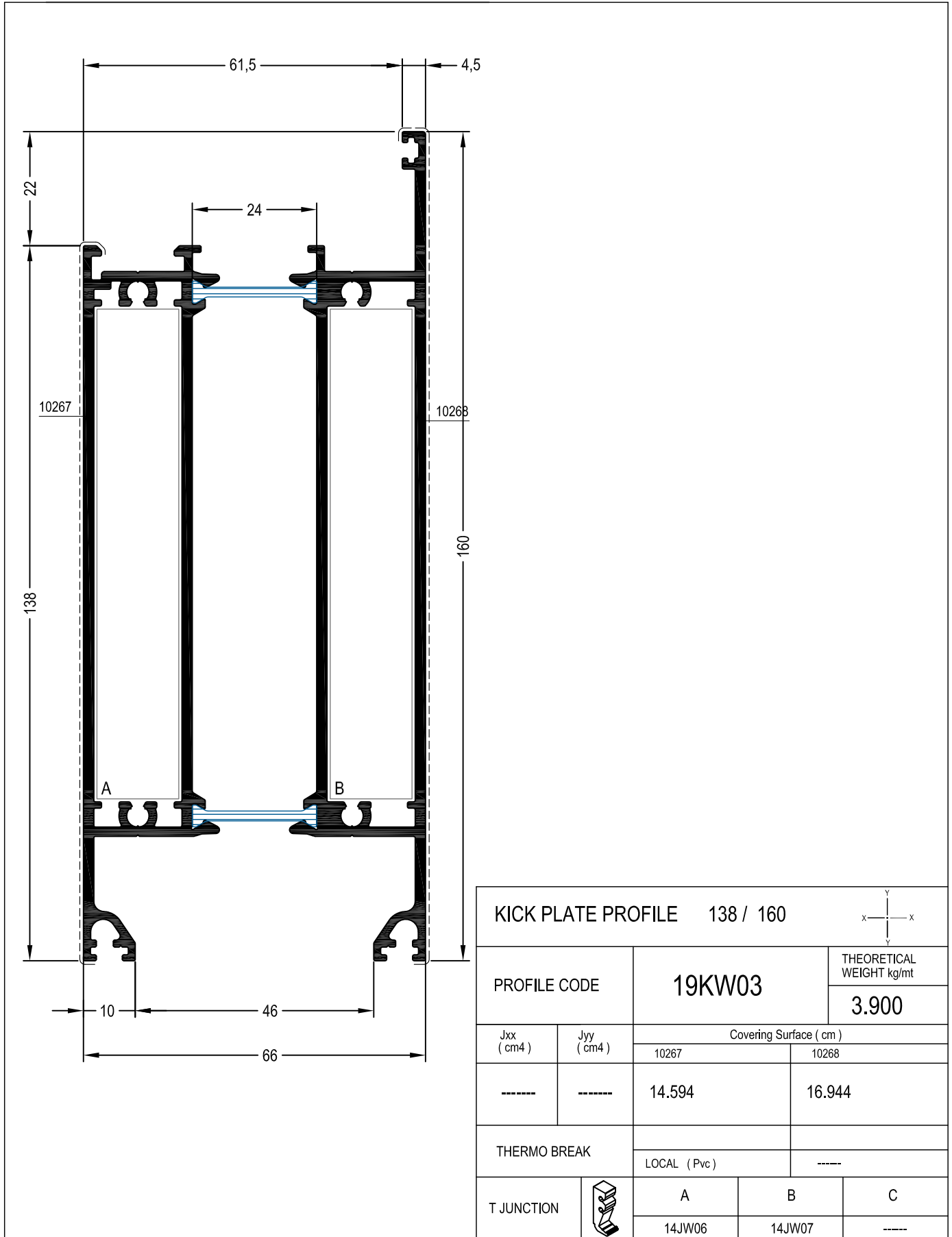

KICK PLATE

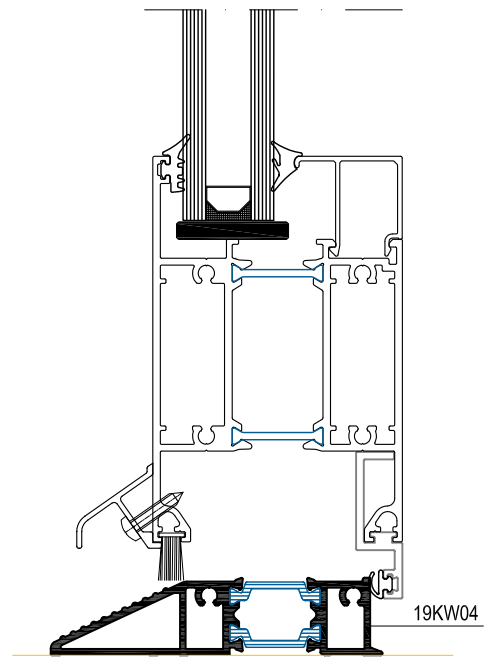
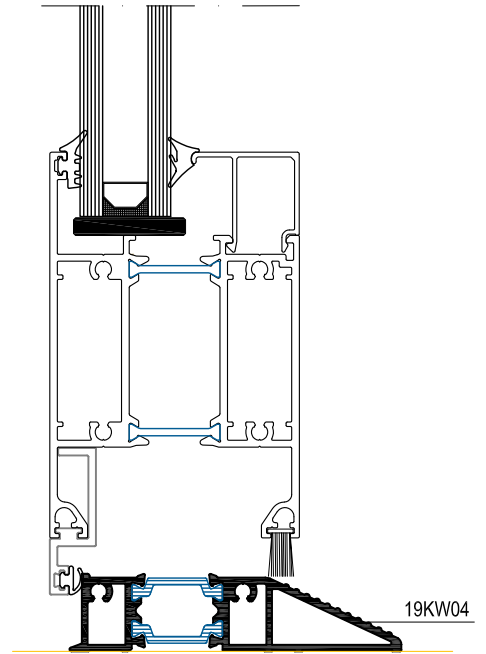
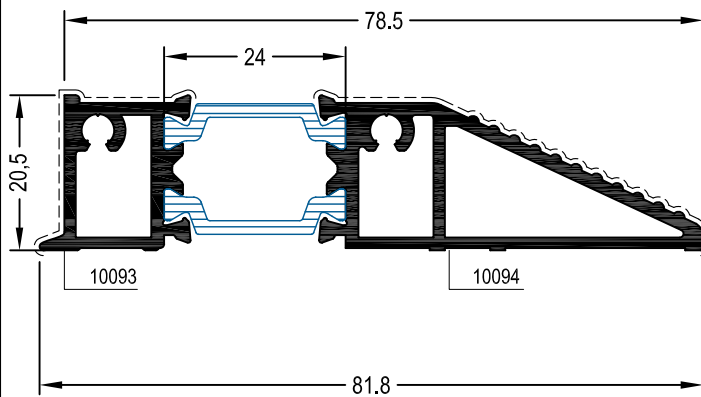

THRESHOLD PROFILE			
PROFILE CODE		19KW04	
		THEORETICAL WEIGHT kg/mt	
		1.219	
Jxx (cm ⁴)	Jyy (cm ⁴)	Covering Surface (cm)	
----	----	10093	10094
----	----	----	----
THERMO BREAK		LOCAL (Pvc)	
APPLICATION PROFILE			
FACE CAP			

KICK PLATE

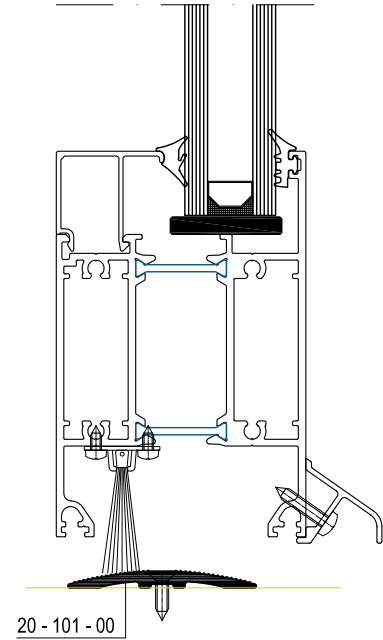
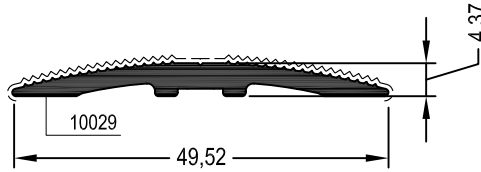

THRESHOLD PROFILE

PROFILE CODE	20 - 101 - 00	THEORETICAL WEIGHT kg/mt	0.355
Coating Surface (cm)	11.405		

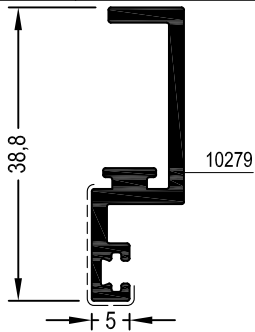

KICK PLATE PROFILE

PROFILE CODE	17AW16	THEORETICAL WEIGHT kg/mt	0.373
Coating Surface (cm)	14.314	Covering Surface (cm)	2.359

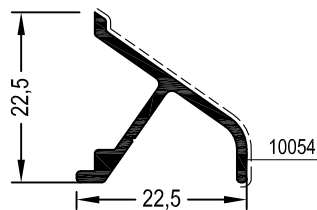

DRAINAGE PROFILE

PROFILE CODE	14PW01	THEORETICAL WEIGHT kg/mt	0.190
Coating Surface (cm)	10.183		

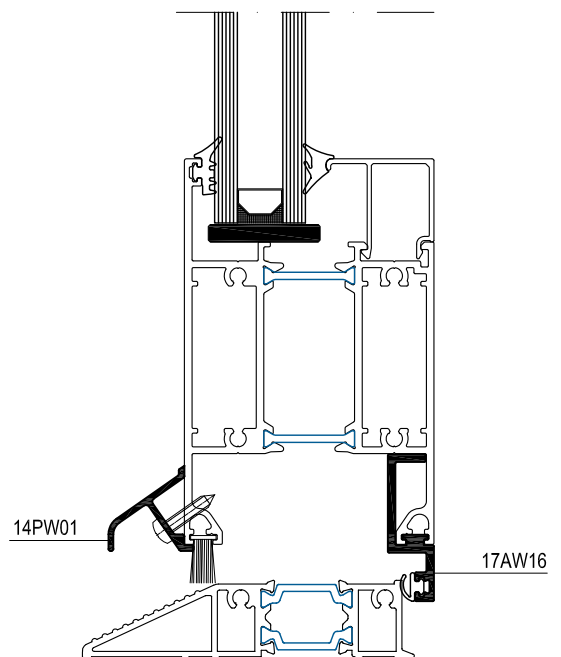

ADAPTERS

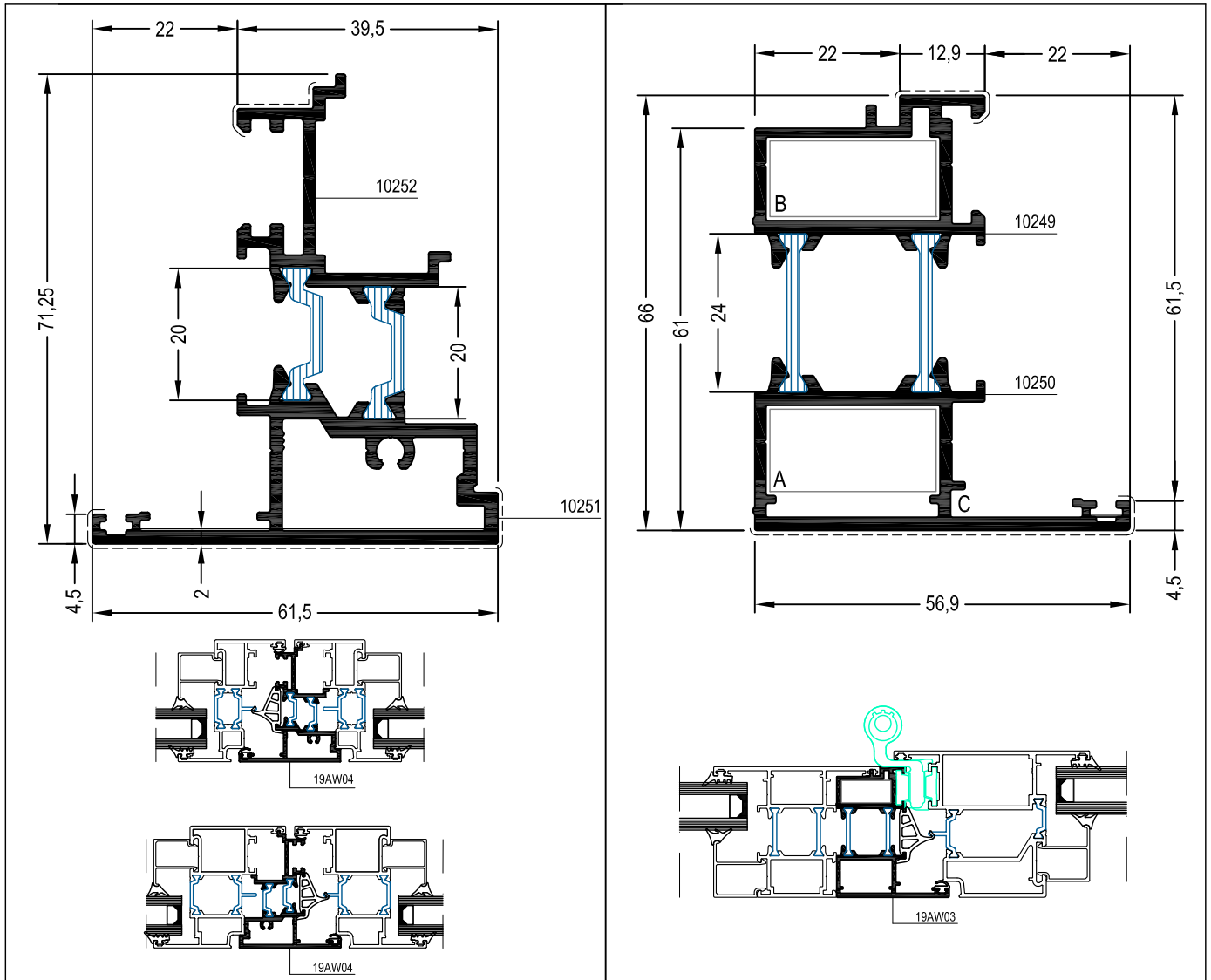

ADAPTER 56.9 / 60



ADAPTER 61.5 / 65.25				PROFILE CODE	19AW03		THEORETICAL WEIGHT kg/mt													
<table border="1"> <tr> <td>PROFILE CODE</td> <td colspan="2">19AW04</td> <td>THEORETICAL WEIGHT kg/mt</td> </tr> <tr> <td>Jxx (cm⁴)</td> <td>Jyy (cm⁴)</td> <td colspan="2">Covering Surface (cm)</td> </tr> <tr> <td>---</td> <td>---</td> <td>10252</td> <td>10251</td> </tr> <tr> <td>---</td> <td>---</td> <td>1.966</td> <td>7.718</td> </tr> </table>				PROFILE CODE	19AW04		THEORETICAL WEIGHT kg/mt	Jxx (cm ⁴)	Jyy (cm ⁴)	Covering Surface (cm)		---	---	10252	10251	---	---	1.966	7.718	1.531
PROFILE CODE	19AW04		THEORETICAL WEIGHT kg/mt																	
Jxx (cm ⁴)	Jyy (cm ⁴)	Covering Surface (cm)																		
---	---	10252	10251																	
---	---	1.966	7.718																	
<table border="1"> <tr> <td>Jxx (cm⁴)</td> <td>Jyy (cm⁴)</td> <td colspan="2">Covering Surface (cm)</td> </tr> <tr> <td>---</td> <td>---</td> <td>10249</td> <td>10250</td> </tr> <tr> <td>---</td> <td>---</td> <td>1.894</td> <td>6.444</td> </tr> </table>		Jxx (cm ⁴)	Jyy (cm ⁴)	Covering Surface (cm)		---	---	10249	10250	---	---	1.894	6.444	THERMO BREAK		LOCAL (Pvc)		---		
Jxx (cm ⁴)	Jyy (cm ⁴)	Covering Surface (cm)																		
---	---	10249	10250																	
---	---	1.894	6.444																	
THERMO BREAK		LOCAL (Pvc)		---	CORNER CLEATS		<table border="1"> <tr> <td>A</td> <td>B</td> <td>C</td> </tr> <tr> <td>14LW32</td> <td>14LW32</td> <td>M.fuji 2000</td> </tr> </table>	A	B	C	14LW32	14LW32	M.fuji 2000							
A	B	C																		
14LW32	14LW32	M.fuji 2000																		
APPLICATION PROFILE		17VW01,17VW02,17VW07		APPLICATION PROFILE		17FW01,17FW02,17FW03,17FW04 17VW05,17VW06														
FACE CAP		TOP	BOTTOM	FACE CAP		TOP	BOTTOM													
		17A1207-T	17A1207-B			-----	-----													

ADAPTERS

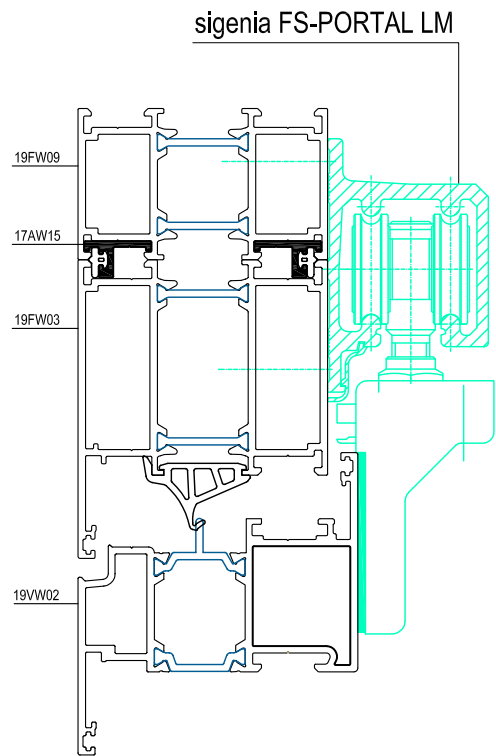
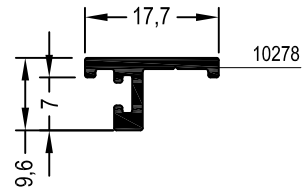
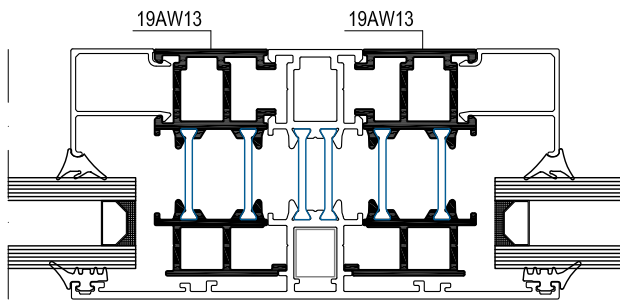
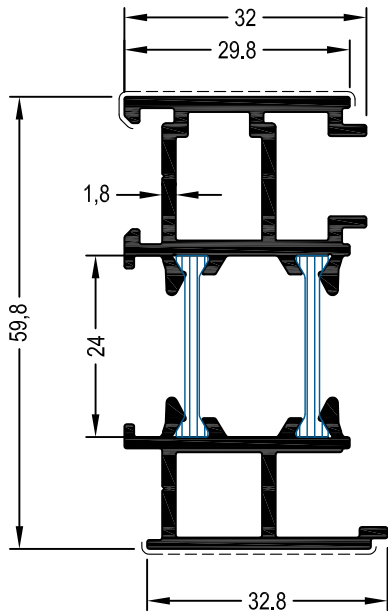

ADAPTER 32 / 53.8



PROFILE CODE

19AW13

THEORETICAL WEIGHT kg/mt

1.267

Jxx (cm⁴)

Jyy (cm⁴)

Covering Surface (cm)

3.616

3.147

THERMO BREAK

IMPORT (Polyamide)

908300 (18 mm I)

LOCAL (Pvc)

APPLICATION PROFILE

ADAPTER 17.7 / 9.6

PROFILE CODE

17AW15

THEORETICAL WEIGHT kg/mt

0.137

Covering Surface (cm)

ADAPTER

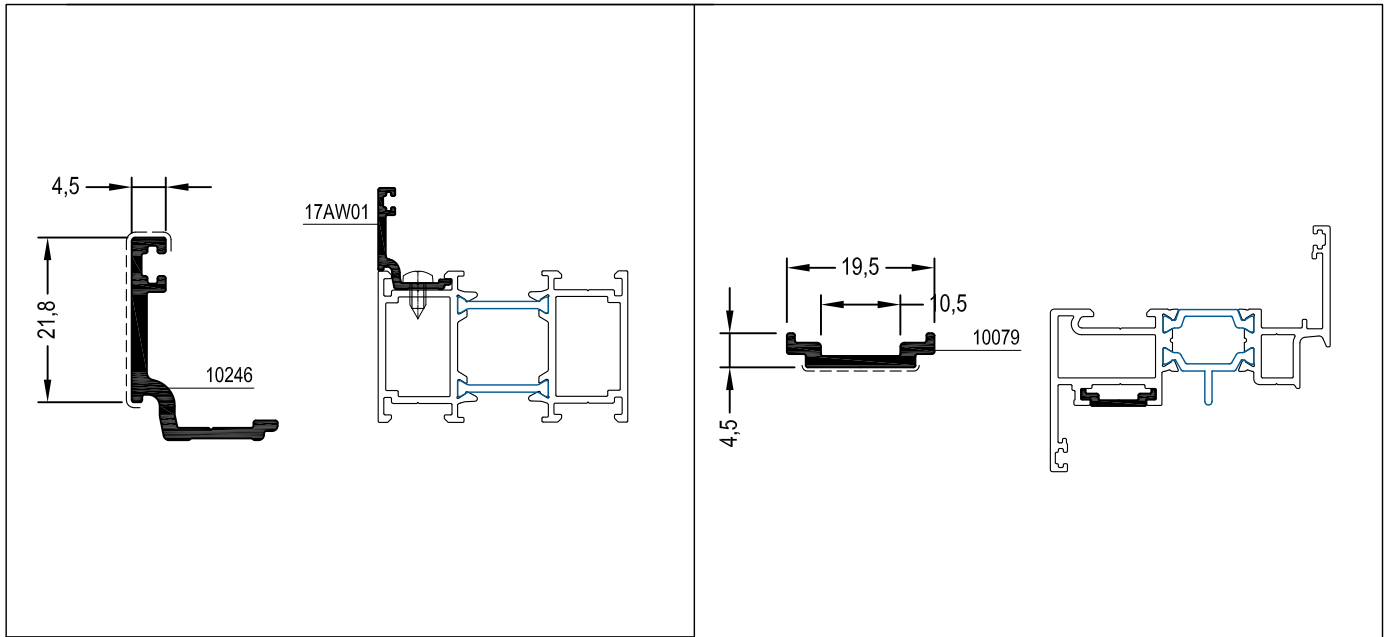

ADAPTER 4,5 / 21.8

PROFILE CODE	17AW01	THEORETICAL WEIGHT kg/mt	SLIDING ROAD PROFILE		
		0.234	PROFILE CODE	14IW01	THEORETICAL WEIGHT kg/mt
Covering Surface (cm)					0.105
3.014					

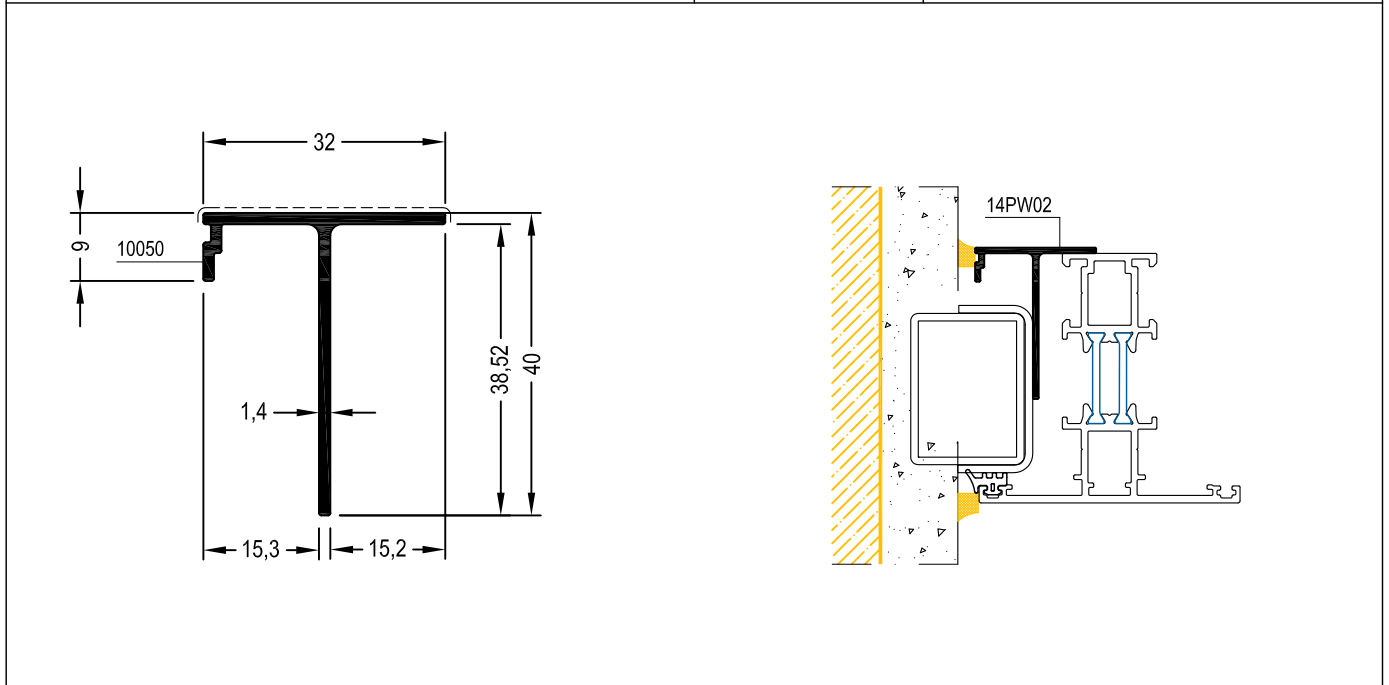

T PROFILE

PROFILE CODE	14PW02	THEORETICAL WEIGHT kg/mt
		0.321
Covering Surface (cm)		
3.508		

ADAPTER

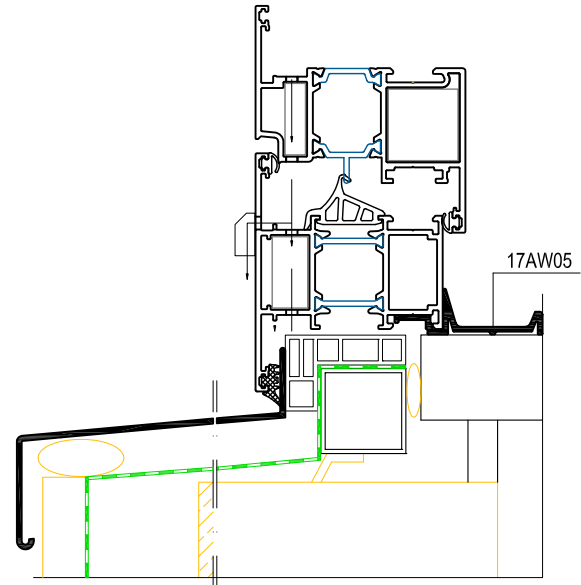
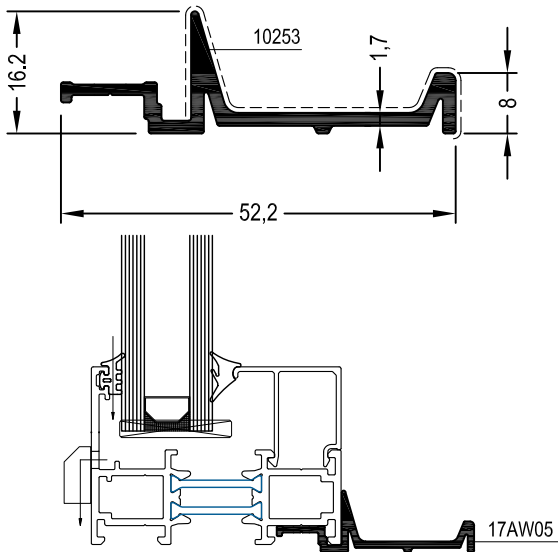

ADAPTER 52.2 / 16.2

PROFILE CODE	17AW05	THEORETICAL WEIGHT kg/mt
		0.407
Covering Surface (cm)		
7.082		

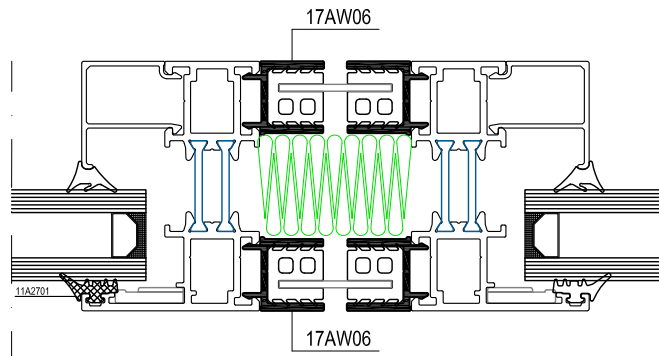
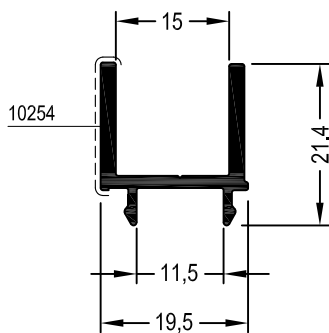

ADAPTER 19.5 / 21.4

PROFILE CODE	17AW06	THEORETICAL WEIGHT kg/mt
		0.278
Covering Surface (cm)		
2.127		

ADAPTER

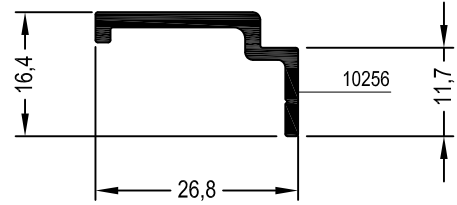
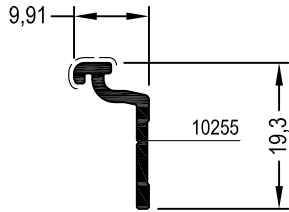

ADAPTER 9.91 / 19.3

ADAPTER 26.8 / 16.4

PROFILE CODE	17AW07	THEORETICAL WEIGHT kg/mt	PROFILE CODE	17AW08	THEORETICAL WEIGHT kg/mt
		0.113			0.221
Covering Surface (cm)			Covering Surface (cm)		
0.880			-----		

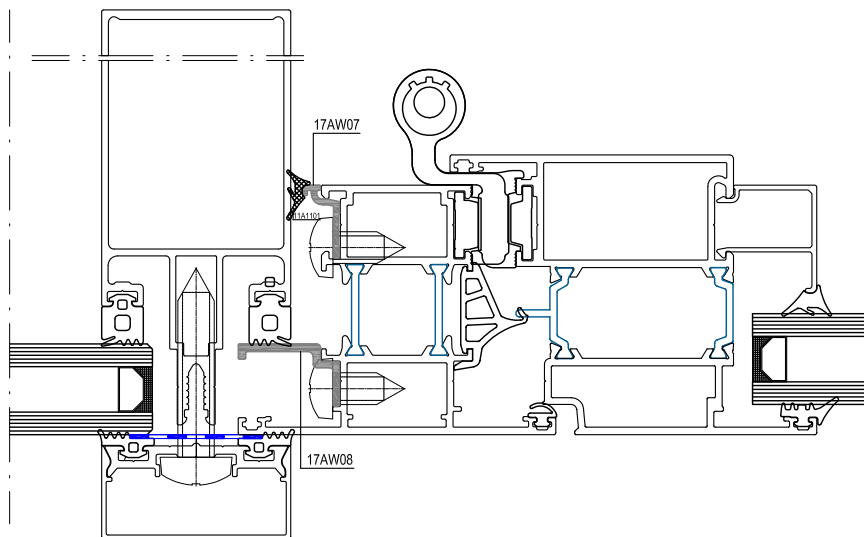

ADAPTER

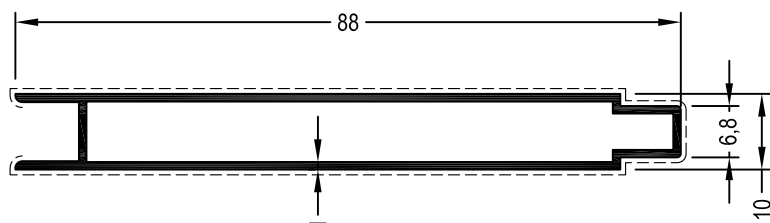

ADAPTER 10 / 88		
PROFILE CODE	1274	THEORETICAL WEIGHT kg/mt
		0.524
Covering Surface (cm)		
16.536		

GLAZING BEAD

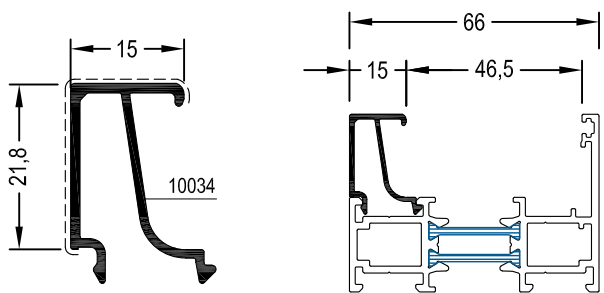
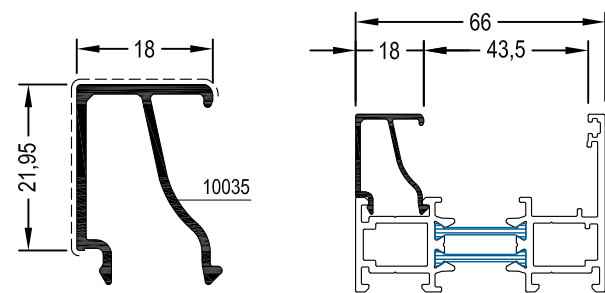
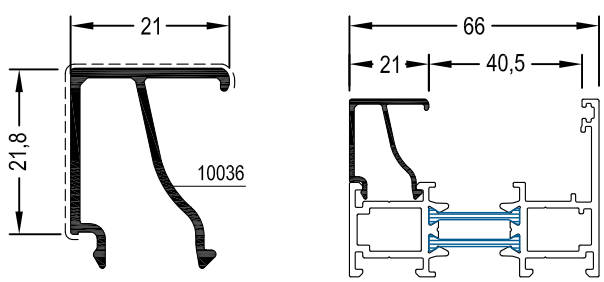
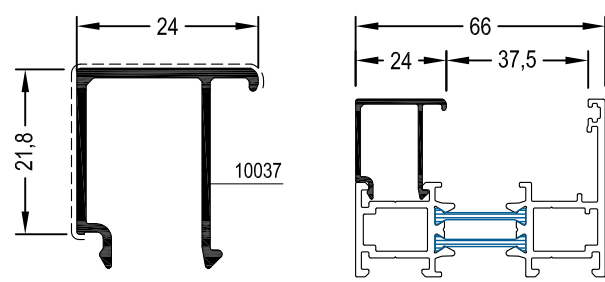
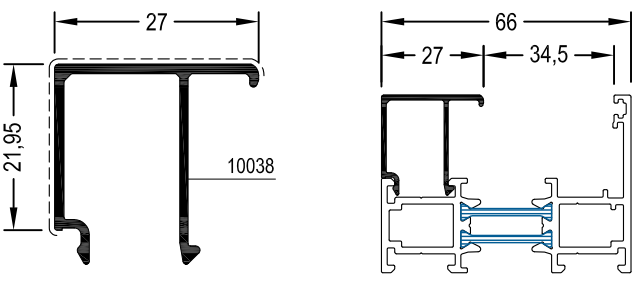
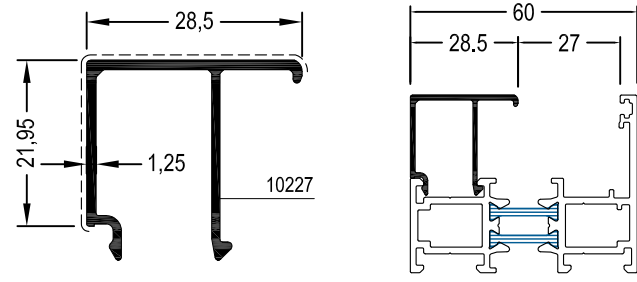
			
GLAZING BEAD 15 / 21.8		GLAZING BEAD 18 / 21.95	
PROFILE CODE	14GW03	THEORETICAL WEIGHT kg/mt	0.245
PROFILE CODE	14GW04	THEORETICAL WEIGHT kg/mt	0.246
Covering Surface (cm)	4.059	Covering Surface (cm)	4.226
			
GLAZING BEAD 21 / 21.8		GLAZING BEAD 24 / 21.8	
PROFILE CODE	14GW05	THEORETICAL WEIGHT kg/mt	0.256
PROFILE CODE	14GW06	THEORETICAL WEIGHT kg/mt	0.260
Covering Surface (cm)	4.569	Covering Surface (cm)	4.959
			
GLAZING BEAD 27 / 21.95		GLAZING BEAD 28.5 / 21.95	
PROFILE CODE	14GW07	THEORETICAL WEIGHT kg/mt	0.270
PROFILE CODE	14GW19	THEORETICAL WEIGHT kg/mt	0.276
Covering Surface (cm)	5.126	Covering Surface (cm)	5.276

GLAZING BEAD

GLAZING BEAD 33 / 21.8			GLAZING BEAD 36 / 21.95		
PROFILE CODE	14GW09	THEORETICAL WEIGHT kg/mt 0.291	PROFILE CODE	14GW10	THEORETICAL WEIGHT kg/mt 0.311
Covering Surface (cm)			Covering Surface (cm)		
5.830			6.026		

CORNER CLEATS

* pressed profile				* pressed profile			
CORNER CLEATS		26.1 / 60		CORNER CLEATS		11.1 / 55	
PROFILE CODE	14LW32	PRES	THEORETICAL WEIGHT kg/mt	PROFILE CODE	14LW14	PRES	THEORETICAL WEIGHT kg/mt
			3.363				2.154
APPLICATION PROFILE	PROFILE CODE			APPLICATION PROFILE	PROFILE CODE		
	19FW02 , 19FW09 , 19FW06				19FW01 , 19FW05 , 19FW08		
	19MW02				19MW01 , 19VW01 , 19VW07 , 19VW08		

CORNER CLEATS

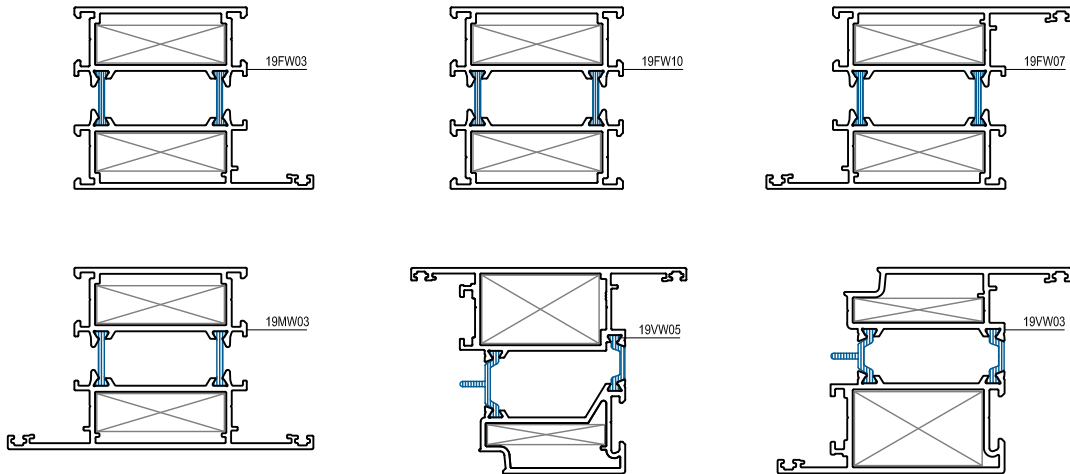
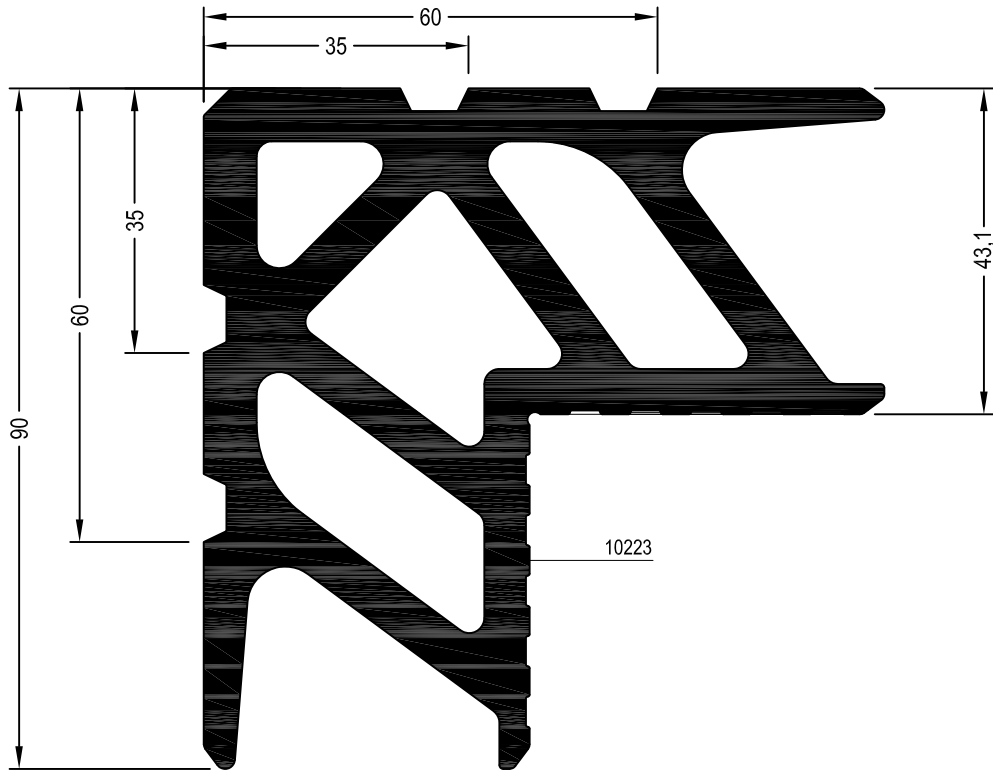

CORNER CLEATS		43.1 / 90	
PROFILE CODE	14LW33	PRES	THEORETICAL WEIGHT kg/mt
			7.344
APPLICATION PROFILE		PROFILE CODE	
		19FW03 , 19FW07 , 19FW10	
		19MW03 , 19VW05 , 19VW03	

CORNER CLEATS

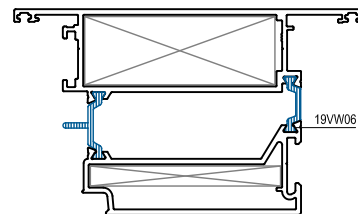
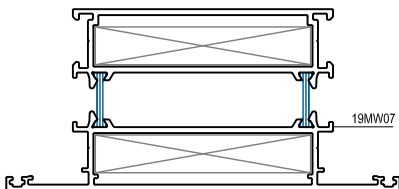
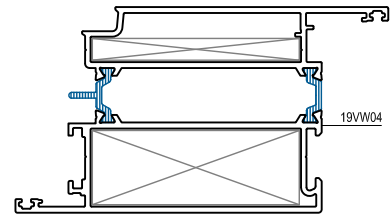
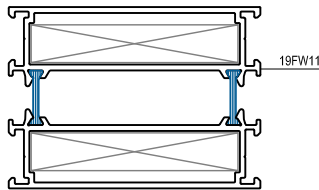
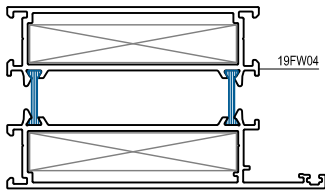
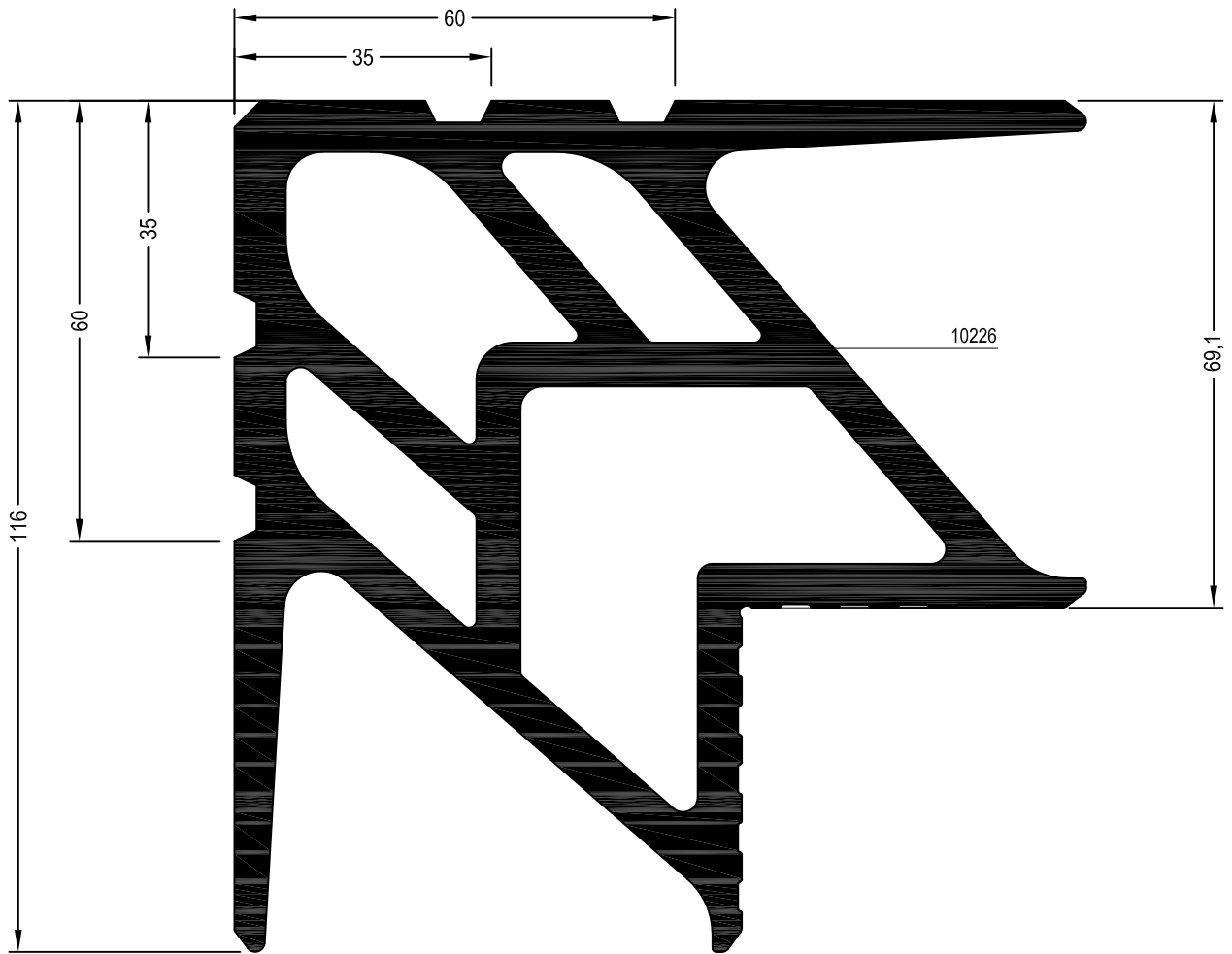

CORNER CLEATS		69.1 / 116	
PROFILE CODE	14LW34	PRES	THEORETICAL WEIGHT kg/mt
			10.235
APPLICATION PROFILE		PROFILE CODE	
		19FW04, 19FW11	
		19MW07, 19VW04, 19VW06	

CORNER CLEATS

<p>10105</p>				<p>10584</p>			
<p>19VW11</p>				<p>19AW18, 19AW17</p>			
* pressed profile				* pressed profile			
CORNER CLEATS		19.5 / 65		CORNER CLEATS		15 / 60	
PROFILE CODE	14LW35	PRES	THEORETICAL WEIGHT kg/mt	PROFILE CODE	14LW13	THEORETICAL WEIGHT kg/mt	
			4.270			2.488	
APPLICATION PROFILE		PROFILE CODE		APPLICATION PROFILE		PROFILE CODE	
		19VW11				19AW17, 19AW18	

CORNER CLEATS

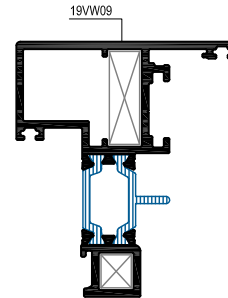
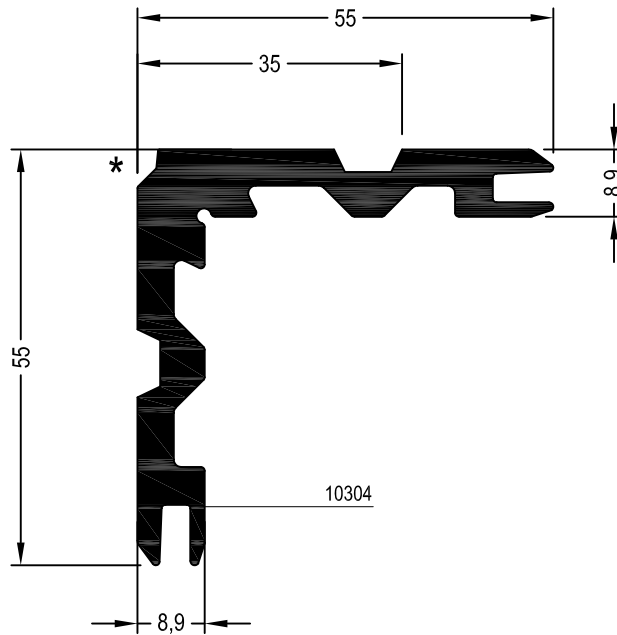

* pressed profile

CORNER CLEATS		8.9 / 55	
PROFILE CODE	14LW45	PRES	THEORETICAL WEIGHT kg/mt
			1.672
APPLICATION PROFILE	PROFILE CODE		
	19VW09		

T JUNCTION

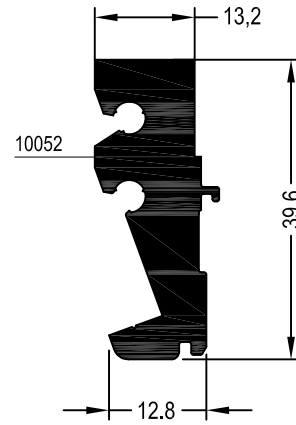
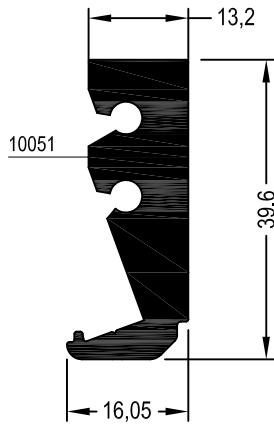

T JUNCTION 13.2 / 39.6

T JUNCTION 13.2 / 39.6

PROFILE CODE	14JW04	PRES	THEORETICAL WEIGHT kg/mt	PROFILE CODE	14JW05	PRES	THEORETICAL WEIGHT kg/mt
			1.056				1.056

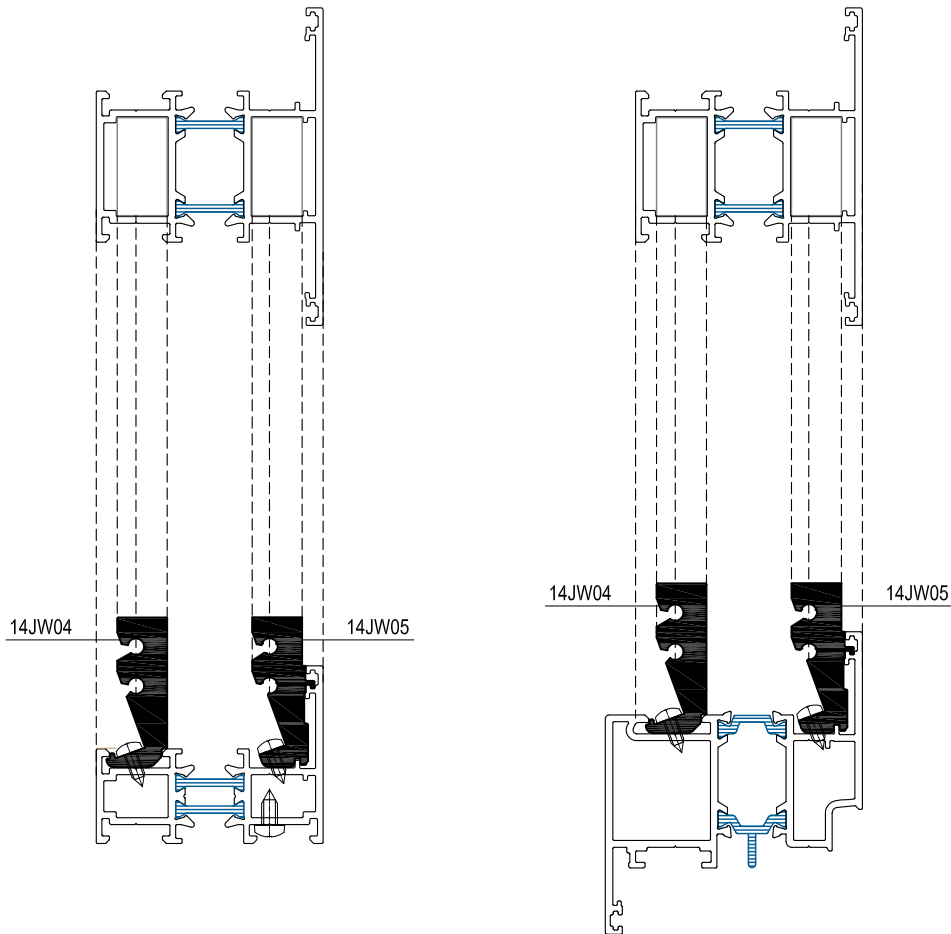

T JUNCTION

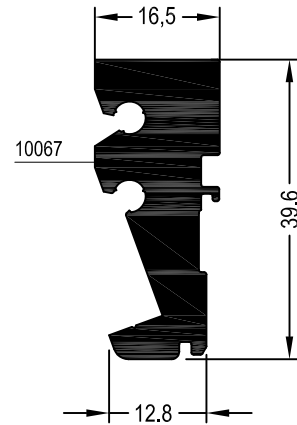
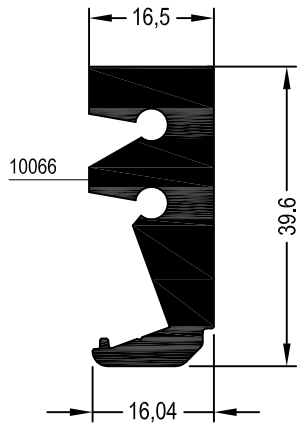

T JUNCTION 16.5 / 39.6

T JUNCTION 16.5 / 39.6

PROFILE CODE	14JW06	PRES	THEORETICAL WEIGHT kg/mt	PROFILE CODE	14JW07	PRES	THEORETICAL WEIGHT kg/mt
			1.164				1.170

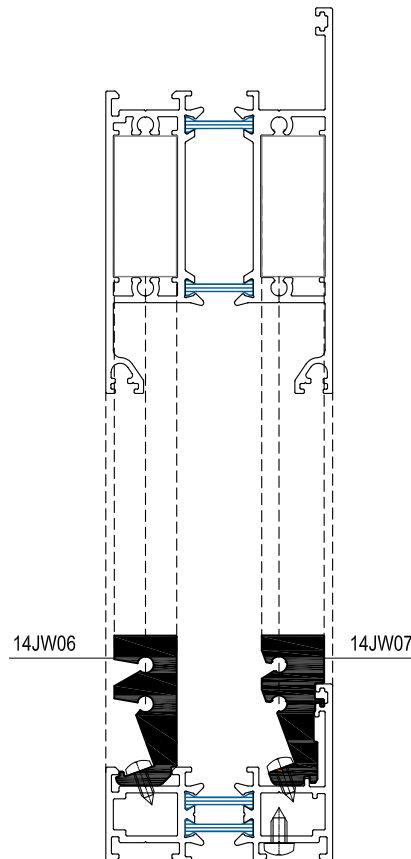

SILL PROFILE

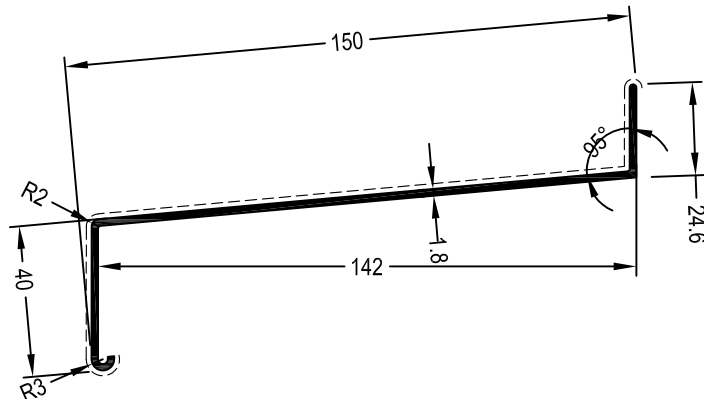

SILL PROFILE		40 / 150
PROFILE CODE	6707	THEORETICAL WEIGHT kg/mt
		1.011

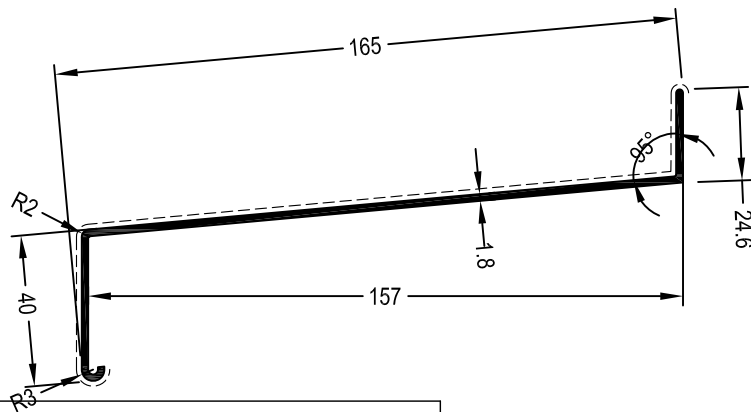

SILL PROFILE		40 / 165
PROFILE CODE	6706	THEORETICAL WEIGHT kg/mt
		1.084

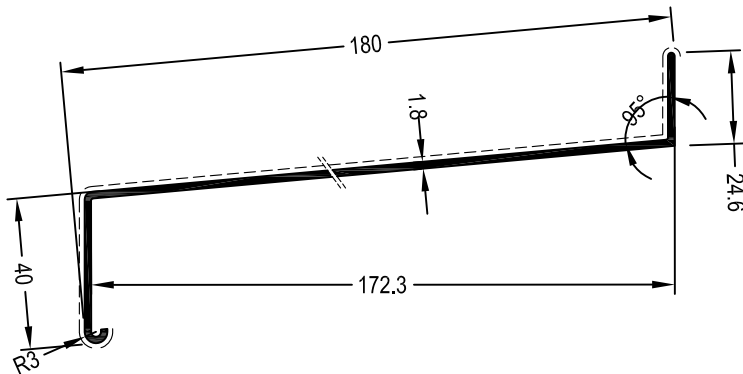

SILL PROFILE		40 / 180
PROFILE CODE	6705	THEORETICAL WEIGHT kg/mt
		1.157

SILL PROFILE

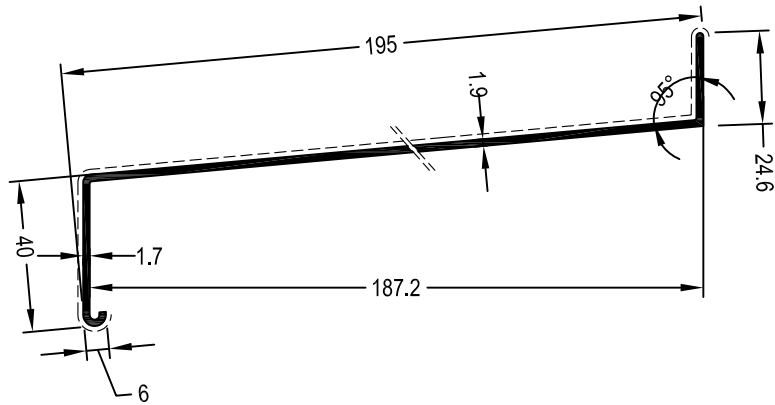

SILL PROFILE	40 / 195	
PROFILE CODE	6704	THEORETICAL WEIGHT kg/mt
		1.292

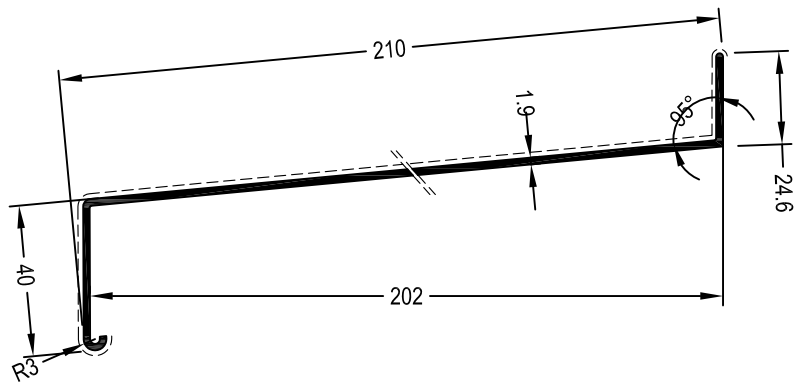

SILL PROFILE	40 / 210	
PROFILE CODE	6703	THEORETICAL WEIGHT kg/mt
		1.589

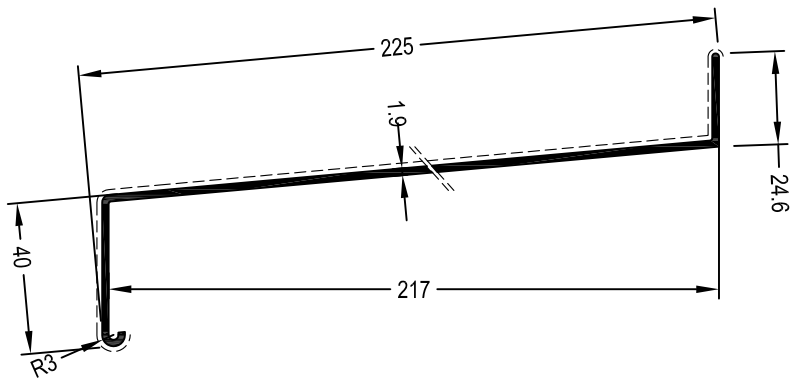

SILL PROFILE	40 / 225	
PROFILE CODE	6702	THEORETICAL WEIGHT kg/mt
		1.446

SILL PROFILE

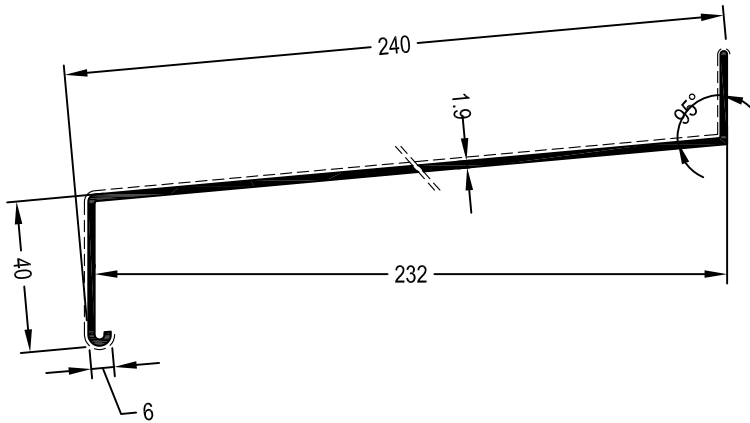

SILL PROFILE		40 / 240	
PROFILE CODE	6701	THEORETICAL WEIGHT kg/mt	
		1.522	

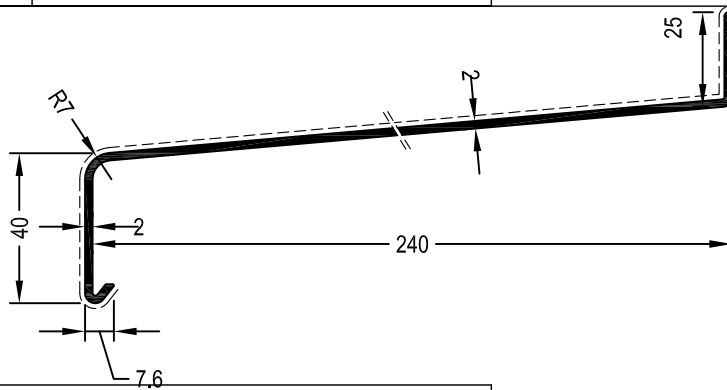

SILL PROFILE		40 / 240	
PROFILE CODE	6711	THEORETICAL WEIGHT kg/mt	
		1.645	

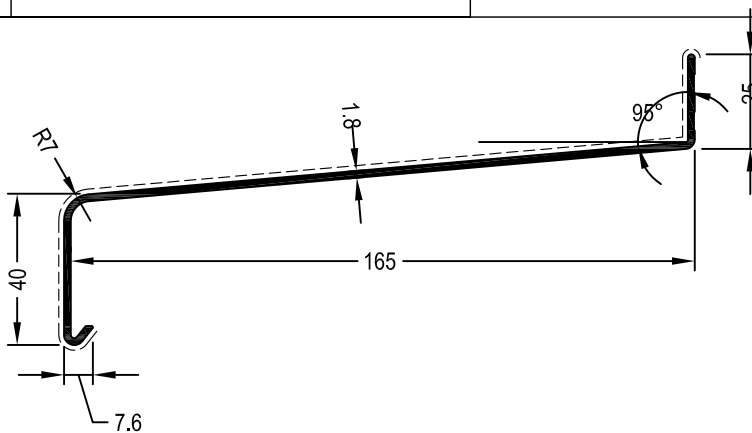

SILL PROFILE		40 / 165	
PROFILE CODE	6712	THEORETICAL WEIGHT kg/mt	
		1.119	

c - ACCESSORIES

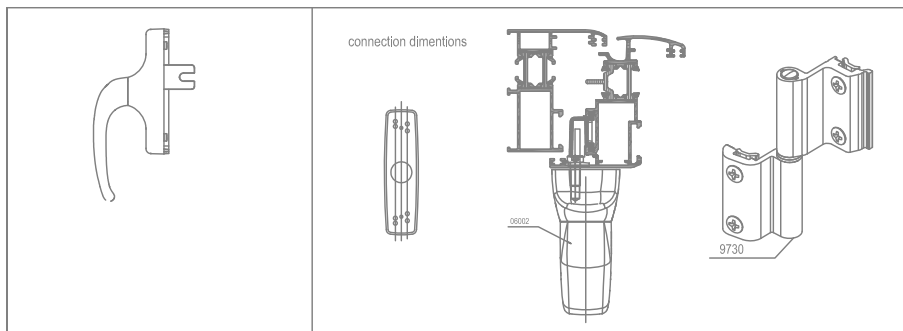

E.P.D.M. GASKETS

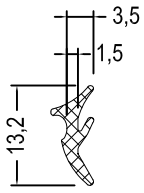
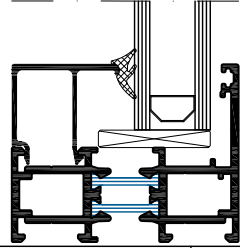
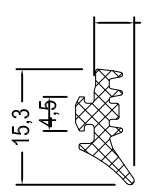
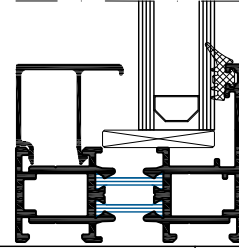
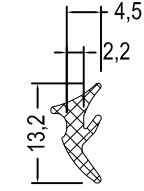
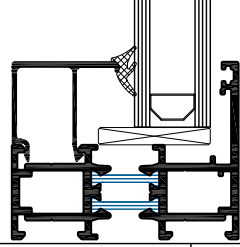
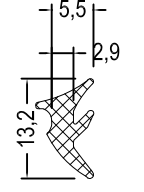
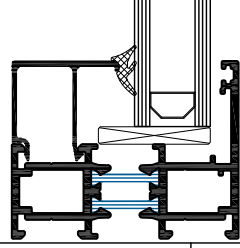
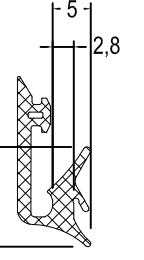
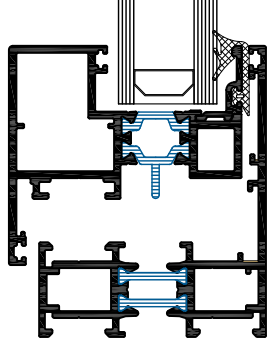
					
11A1101	Glazing Gasket Inside 300 m in one package	THEORETICAL WEIGHT kg/mt 0.050 kg/mt	11A2701	Glazing Gasket Outside 270 m in one package	THEORETICAL WEIGHT kg/mt 0.055 kg/mt
MATERIALS	E.P.D.M.		MATERIALS	E.P.D.M.	
					
11A1102	Glazing Gasket Inside 250 m in one package	THEORETICAL WEIGHT kg/mt 0.060 kg/mt			
MATERIALS	E.P.D.M.				
					
11A1103	Glazing Gasket Inside 215 m in one package	THEORETICAL WEIGHT kg/mt 0.070 kg/mt			
MATERIALS	E.P.D.M.				
					
11A1104	Glazing Gasket Inside 158 m in one package	THEORETICAL WEIGHT kg/mt 0.095 kg/mt			
MATERIALS	E.P.D.M.				

E.P.D.M. GASKETS

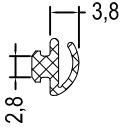
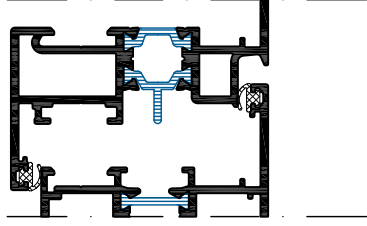
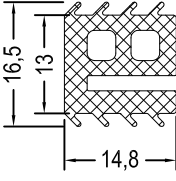
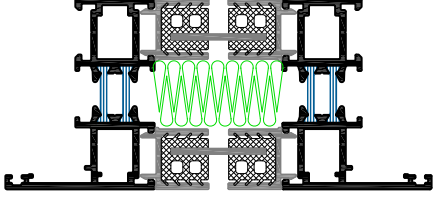
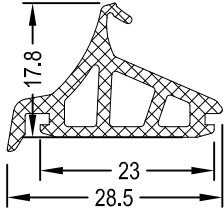
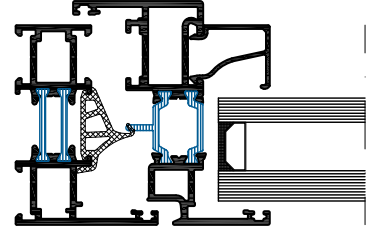
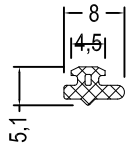
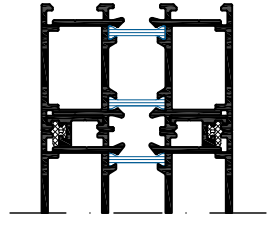
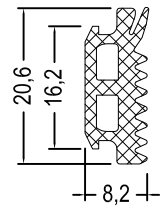
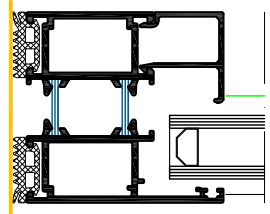
			
<p>11A1301</p>	<p>Acoustical Gasket</p> <p>375 m in one package</p> <p>THEORETICAL WEIGHT kg/mt</p> <p>0.040 kg/mt</p>	<p>11A1706</p>	<p>Gaskets for Adapter Profile</p> <p>73 m in one package</p> <p>THEORETICAL WEIGHT kg/mt</p> <p>0.205 kg/mt</p>
<p>MATERIALS</p>	<p>E.P.D.M.</p>	<p>MATERIALS</p>	<p>E.P.D.M.</p>
			
<p>11A1406</p>	<p>Central Gasket</p> <p>79 m in one package</p> <p>THEORETICAL WEIGHT kg/mt</p> <p>0.190 kg/mt</p>	<p>11A1502</p>	<p>Gaskets for Adapter Profile</p> <p>517 m in one package</p> <p>THEORETICAL WEIGHT gr/mt</p> <p>0.029 kg/mt</p>
<p>MATERIALS</p>	<p>E.P.D.M.</p>	<p>MATERIALS</p>	<p>E.P.D.M.</p>
			
		<p>11A1503</p>	<p>Gaskets for Adapter Profile</p> <p>128 m in one package</p> <p>THEORETICAL WEIGHT kg/mt</p> <p>0.155 kg/mt</p>
		<p>MATERIALS</p>	<p>E.P.D.M.</p>

CORNER CLEATS

DRAWING / INFORMATION

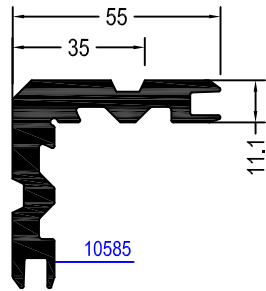

* pressed profile

CORNER CLEATS WITH PRES 11.1 / 55

PROFILE CODE	14LW14	PRES	THEORETICAL WEIGHT kg/mt
			2.154
APPLICATION PROFILES	Cutting Sizes (mm)	PIECE CODE NUMBER	
19FW01	10200 10201	13.3 mm	-----
19FW05	10200	13.3 mm	-----
19FW08	10201 10201	13.3 mm	-----
19FW13	10201 10272	13.3 mm	-----
19VW01	10207 10206	8.0 mm 25.4 mm	-----
19VW07	10228 10224	8.4 mm 26.0 mm	-----
19VW08	10209 10243	----- 25.4 mm	-----
19MW01	10201 10225	13.3 mm	-----
19MW14	10201 x1	13.3 mm	-----

APPLICATION

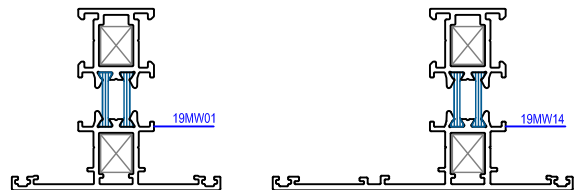
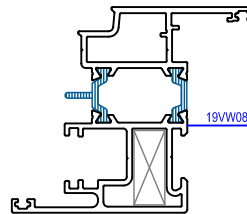
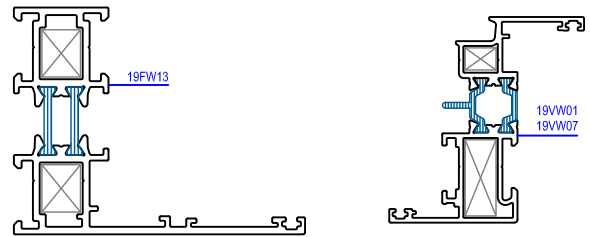
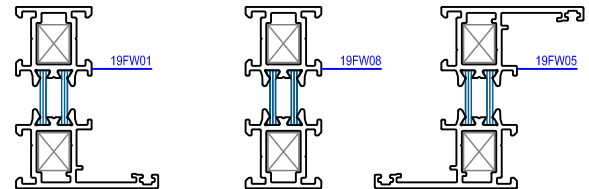

CORNER CLEATS

DRAWING / INFORMATION

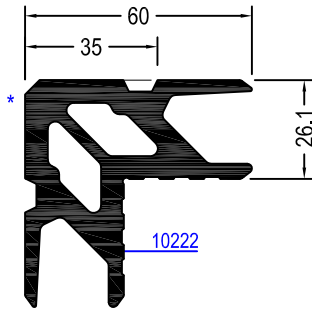

* pressed profile

CORNER CLEATS WITH PRES 26.1 / 60

PROFILE CODE	14LW32	PRES	THEORETICAL WEIGHT kg/m
			3.363
APPLICATION PROFILES	Cutting Sizes (mm)	PIECE CODE NUMBER	
19FW02	10203	13.3 mm	-----
	10202		-----
19FW06	10202	13.3 mm	-----
	10202		-----
19FW09	10203	13.3 mm	-----
	10203		-----
19VW02	10209	8.0 mm	-----
	10208	25.4 mm	-----
19VW08	10209	8.0 mm	-----
	10243	-----	-----
19VW11	10209	8.0 mm	-----
	10280	-----	-----
19MW02	10203	13.3 mm	-----
	10214		-----
19AW03	10249	12.3 mm	-----
	10250	13.3 mm	-----

APPLICATION

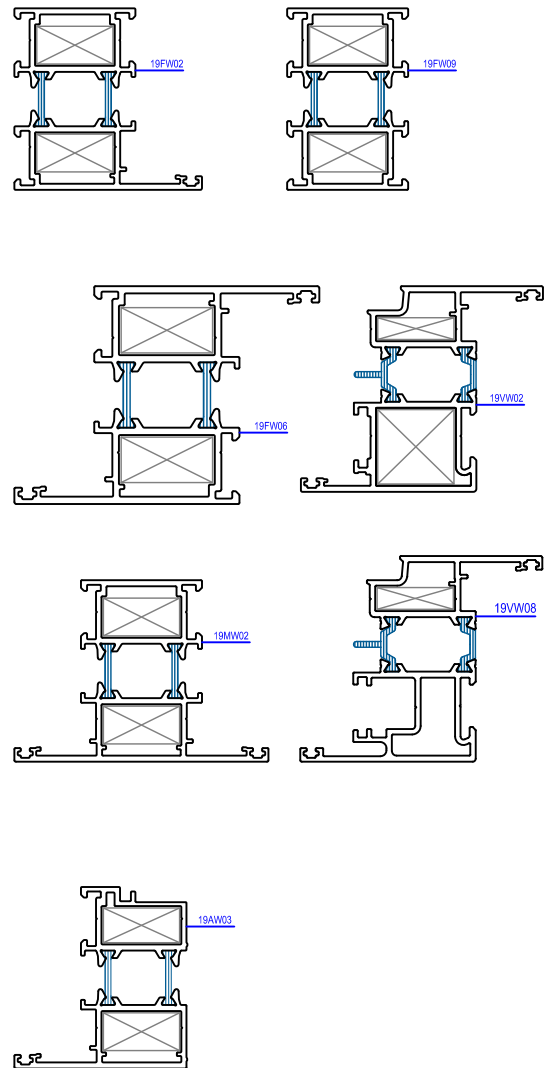

CORNER CLEATS

DRAWING / INFORMATION

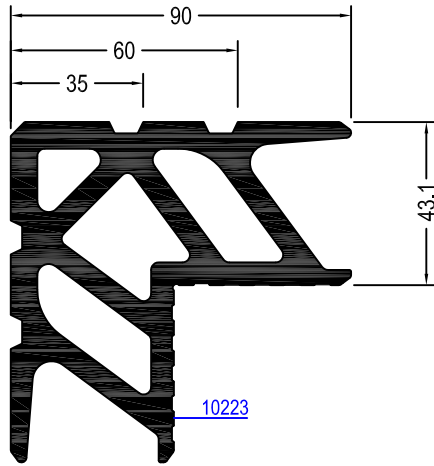

* pressed profile

CORNER CLEATS WITH PRES 43.1 / 90

PROFILE CODE	14LW33	PRES	THEORETICAL WEIGHT kg/mt
			7.344

APPLICATION PROFILES		Cutting Sizes (mm)	PIECE CODE NUMBER 
19FW03	10205	13.3 mm	-----
	10204		-----
19FW07	10204	13.3 mm	-----
	10204		-----
19FW10	10205	13.3 mm	-----
	10205		-----
19VW03	10211	8.0 mm	-----
	10210	25.4 mm	-----
19VW05	10240	25.4 mm	-----
	10239	8.0 mm	-----
19MW03	10205	13.3 mm	-----
	10215		-----

APPLICATION

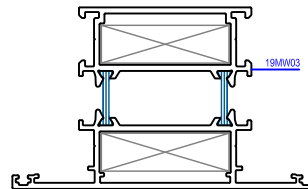
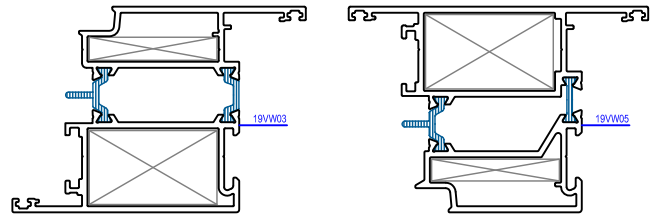
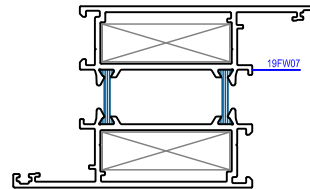
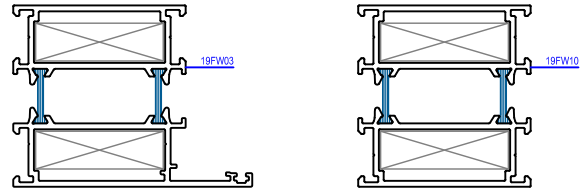

CORNER CLEATS

DRAWING / INFORMATION

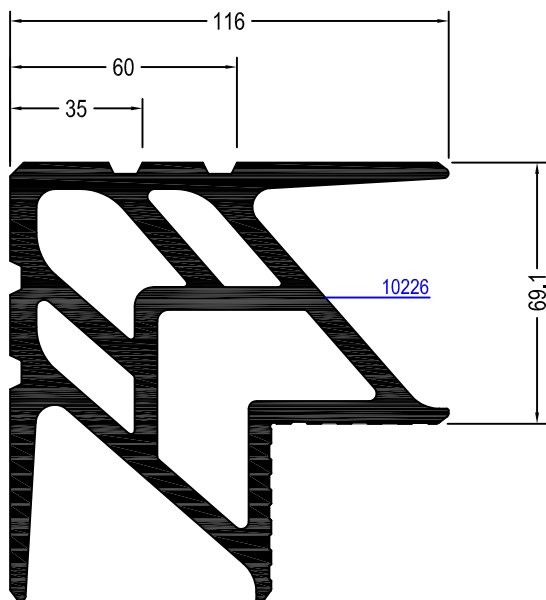

* pressed profile

APPLICATION

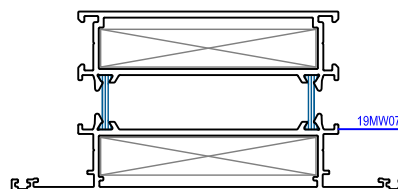
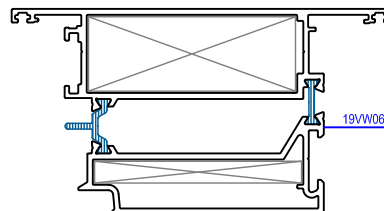
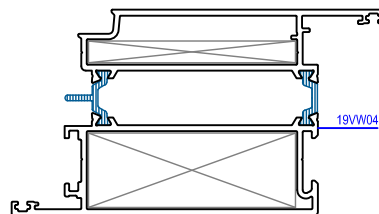
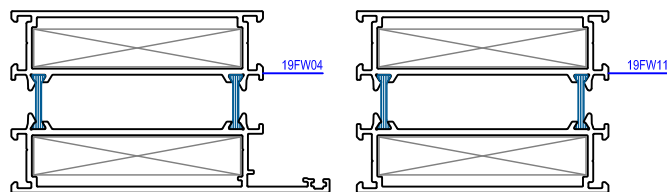

CORNER CLEATS WITH PRES 69.1 / 116

PROFILE CODE	14LW34	PRES	THEORETICAL WEIGHT kg/mt
			10.235
APPLICATION PROFILES	Cutting Sizes (mm)	PIECE CODE NUMBER	
19FW04	10230	13.3 mm	-----
	10231		
19FW11	10230	13.3 mm	-----
	10230		
19VW04	10213	8.0 mm	-----
	10212	25.4 mm	-----
19VW06	10242	25.4 mm	-----
	10241	8.0 mm	-----
19MW07	10244	13.3 mm	-----
	10245		

CORNER CLEATS

DRAWING / INFORMATION

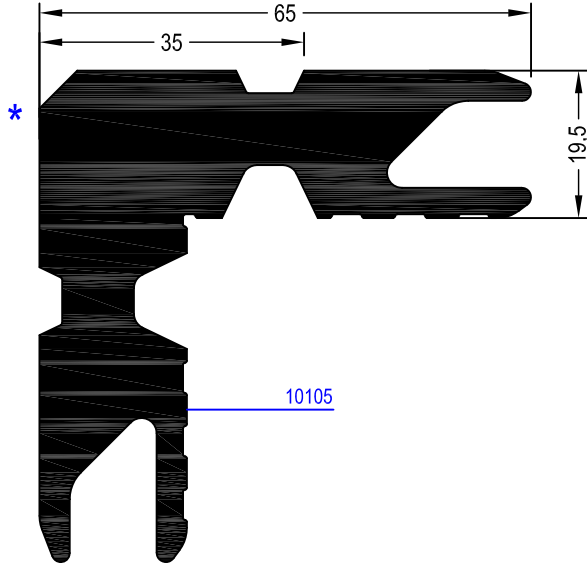

10105

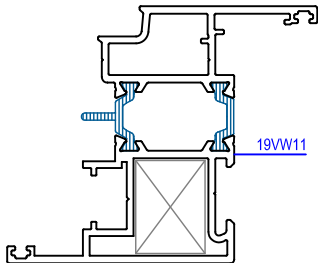

19VW11

* pressed profile

APPLICATION

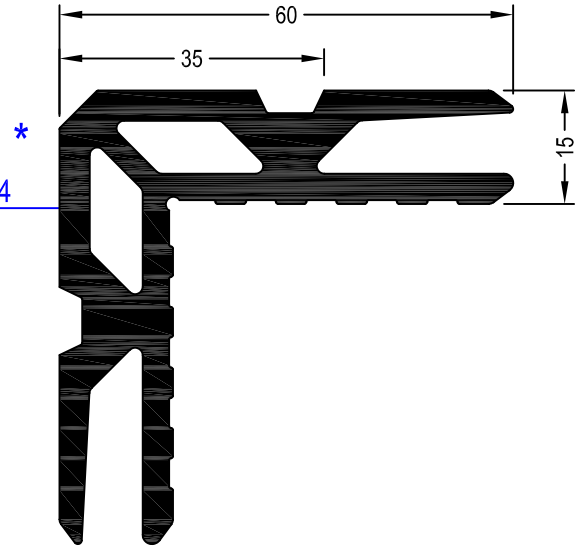

10584

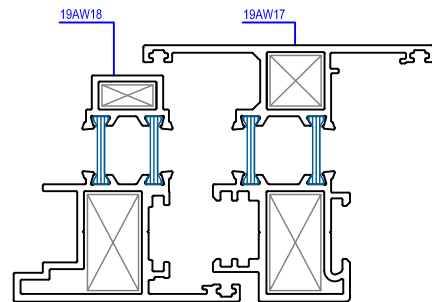

19AW18

19AW17

* pressed profile

CORNER CLEATS WITH PRES 15 / 60

CORNER CLEATS WITH PRES 19.5 / 65

PROFILE CODE		14LW35	PRES	THEORETICAL WEIGHT kg/mt	PROFILE CODE	14LW13	PRES	THEORETICAL WEIGHT kg/mt
				4.270				2.488
APPLICATION PROFILES		Cutting Sizes (mm)		PIECE CODE NUMBER	APPLICATION PROFILES		Cutting Sizes (mm)	
19VW11	10209	-----		-----	19AW17	10296	14.8 mm	
	10280	25.4 mm		-----		10297	26.8 mm	
					19AW18	10298	26.8 mm	
						10299	7.0 mm	

CORNER CLEATS

DRAWING / INFORMATION

APPLICATION

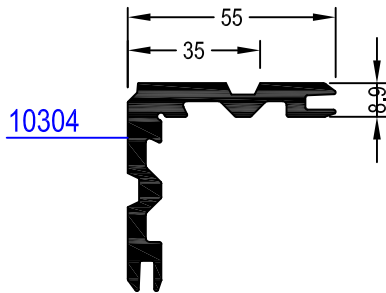

* pressed profile

CORNER CLEATS WITH PRES 08.9 / 55

PROFILE CODE	14LW45	PRES	THEORETICAL WEIGHT kg/mt
			1.672
APPLICATION PROFILES		Cutting Sizes (mm)	PIECE CODE NUMBER 
19VW09	10270	09.5 mm	-----
	10271	25.4 mm	-----

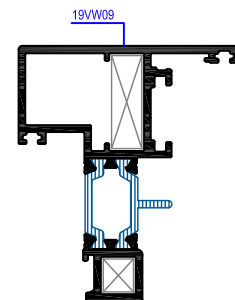

CORNER CLEATS

DRAWING / INFORMATION

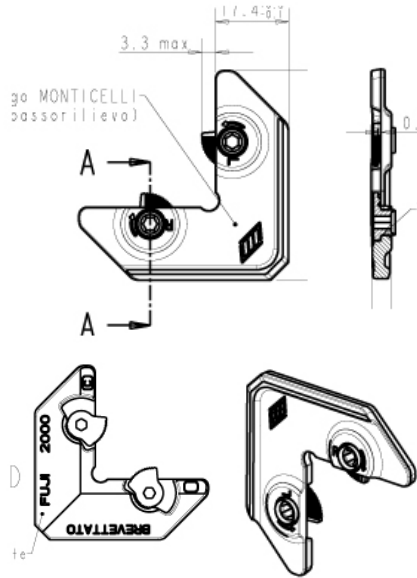

APPLICATION

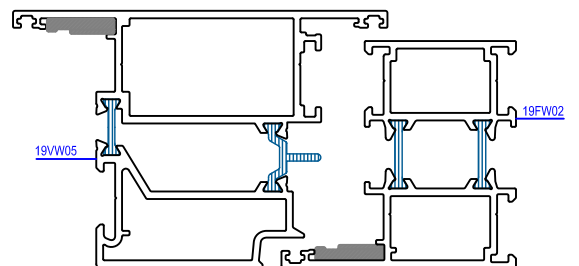
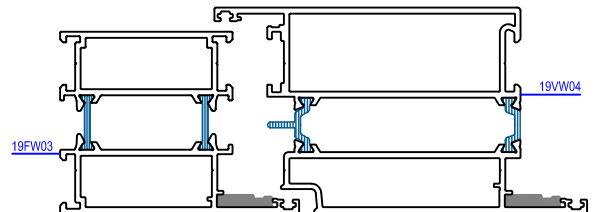
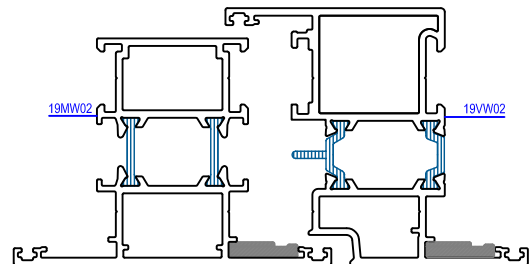
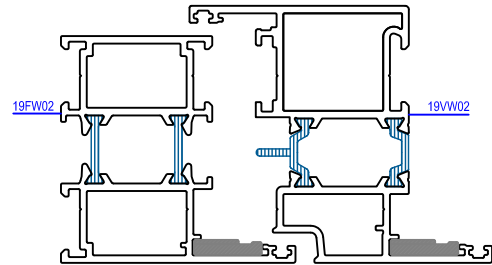
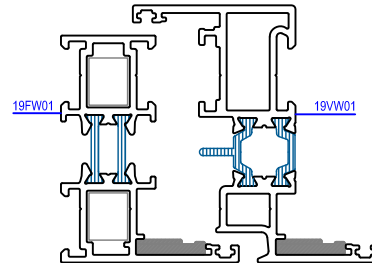

CODE FUJI 2000 Aluminium Corner Joint with nut

APPLICATION PROFILES

- 17FW01,17FW02,17FW03,17FW04,17FW05,17FW06
- 17FW07,17FW12,17FW13,17FW14
- 17VW01,17VW02,17VW03,17VW04,17VW05,17VW06
- 17VW07,17VW08
- 17MW01,17MW02,17MW03,17MW07

MATERIALS

Die -Cast Corner Joint

CORNER CLEATS

DRAWING / INFORMATION

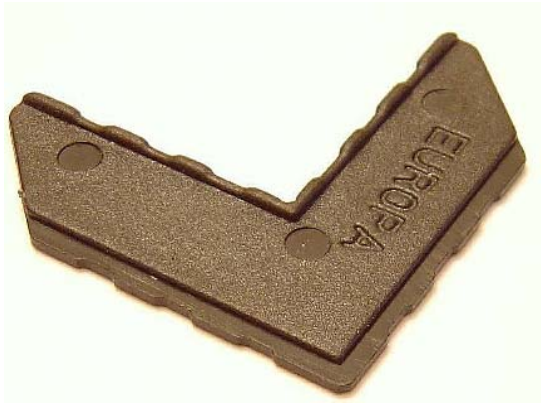

APPLICATION

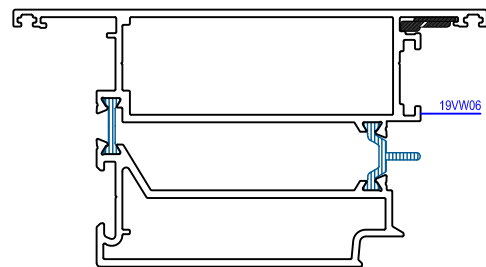
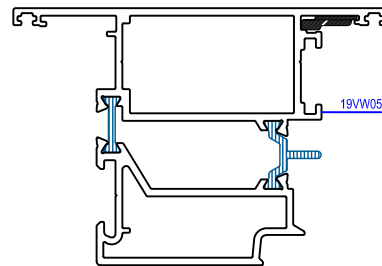
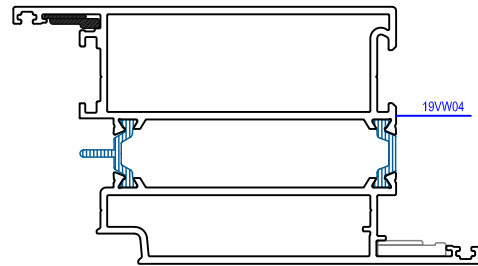
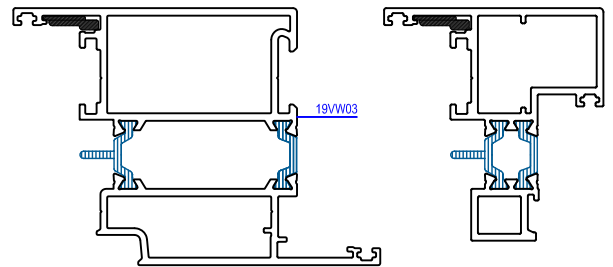
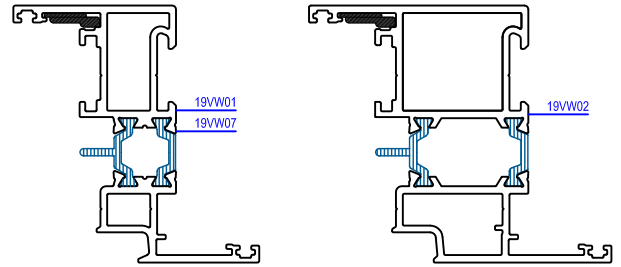



CODE	MO20	Plastic Corner Joint
------	------	----------------------

APPLICATION PROFILES	17VW01,17VW02,17VW03,17VW04,17VW05,17VW06 17VW07,17VW09
----------------------	--

MATERIALS	Black nylon
-----------	-------------

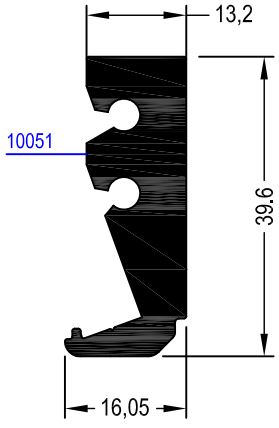
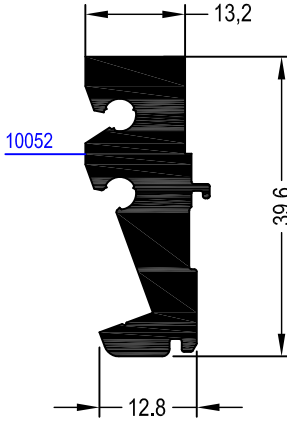
T JUNCTION

DRAWING / INFORMATION				APPLICATION			
 <p>10051</p>				 <p>10052</p>			
* pressed profile				* pressed profile			
T JUNCTION		13.2 / 39.6		T JUNCTION		13.2 / 39.6	
PROFILE CODE	14JW04	PRES	THEORETICAL WEIGHT kg/mt 1.056	PROFILE CODE	14JW05	PRES	THEORETICAL WEIGHT kg/mt 1.056
APPLICATION PROFILES	Cutting Sizes (mm)		PIECE CODE NUMBER 	APPLICATION PROFILES	Cutting Sizes (mm)		PIECE CODE NUMBER 
19MW01	10201	11.0 mm	-----	19MW01	10225	11.0 mm	-----
19MW02	10203	26.0 mm	-----	19MW02	10214	26.0 mm	-----
19MW03	10205	43.0 mm	-----	19MW03	10215	43.0 mm	-----
19MW07	10244	72.0 mm	-----	19MW07	10245	72.0 mm	-----
19MW15	10201	11.0 mm	-----	19MW15	X2	11.0 mm	-----
19MW16	X3	31.0 mm	-----	19MW16	X4	31.0 mm	-----
19MW08	10203	26.0 mm	-----	19MW16	10232	31.0 mm	-----
19MW10	10205	43.0 mm	-----	19MW10	10233	43.0 mm	-----
19MW12	10236	26.0 mm	-----	19MW12	10214	26.0 mm	-----
19MW13	10229	43.0 mm	-----	19MW13	10215	43.0 mm	-----
19AW14	XXXX	11.0 mm	-----	19AW14	10201	11.0 mm	-----

CORNER CLEATS

DRAWING / INFORMATION				APPLICATION			
* pressed profile				* pressed profile			
T JUNCTION		16.5 / 39.6		T JUNCTION		16.5 / 39.6	
PROFILE CODE	14JW06	PRES	THEORETICAL WEIGHT kg/mt 1.164	PROFILE CODE	14JW07	PRES	THEORETICAL WEIGHT kg/mt 1.170
APPLICATION PROFILES		Cutting Sizes (mm)	PIECE CODE NUMBER	APPLICATION PROFILES		Cutting Sizes (mm)	PIECE CODE NUMBER
17KW01	10263	37.2 mm	-----	17KW01	10264	37.2 mm	-----
17KW02	10265	69.2 mm	-----	17KW02	10266	69.2 mm	-----
17KW03	10267	95.2 mm	-----	17KW03	10268	95.2 mm	-----

HINGES

DRAWING / INFORMATION

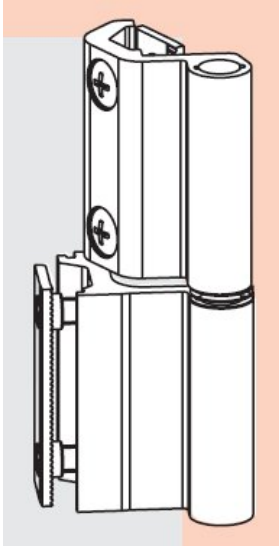

APPLICATION

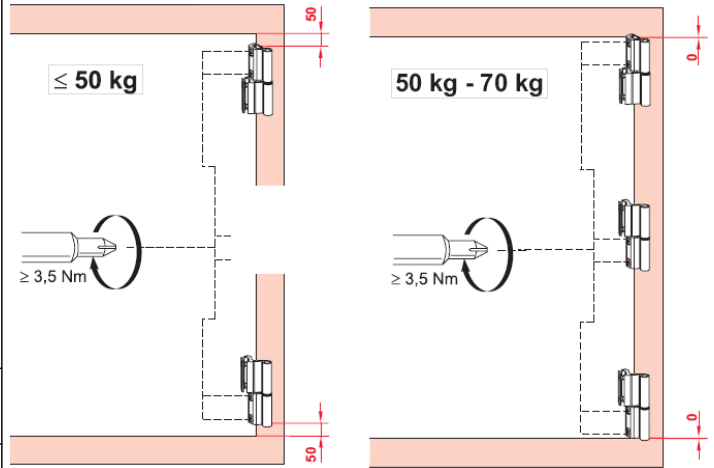

CODE 14A1701 Window Hinge

COLOURS White (RAL 9016) , Black (RAL 9005)
Anodized silver

MATERIALS Black nylon bush ,Hinges in extruded aluminium
Galvanized steel pin
Galvanized die cast zinc alloy

CAPACITIES 2 hinges : 50 kg
3 hinges : 70 kg

ROTO FRANK

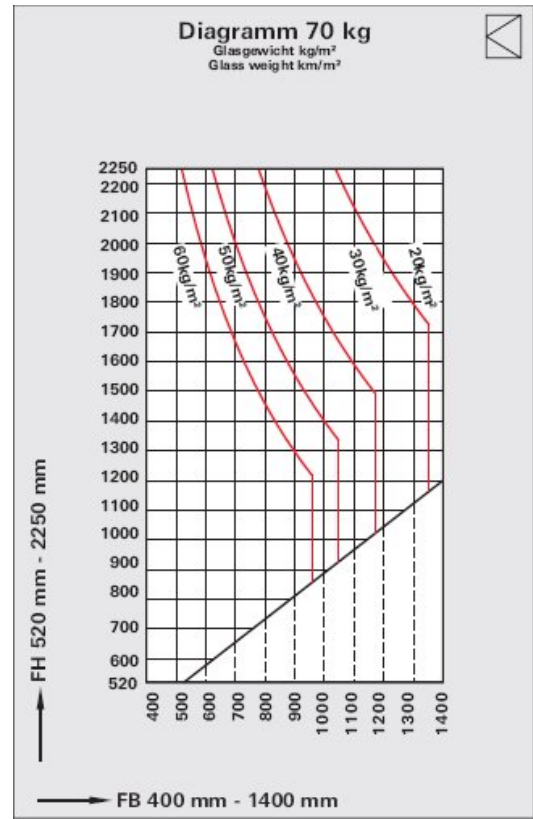
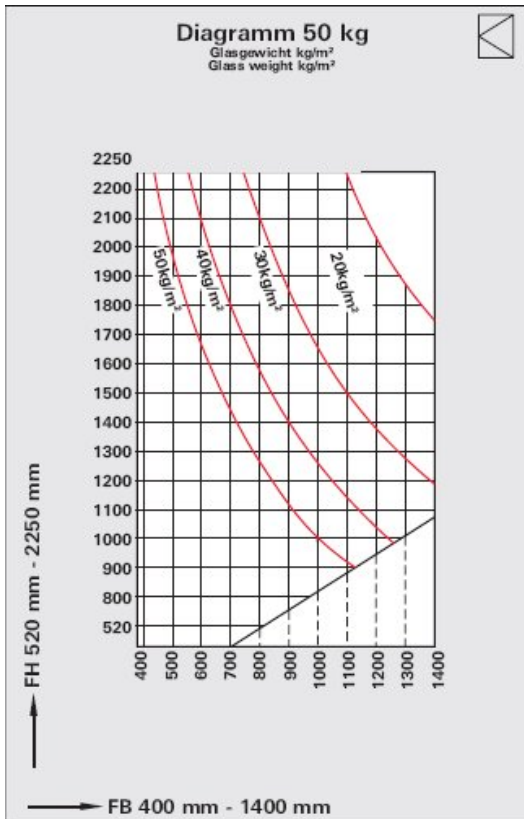

HINGES

DRAWING / INFORMATION

APPLICATION

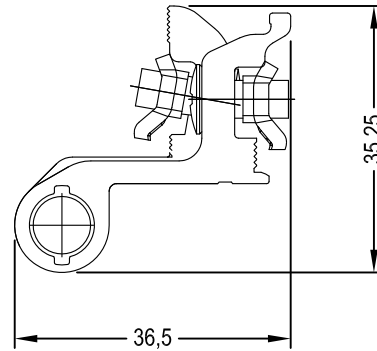
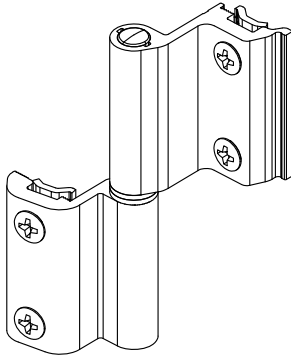

CODE 9730 Window Hinge

COLOURS White (RAL 9016) , Black (RAL 9005)

MATERIALS Hinges in extruded aluminium
Black nylon bush
Galvanized steel pin
Galvanized die cast zinc alloy

CAPACITIES 2 hinges : 80 kg
3 hinges : 90 kg

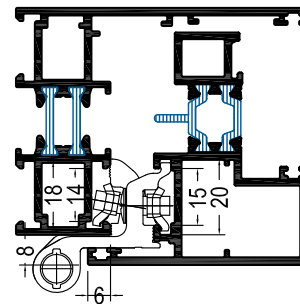
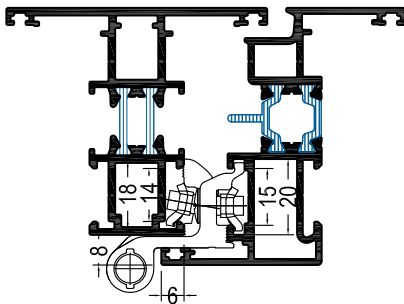
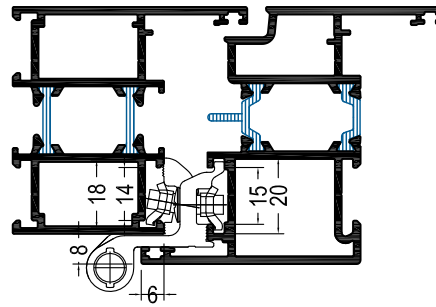
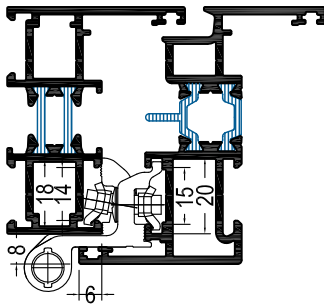

HINGES

DRAWING / INFORMATION

APPLICATION

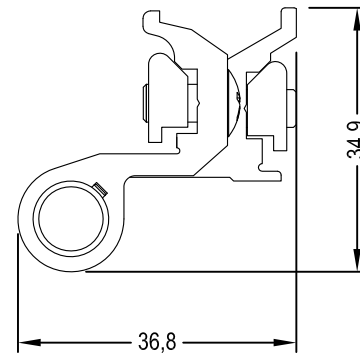
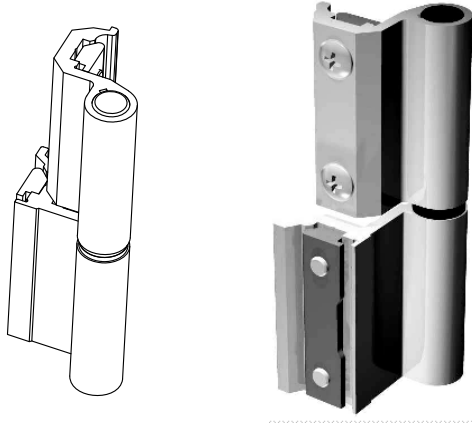

CODE M10 PR Window Hinge

COLOURS White (RAL 9016), Black (RAL 9005)
Electrostatic painted in RAL colours
Anodized silver and bronze

MATERIALS Hinges in extruded aluminium, 48 mm length
Black nylon bush
Galvanized steel pin
Galvanized die cast zinc alloy, 46.5 mm length

CAPACITIES 2 hinges : 80 kg
3 hinges : 90 kg

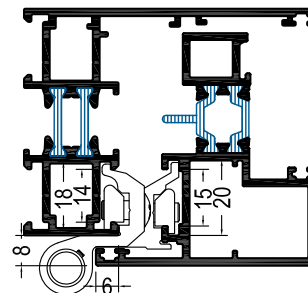
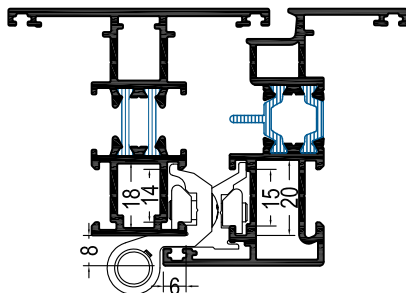
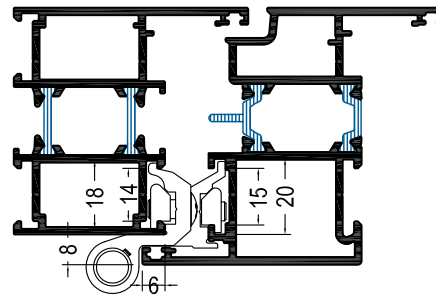
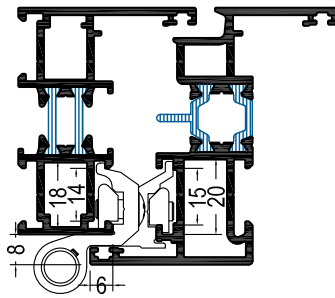

HINGES

DRAWING / INFORMATION

APPLICATION

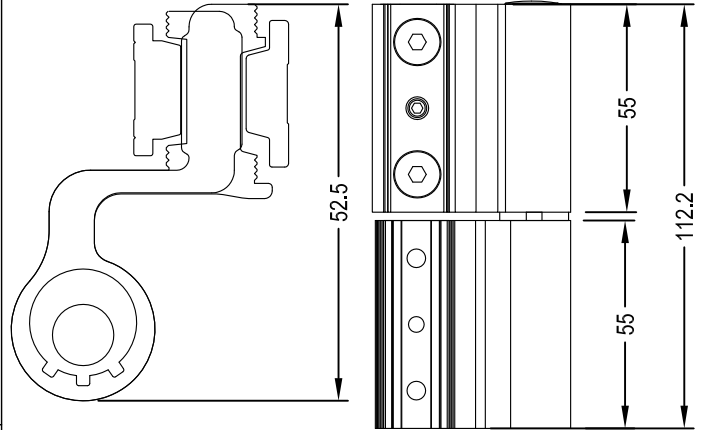

CODE 5603 Window Hinge

COLOURS	White (RAL 9016) , Black (RAL 9005)
MATERIALS	Hinges in extruded aluminium
	Black nylon bush
	Galvanized steel pin
	Galvanized die cast zinc alloy

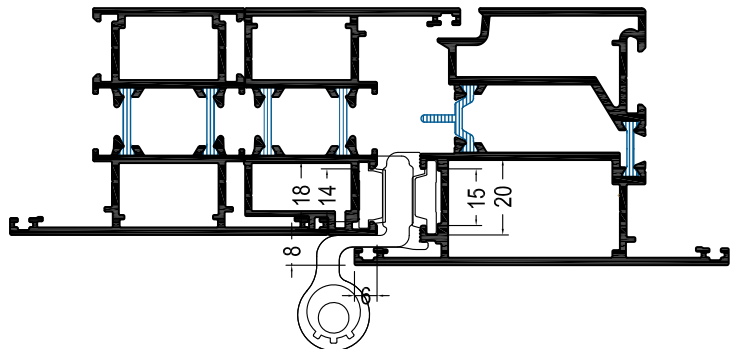
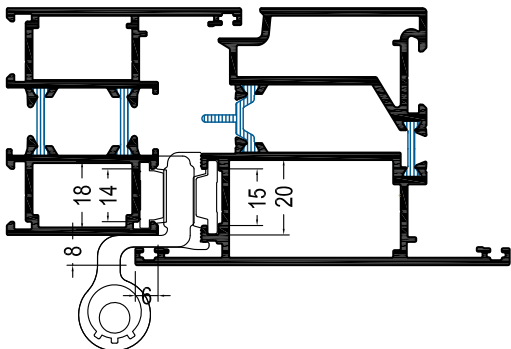
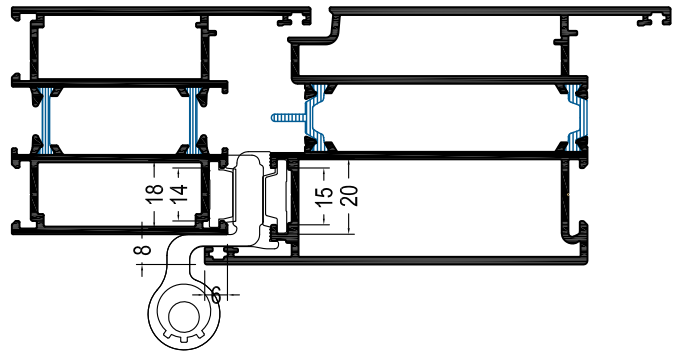
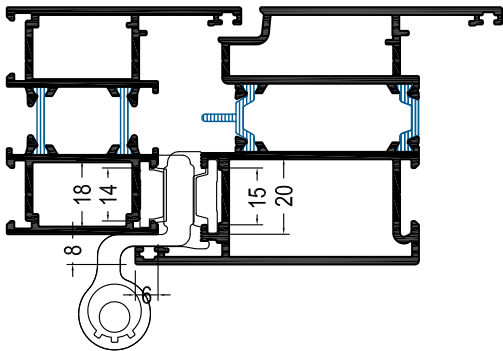

HINGES

DRAWING / INFORMATION

APPLICATION



VTF1560_01441

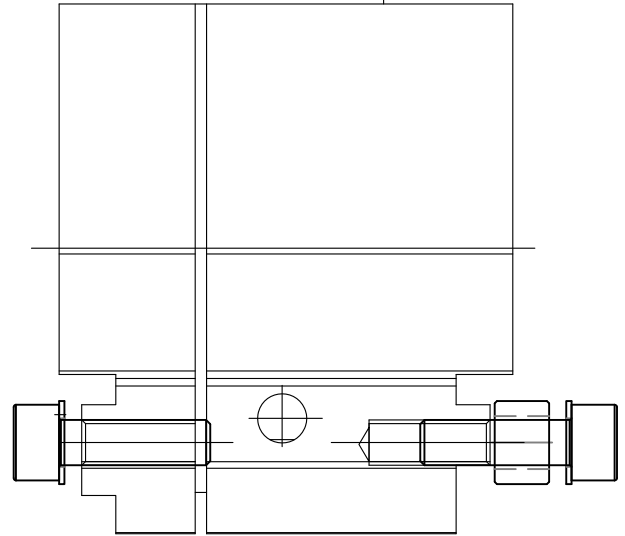

GIESSE VTF1560_01441

PIVOT Hinge

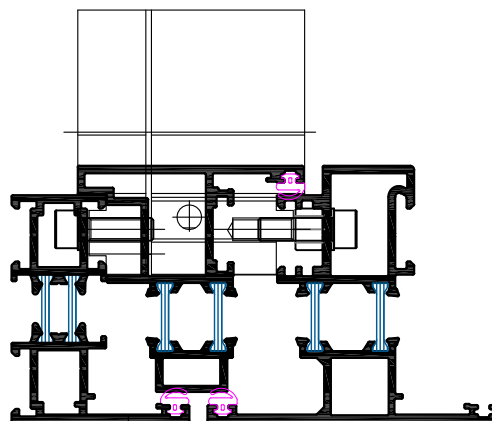

VASISTAS

DRAWING / INFORMATION

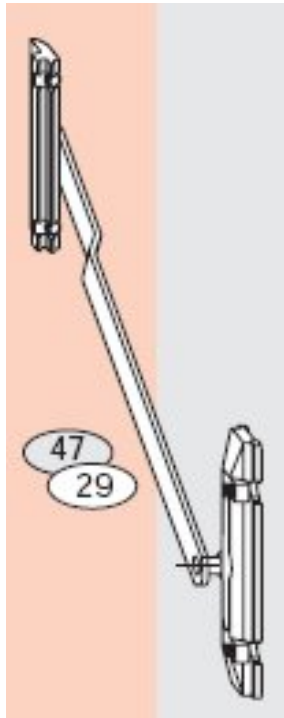

APPLICATION

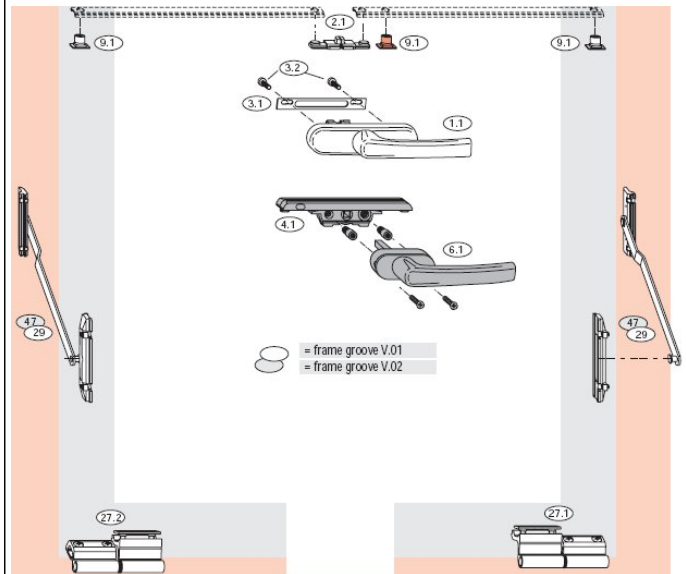

ROTO FRANK

CODE 14A1501 Vasistas



70kg

Limitation of sash formats

S.W. - Sash width 400mm - 1400mm
S.H. - Sash height 350mm - 1200mm
S.kg.max - Max. sash weight 70kg

The information in the application diagram refers to the glass weight in kg/m².

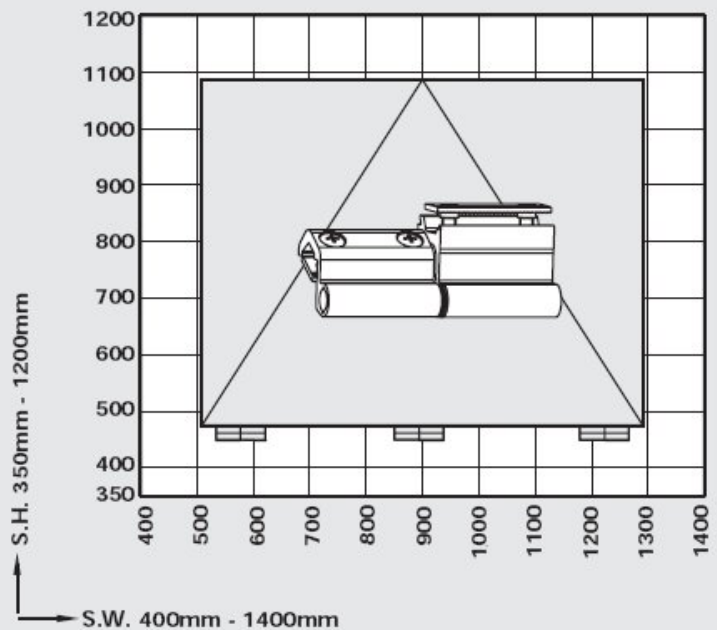

VASISTAS

DRAWING / INFORMATION

APPLICATION

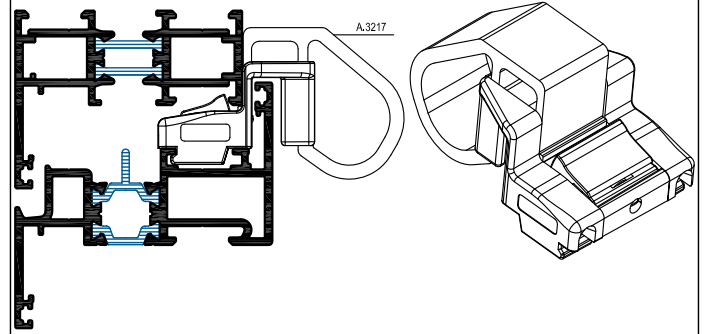
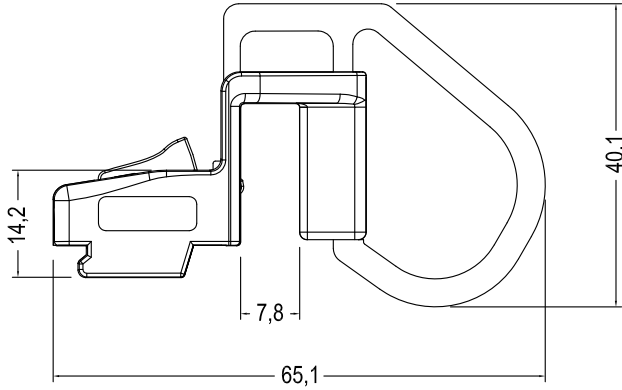

CODE A.3217 Vasistas Spring

COLOURS White (RAL 9016) , Black (RAL 9005)

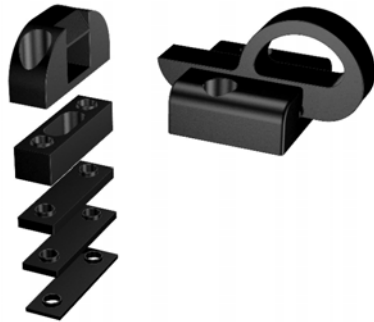

CODE 03209 Vasistas Spring

COLOURS Black

MATERIALS Black nylon

VASISTAS

DRAWING / INFORMATION

APPLICATION

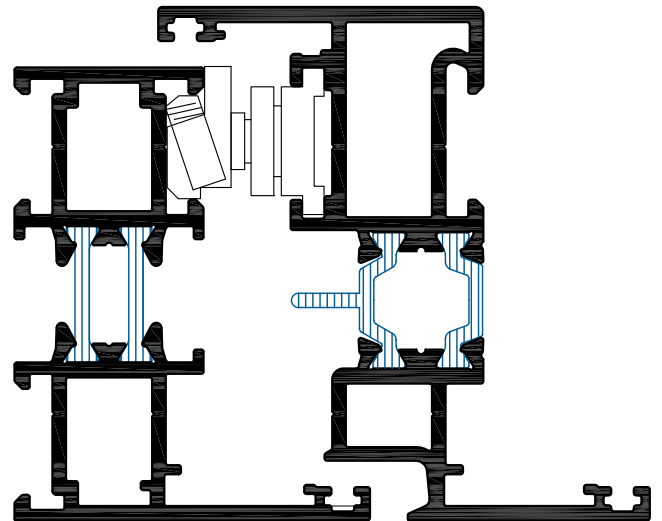
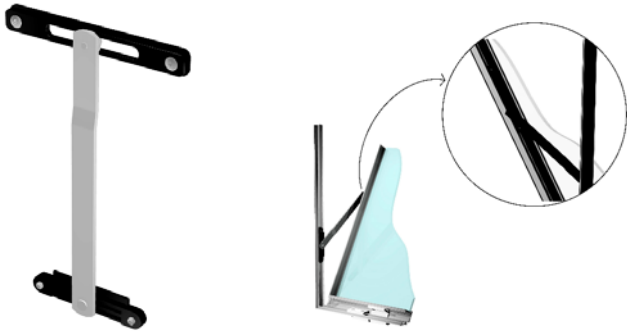

CODE 3207

Vasistas

COLOURS

Natural , Anodized silver and bronze
Electrostatic painted in RAL colours

MATERIALS

Extruded aluminium , 209 mm length
Black nylon bush
Galvanized steel pin

CAPACITIES

2 hinges : 60 kg
3 hinges : 70 kg

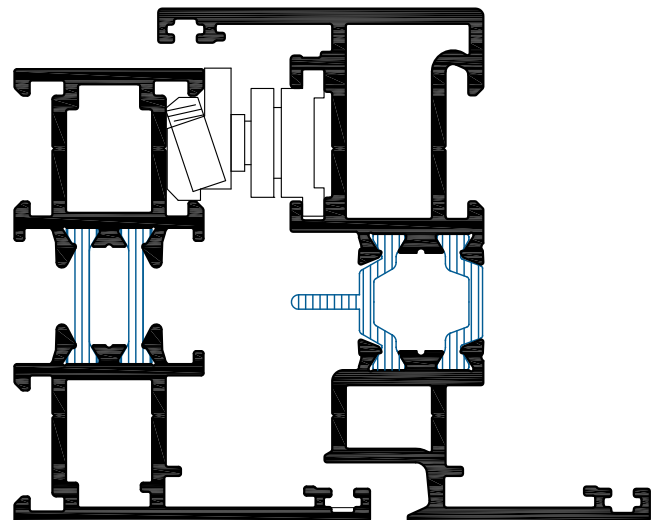

CODE ERT1861

Vasistas

COLOURS

Natural , Anodized silver and bronze
Electrostatic painted in RAL colours

LOCKING KIT

DRAWING / INFORMATION

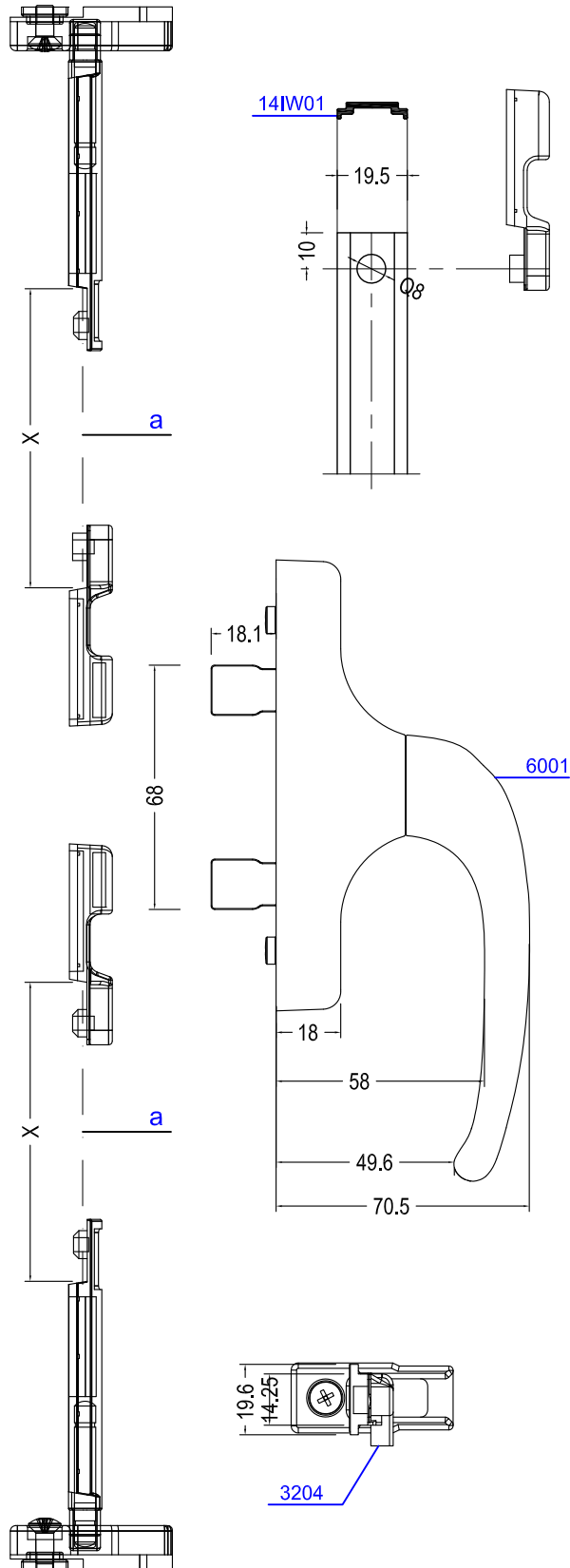

APPLICATION

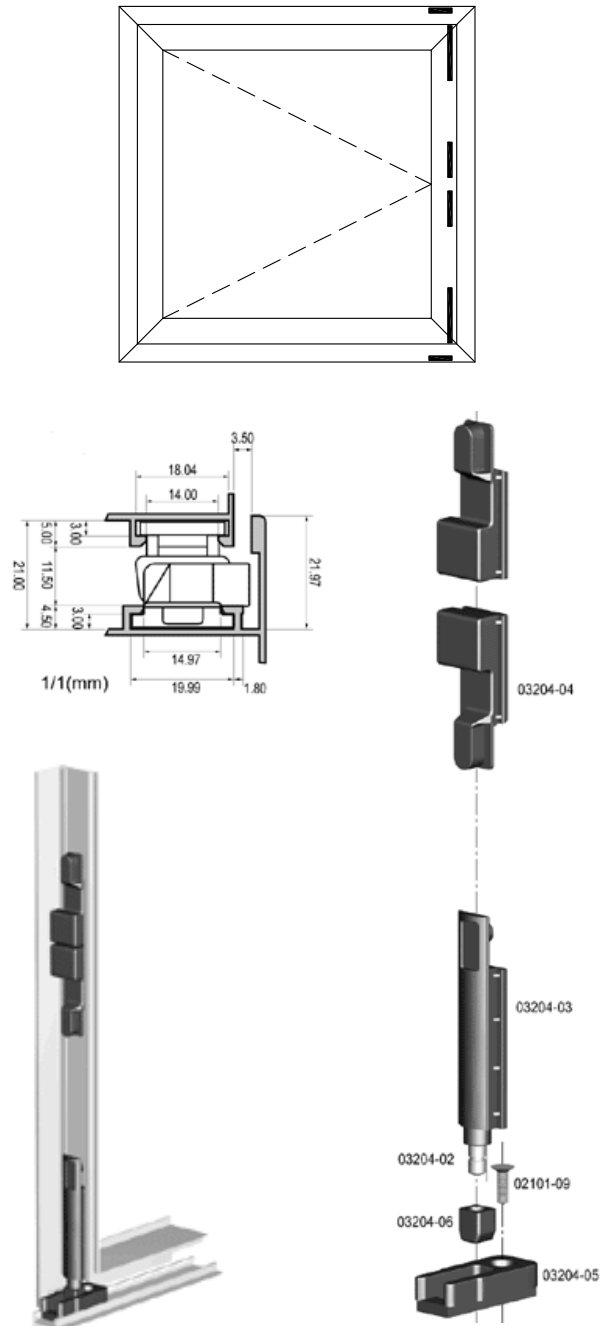

CODE	03204	Locking Kit
COLOURS	Black nylon and galvanized coated	
	Galvanized die-cast zinc alloy	
MATERIALS	Black nylon bush	
	Galvanized steel pin	

TURN WINDOWS MECHANISM

DRAWING

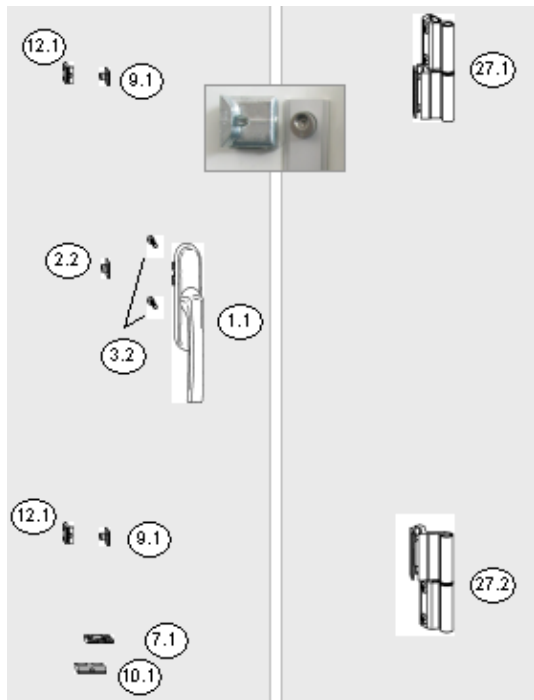

APPLICATION

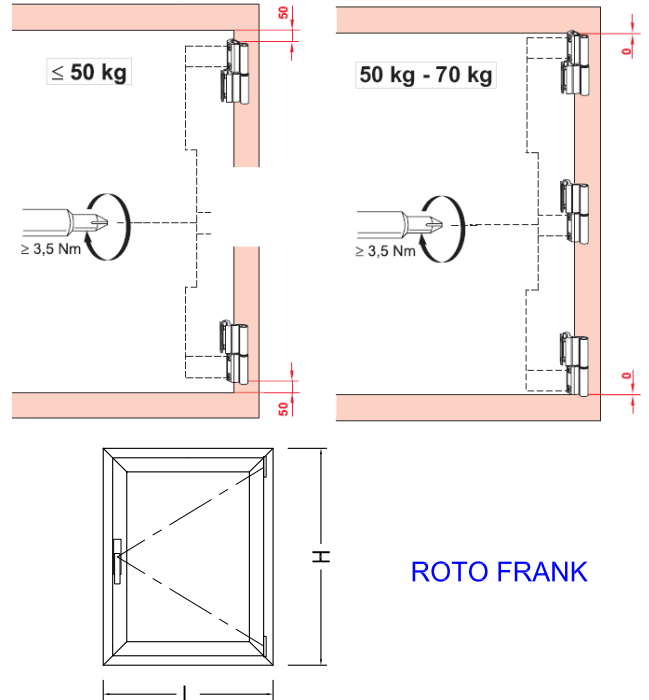

CODE	14A1701	Turn Windows Mechanism
Width L (mm)	Height H (mm)	Weight (kg)
400 mm - 1400 mm	520 mm - 2250 mm	50-70 Kg / m ²

CONTENTS	Hinges	2 set.
	Handle	1 set.
	Locking Group	1 set.

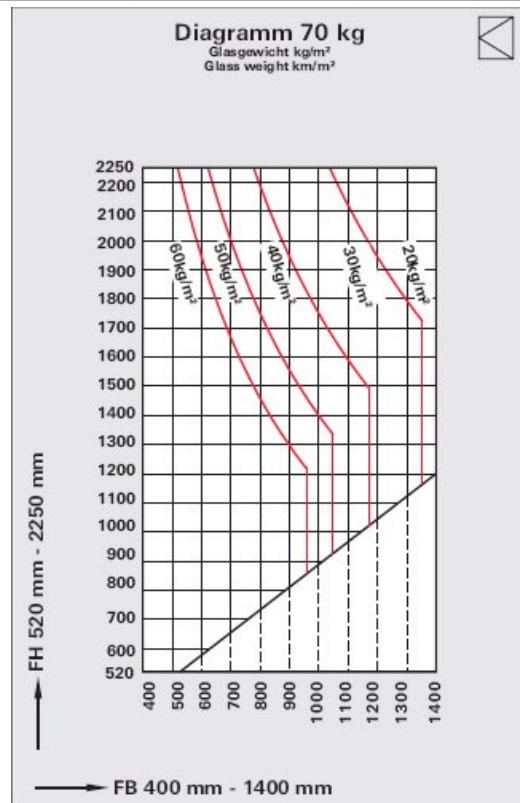
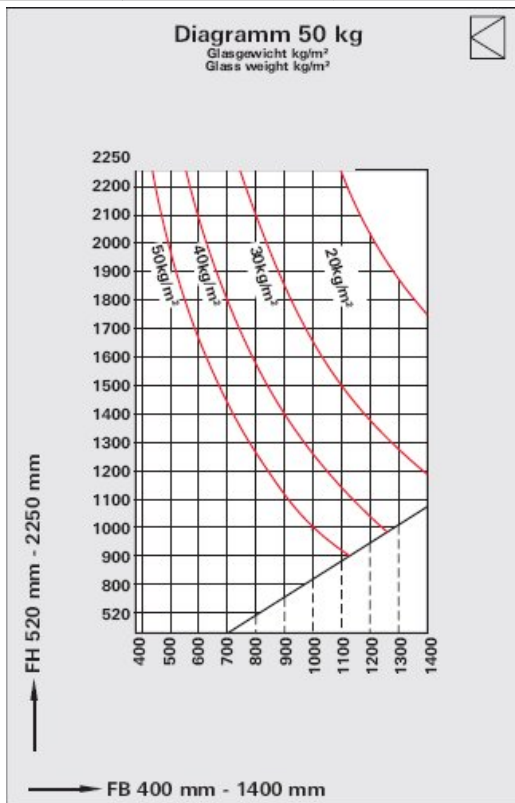

TURN AND TILT MECHANISM

DRAWING

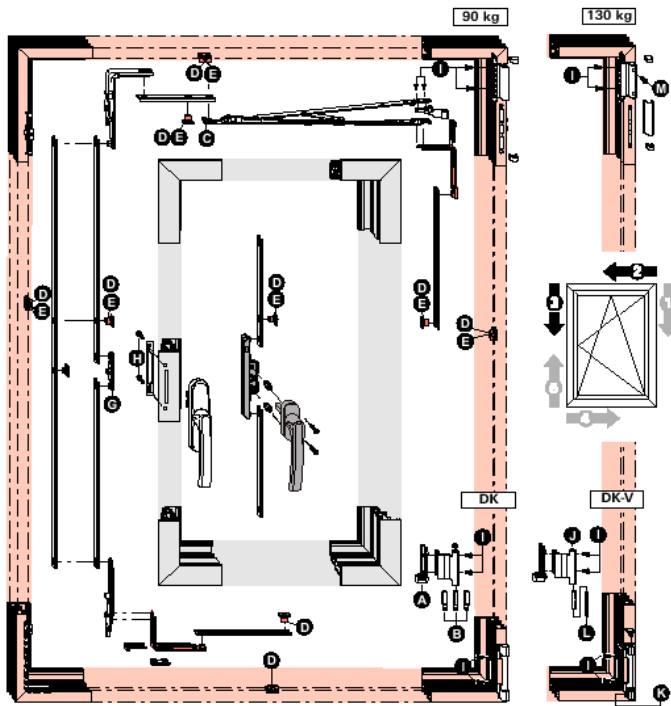

APPLICATION

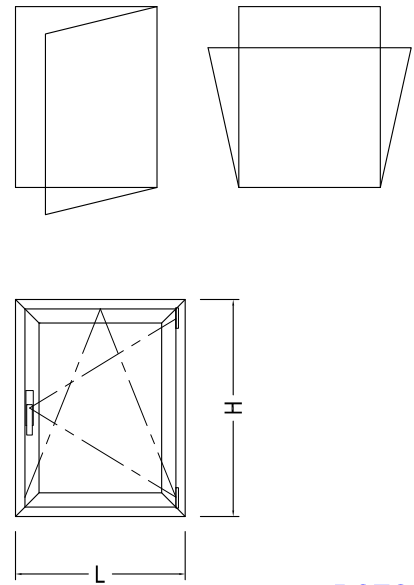

ROTO FRANK

CODE 14A1301 Turn and Tilt Mechanism

CODE 14A1302 Turn and Tilt Mechanism

Width L (mm)	Height H (mm)	Weight (kg)
405 mm - 1600 mm	520 mm - 2400 mm	90 Kg.

Width L (mm)	Height H (mm)	Weight (kg)
405 mm - 1600 mm	520 mm - 2400 mm	130 Kg.

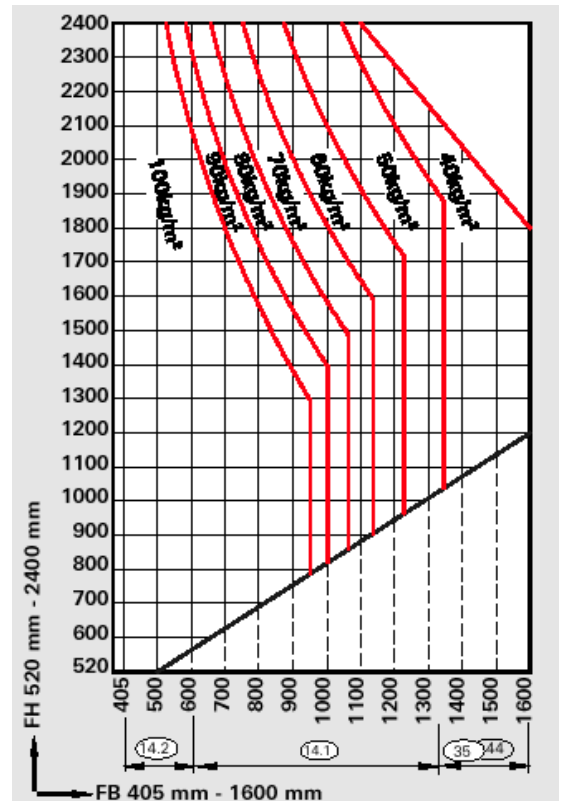
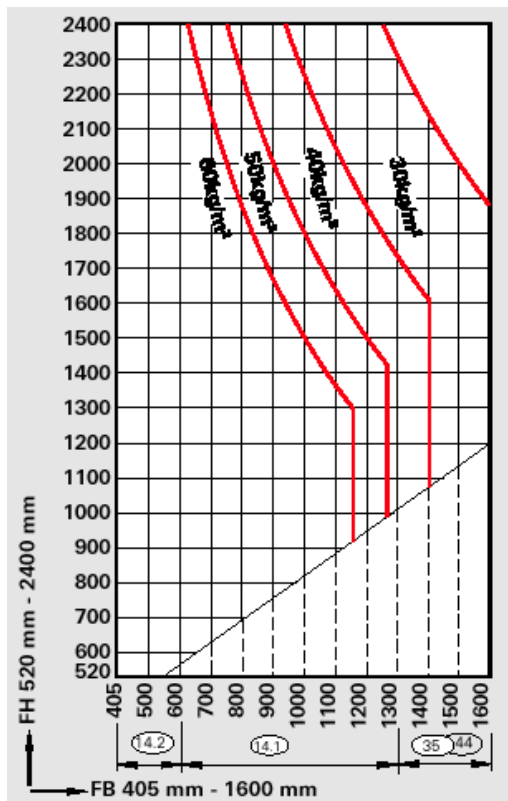

DRAWING / INFORMATION

APPLICATION

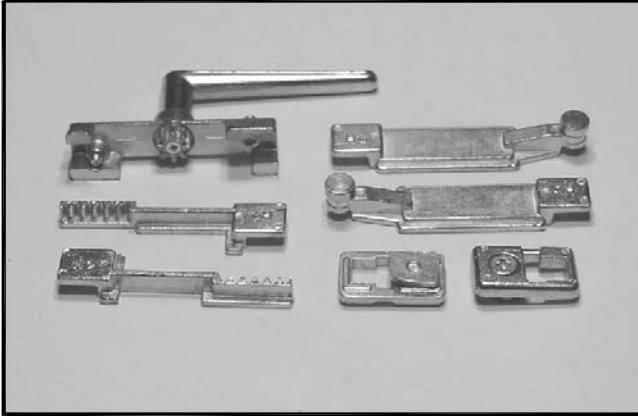

CODE MO 22.02 Window Bolt

CODE MO 22.01 Window Bolt

HANDLES

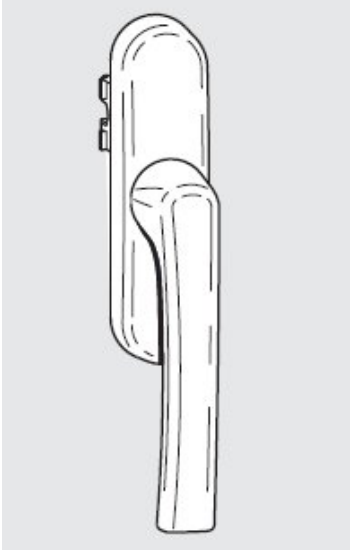
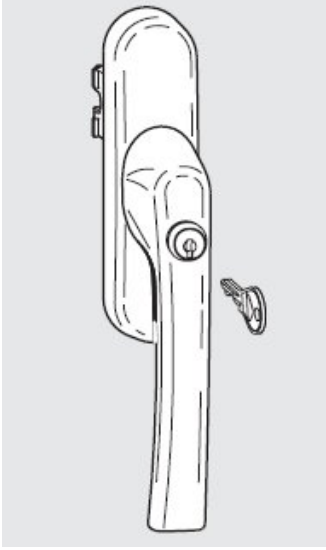
DRAWING / INFORMATION		APPLICATION	
 <p style="text-align: right;">ROTO FRANK</p>		 <p style="text-align: right;">ROTO FRANK</p>	
CODE	14A1101	Window Handle	
CODE	14A1102	Window Handle	
COLOURS	White (RAL 9016)	COLOURS	White (RAL 9016)
	Black (RAL 9005)		Black (RAL 9005)
	Anodized silver		Anodized silver
MATERIALS	Die-cast aluminium alloy	MATERIALS	Die-cast aluminium alloy
	Die-cast zinc alloy		Die-cast zinc alloy
	Black nylon		Black nylon

HANDLES

DRAWING / INFORMATION

APPLICATION

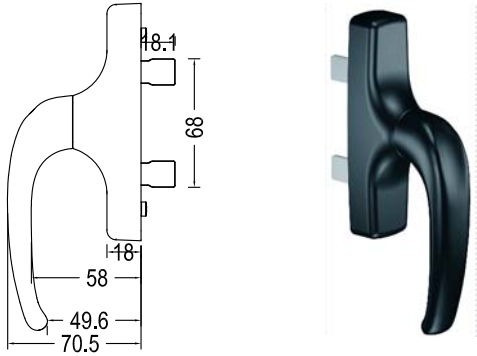

connection dimentions

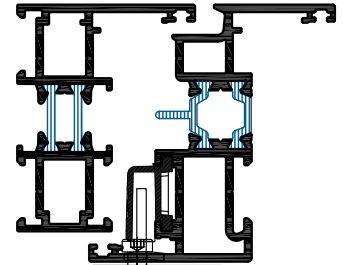
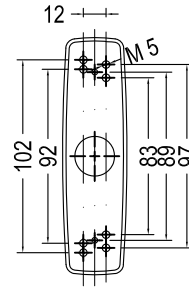

06001

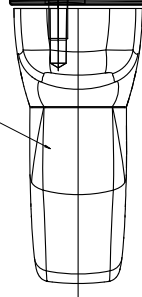

CODE 6001 Window Handle

COLOURS

- White (RAL 9016)
- Black (RAL 9005)
- Electrostatic painted in RAL colours

MATERIALS

- Die-cast aluminium alloy
- Die-cast zinc alloy
- Black nylon

connection dimentions

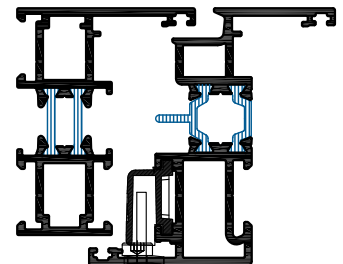
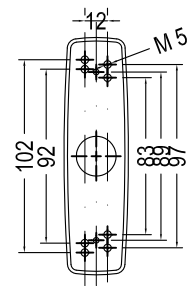

06002

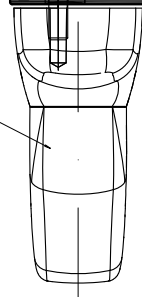

CODE 6002 Window Handle

COLOURS

- White (RAL 9016)
- Black (RAL 9005)
- Electrostatic painted in RAL colours

MATERIALS

- Die-cast aluminium alloy
- Die-cast zinc alloy
- Black nylon

HANDLES

DRAWING / INFORMATION

APPLICATION

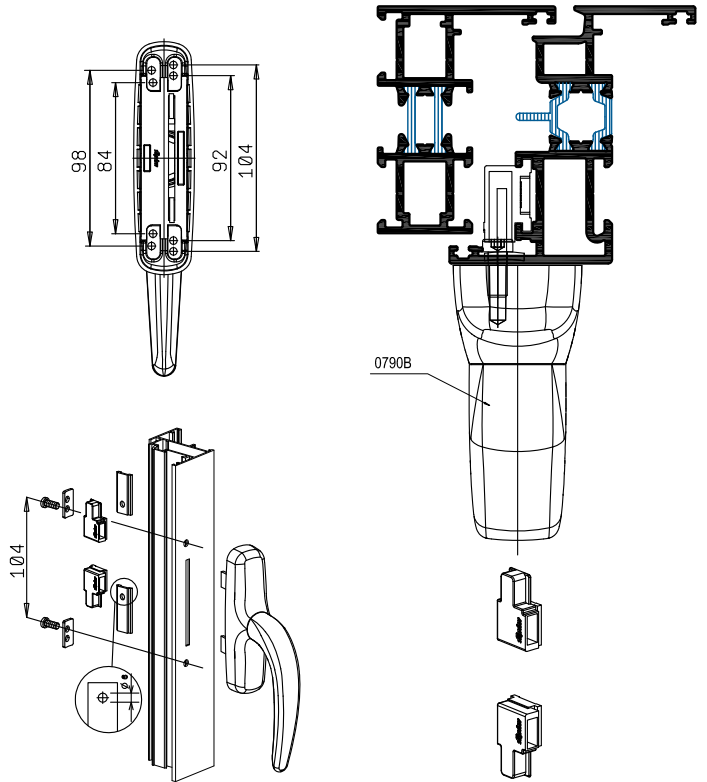
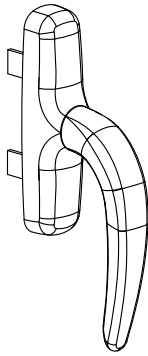

CODE	0790B	Window Handle
------	-------	---------------



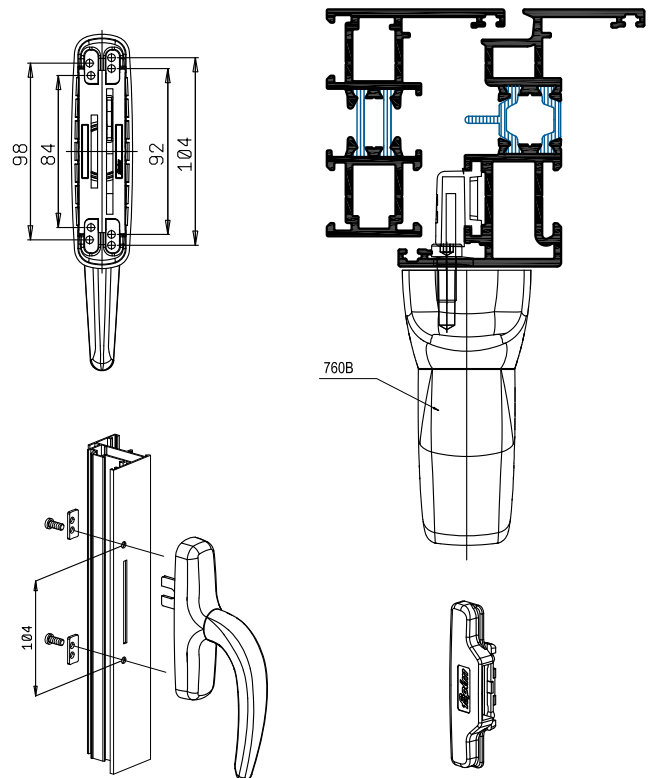
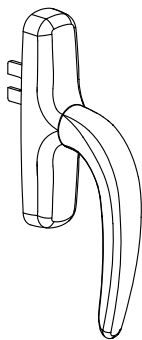

COLOURS	White (RAL 9016)
	Black (RAL 9005)
MATERIALS	Die-cast aluminium alloy
	Die-cast zinc alloy
	Black nylon



CODE	760B	Window Handle
------	------	---------------

COLOURS	White (RAL 9016)
	Black (RAL 9005)
MATERIALS	Die-cast aluminium alloy
	Die-cast zinc alloy
	Black nylon

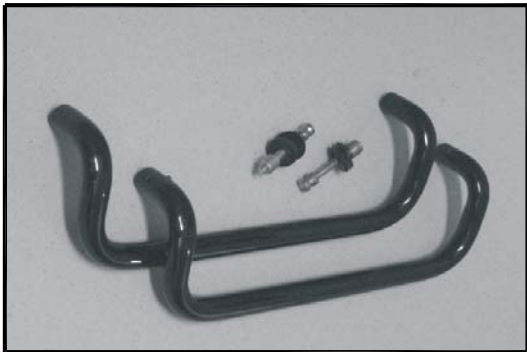
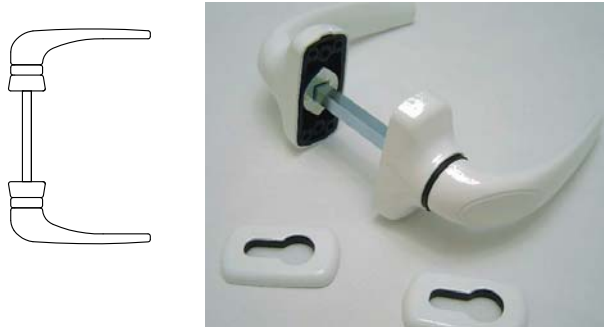
DOOR HANDLES

DRAWING / INFORMATION		APPLICATION	
			
CODE	X402	Door Handle	
CODE			AK23
CODE		Door Handle	Door Handle
COLOURS	White (RAL 9016) Black (RAL 9005)		White (RAL 9016) , Black (RAL 9005) Electrostatic painted in RAL colours , Anodized silver
			
CODE	X103	Door Handle	
CODE			AK20
CODE		Door Handle	Door Handle
COLOURS	White (RAL 9016) Black (RAL 9005)		White (RAL 9016) , Black (RAL 9005) Electrostatic painted in RAL colours , Anodized silver
			
CODE	DH605	Door Handle	
CODE			AK21
CODE		Door Handle	Door Handle
COLOURS	White (RAL 9016) Black (RAL 9005)		White (RAL 9016) , Black (RAL 9005) Electrostatic painted in RAL colours , Anodized silver

COVERS

DRAWING / INFORMATION

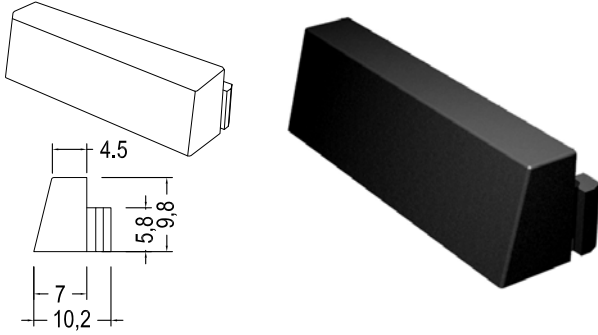

CODE 08000-03 Drainage Cover

COLOURS Black , White

MATERIALS Black nylon

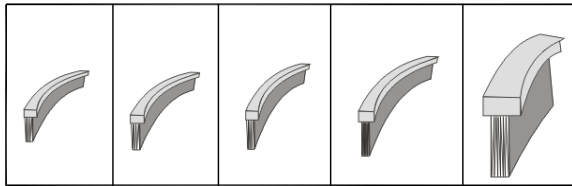

PB - 6 PB - 7 PB - 8 PB - 10 PB - 13

CODE Brush

COLOURS Grey

MATERIALS Black nylon

APPLICATION

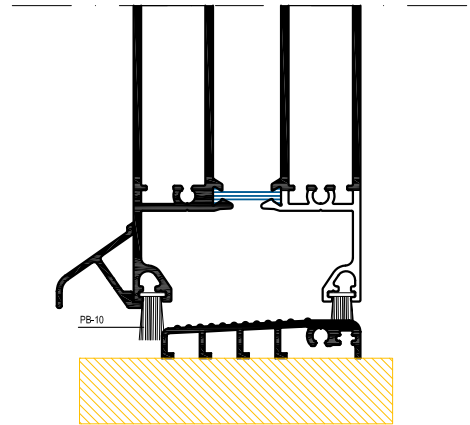
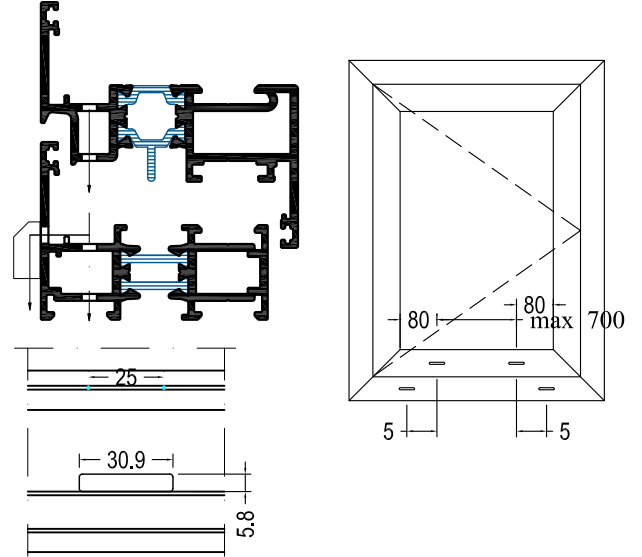

MORTISE LOCKS

DRAWING / INFORMATION

APPLICATION

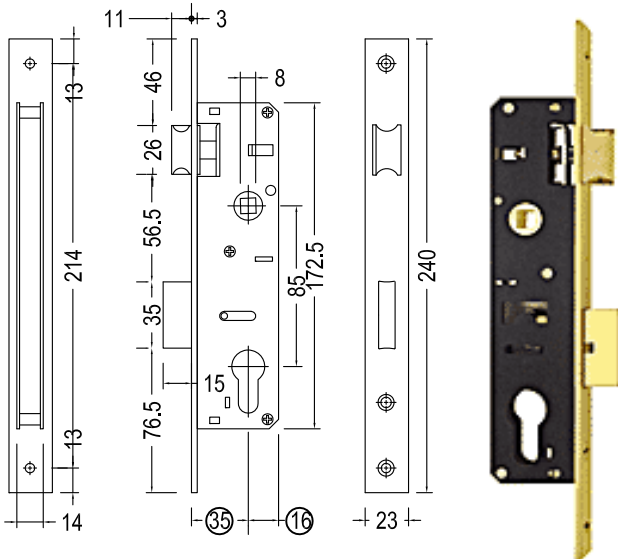

TYPE	B
153 35	35

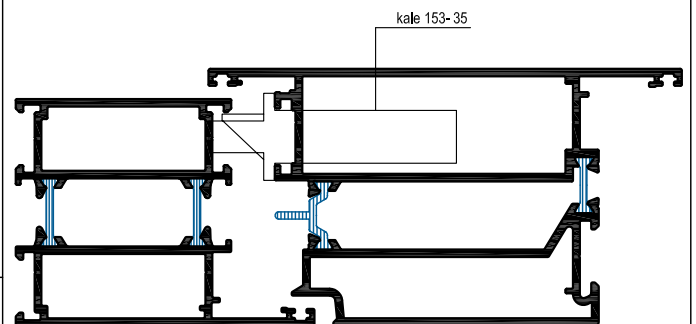
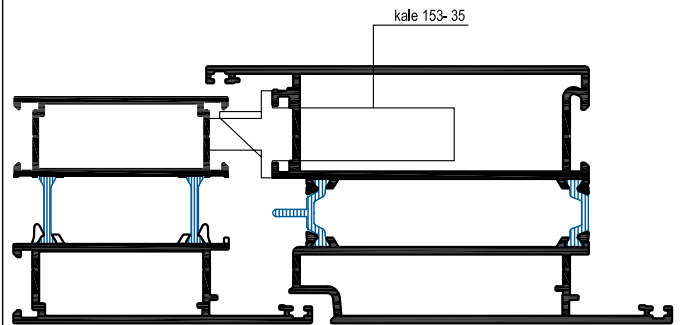
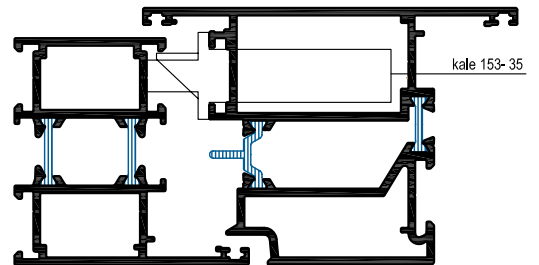
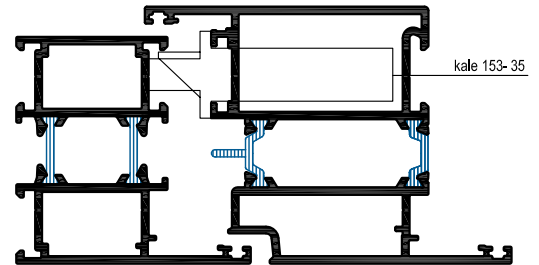

CODE	153 35	Mortise Lock
CYLINDER	DOMUS 16090K (90)	
UNIT WEIGHT	830 gr	
MATERIALS	Case : Steel , Electrostatic black powder painted	
	Deadbolt : Zinc alloy	
	Latch : MS 58 Brass	

MORTISE LOCKS

DRAWING / INFORMATION

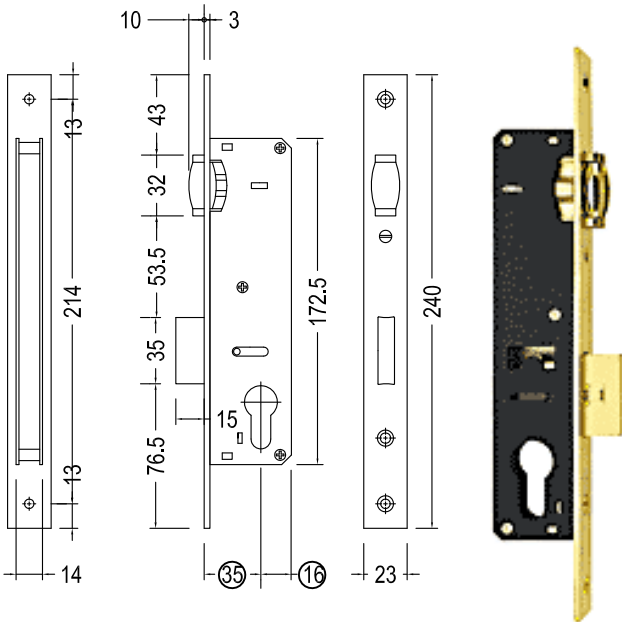

TYPE	B
155 35	35

APPLICATION

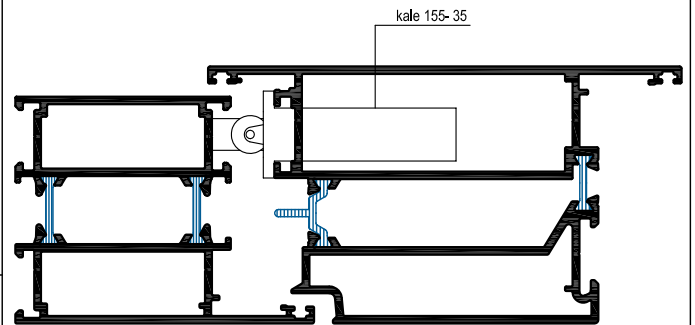
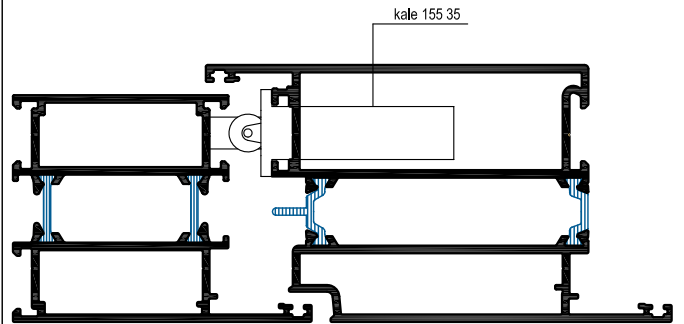
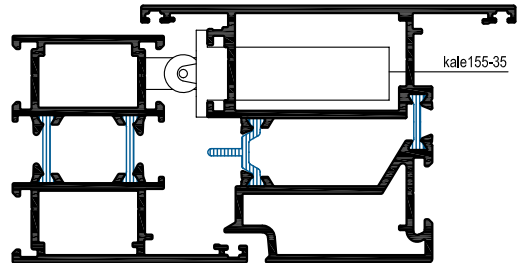
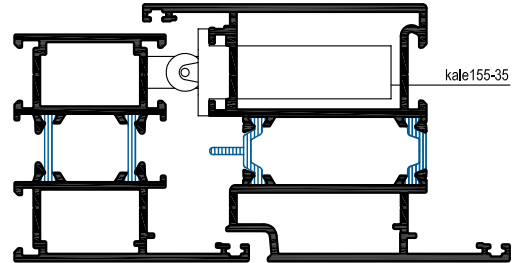

CODE 155 35 Mortise Lock

CYLINDER	DOMUS 16090K (90)
UNIT WEIGHT	830 gr
MATERIALS	Case : Steel , Electrostatic black powder painted
	Deadbolt : Zinc alloy
	Latch : MS 58 Brass

MORTISE LOCKS

DRAWING / INFORMATION

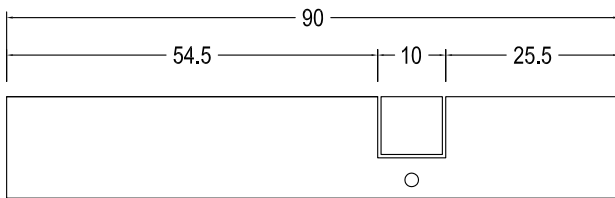

APPLICATION

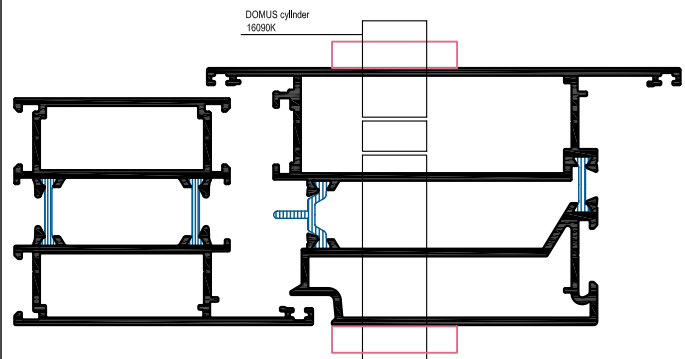
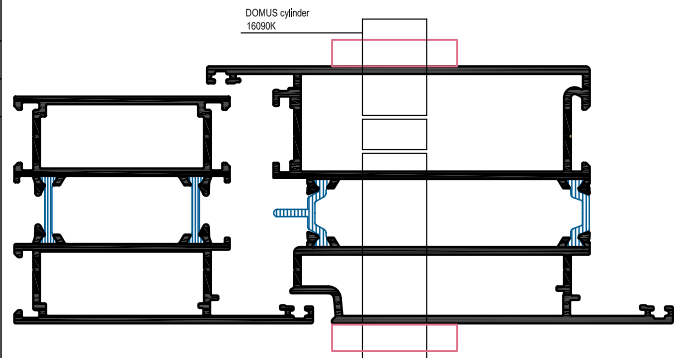
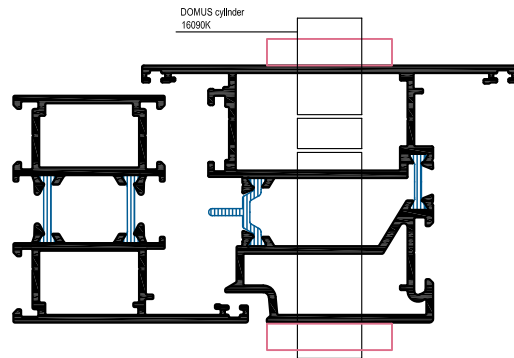
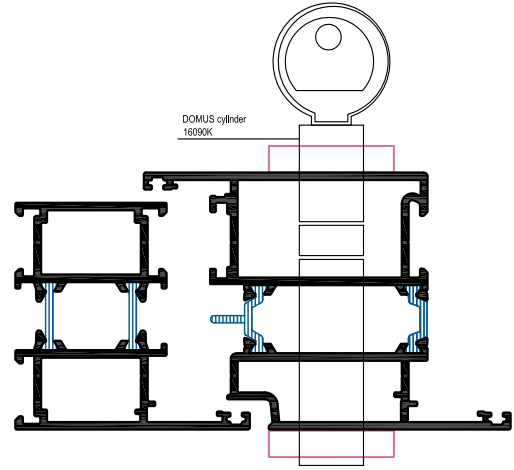

CODE DOMUS 16090K Cylinder

MATERIALS

Lenght 90 mm
Nickel

MORTISE LOCKS

DRAWING / INFORMATION

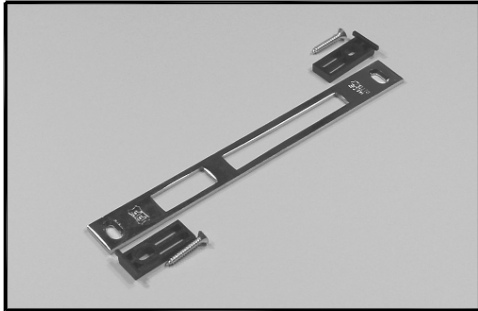

CODE

AA 03205

Striking Plate

MATERIALS

Chomized steel , 206.5 mm lenght
Black nylon bush

APPLICATION

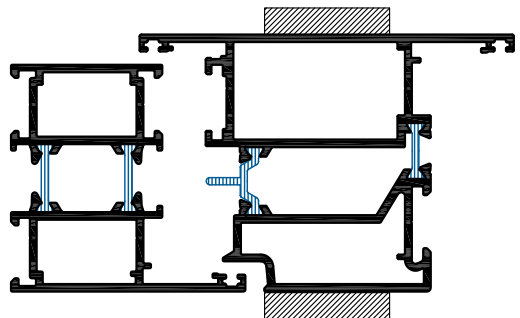
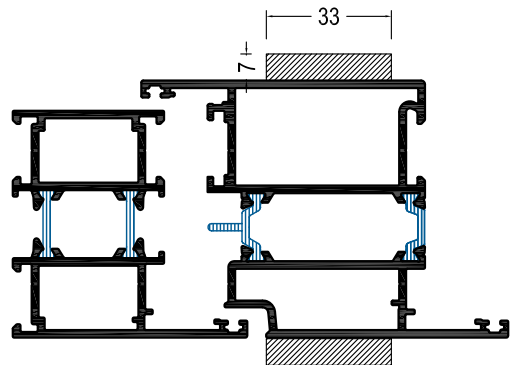
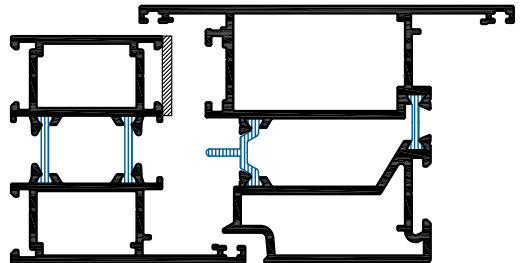
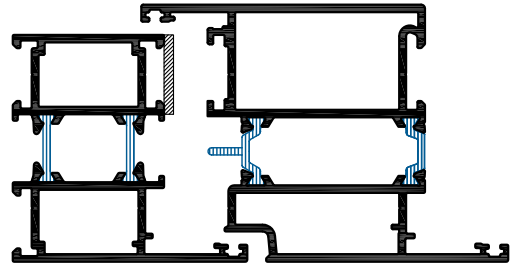

CODE

DRAWING / INFORMATION

APPLICATION

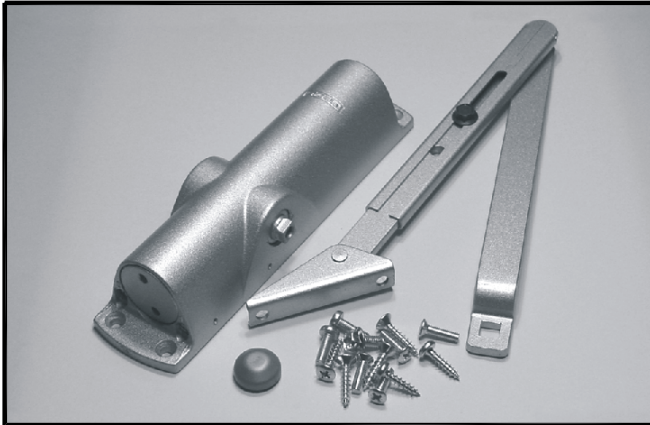

CODE GEZE TS 1000

CODE 2215

Bolt

d - TABLE

A	B	C	D	E	F
GLAZING BEAD	GLAZING THICKNESS	GLAZING GASKET INSIDE	GLAZING GASKET OUTSIDE	WEDGES	WEDGES
14GW12	5 mm	11A1103	11A2701	17A1801	17A1802
14GW12	6 mm	11A1102	11A2701	17A1801	17A1802
14GW11	8 mm	11A1103	11A2701	17A1801	17A1802

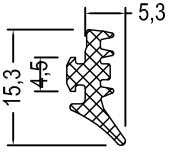
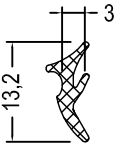
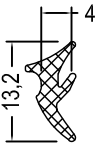
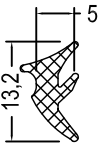
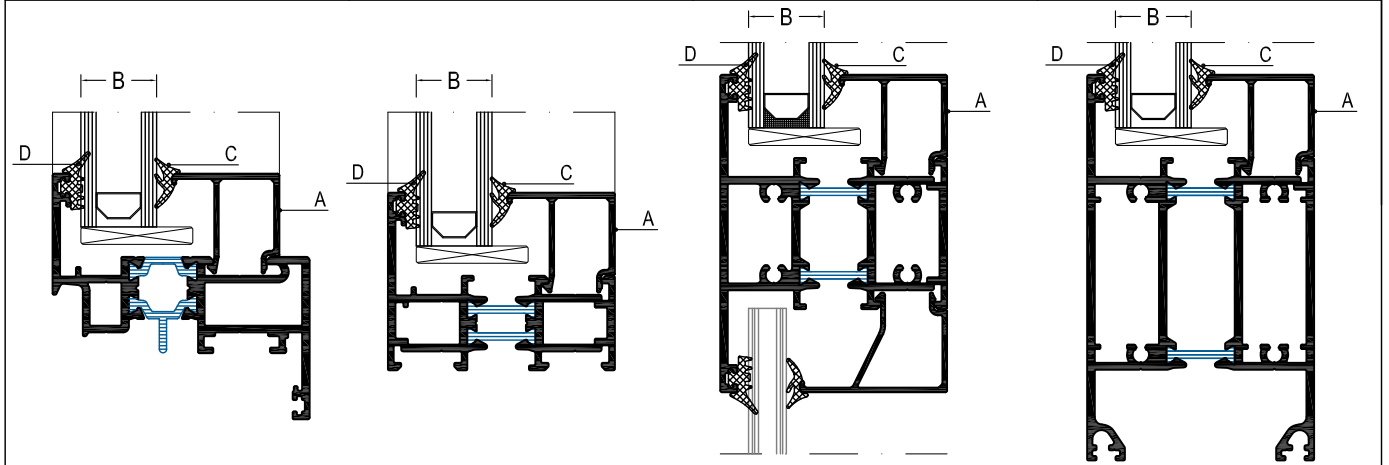
			
<p>3 mm - 11A2701</p>	<p>3 mm - 11A1101</p>	<p>4 mm - 11A1102</p>	<p>5 mm - 11A1103</p>
			
<p>A GLAZING BEAD</p>	<p>B GLAZING THICKNESS</p>	<p>C GLAZING GASKET INSIDE</p>	<p>D GLAZING GASKET OUTSIDE</p>
<p>14GW10</p>	<p>17 mm</p>	<p>11A1103</p>	<p>11A2701</p>
<p>14GW10</p>	<p>18 mm</p>	<p>11A1102</p>	<p>11A2701</p>
<p>14GW09</p>	<p>20 mm</p>	<p>11A1103</p>	<p>11A2701</p>
<p>14GW09</p>	<p>22 mm</p>	<p>11A1101</p>	<p>11A2701</p>
<p>14GW19</p>	<p>24 mm</p>	<p>11A1103</p>	<p>11A2701</p>
<p>14GW07</p>	<p>26 mm</p>	<p>11A1103</p>	<p>11A2701</p>
<p>14GW07</p>	<p>28 mm</p>	<p>11A1101</p>	<p>11A2701</p>
<p>14GW06</p>	<p>30 mm</p>	<p>11A1102</p>	<p>11A2701</p>
<p>14GW05</p>	<p>32 mm</p>	<p>11A1103</p>	<p>11A2701</p>
<p>14GW05</p>	<p>34 mm</p>	<p>11A1101</p>	<p>11A2701</p>
<p>14GW04</p>	<p>36 mm</p>	<p>11A1102</p>	<p>11A2701</p>
<p>14GW03</p>	<p>38 mm</p>	<p>11A1103</p>	<p>11A2701</p>
<p>14GW03</p>	<p>40 mm</p>	<p>11A1101</p>	<p>11A2701</p>

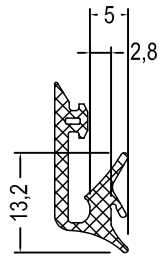

4 mm - 11A1104

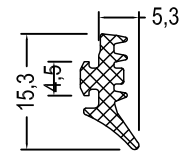

3 mm - 11A2701

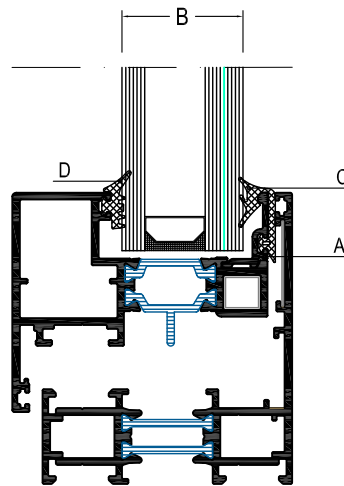

A GLAZING BEAD	B GLAZING THICKNESS	C GLAZING GASKET INSIDE	D GLAZING GASKET OUTSIDE
14GW20	26 mm	11A1104	11A2701

e - DETAILS

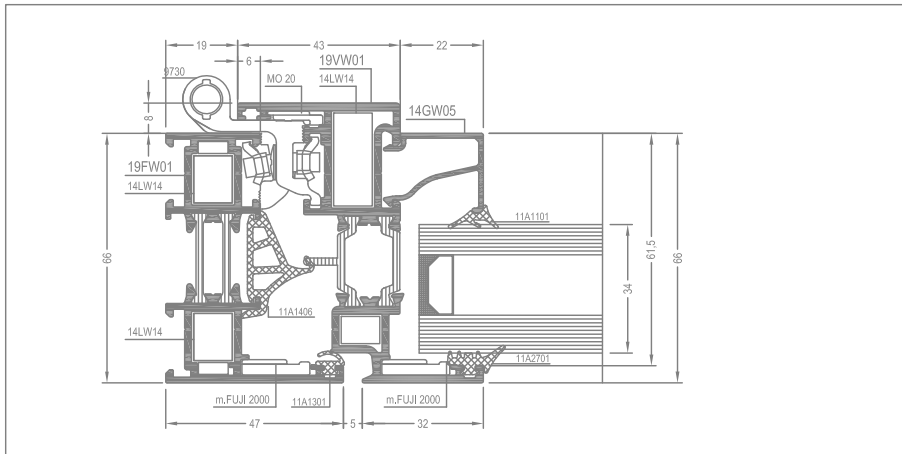

TURNING WINDOW

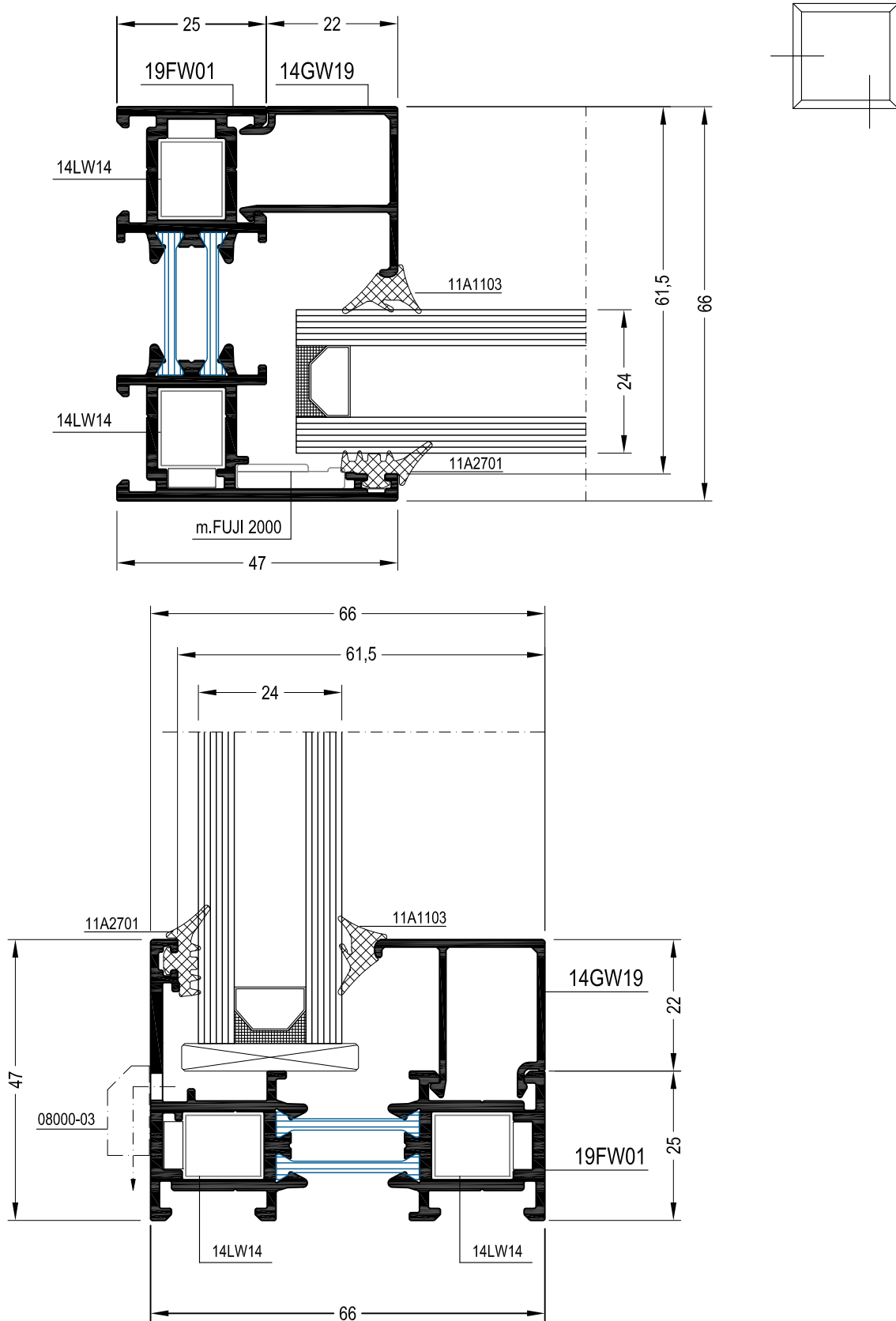

TURNING WINDOW

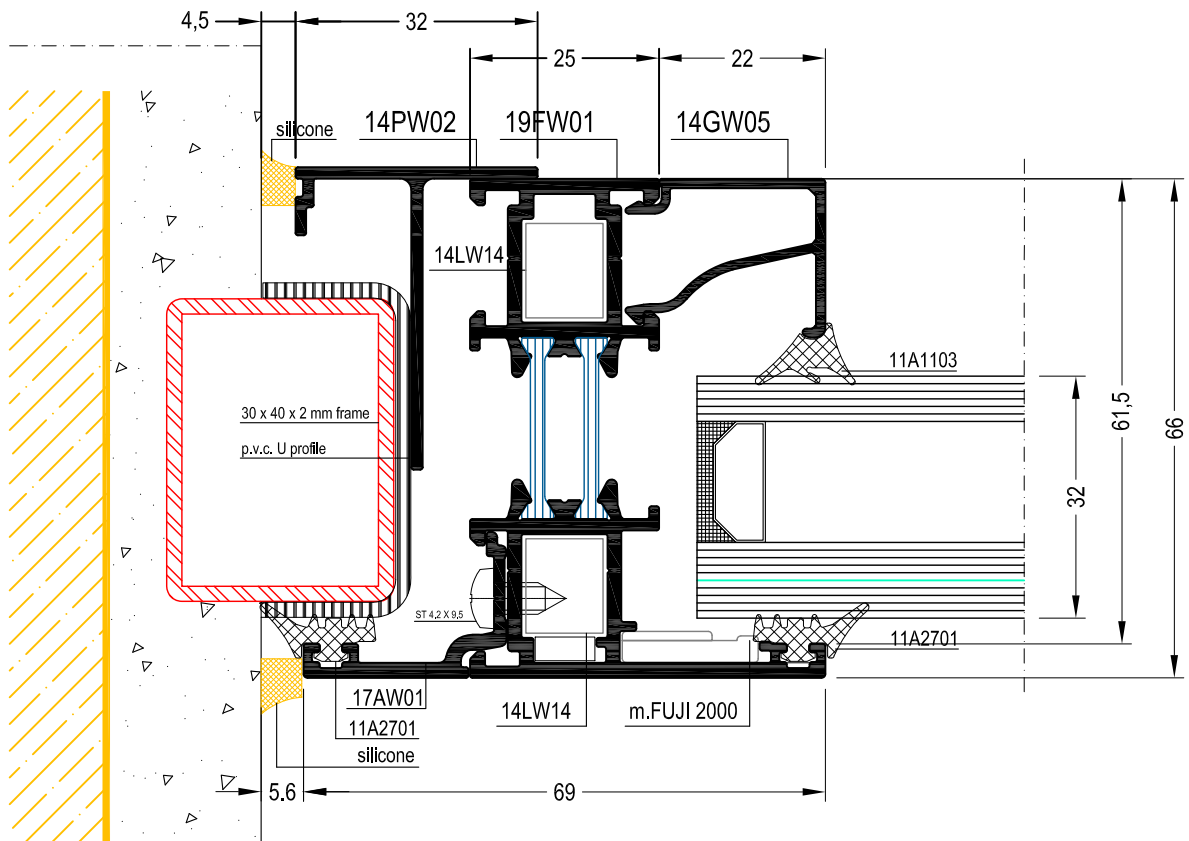
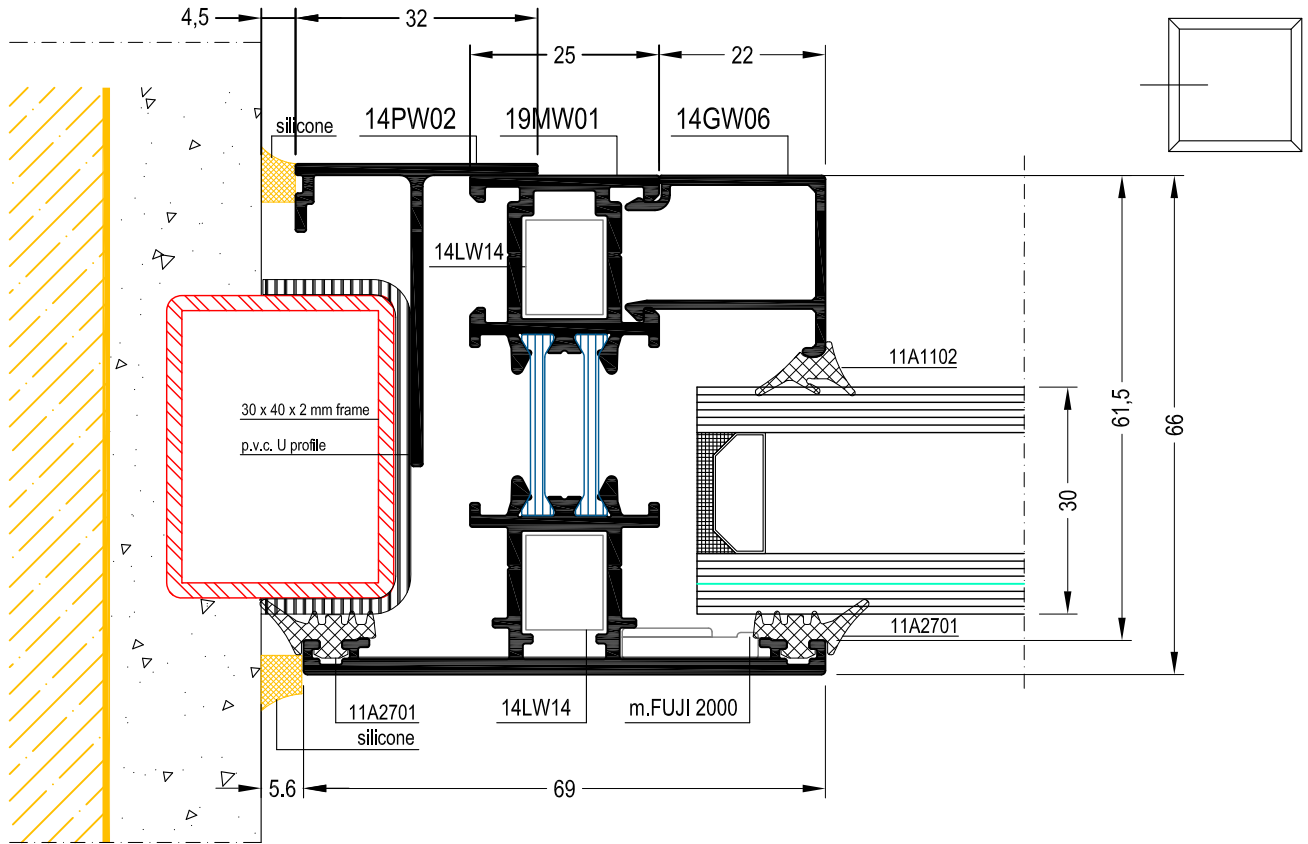

TURNING WINDOW

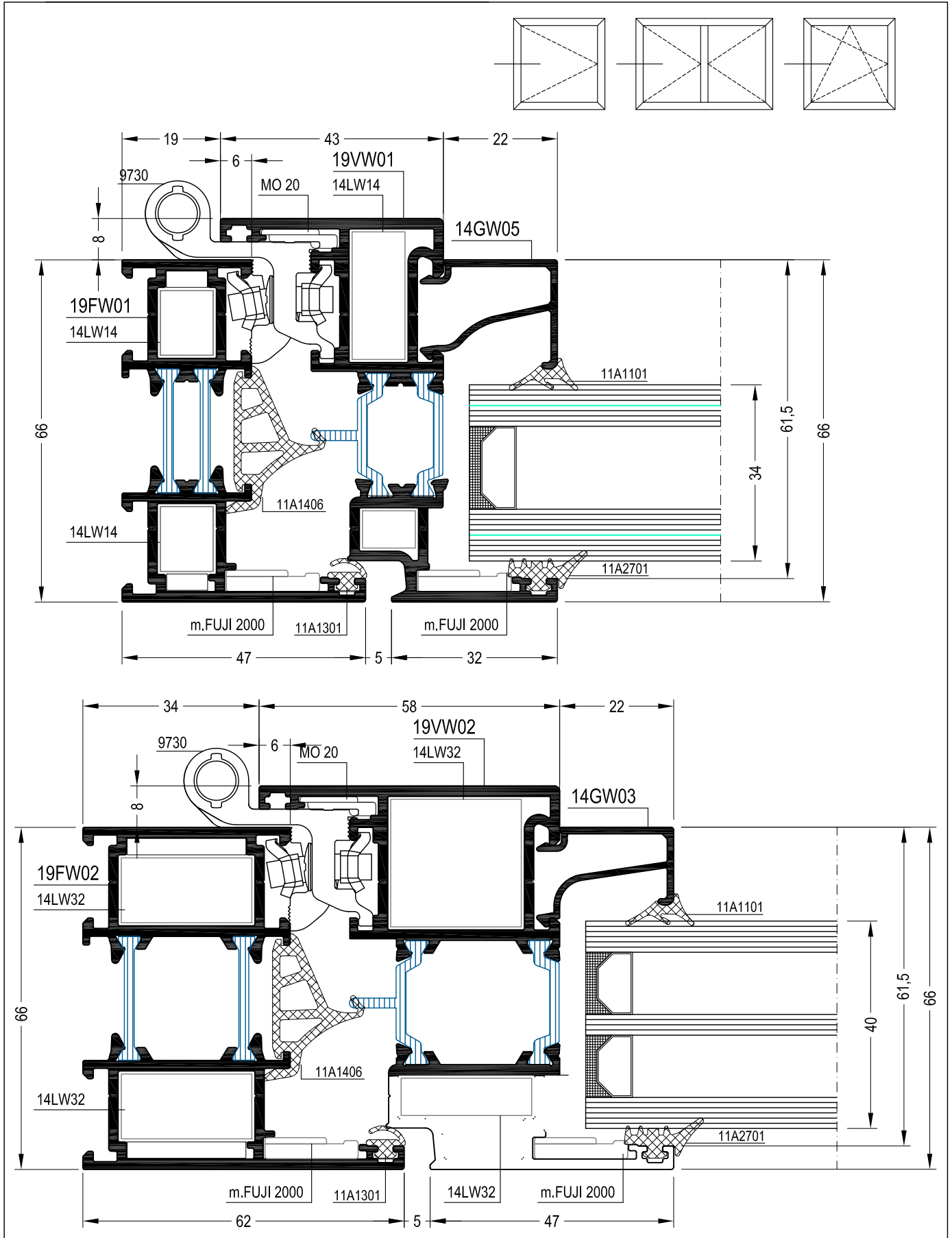

TURNING WINDOW

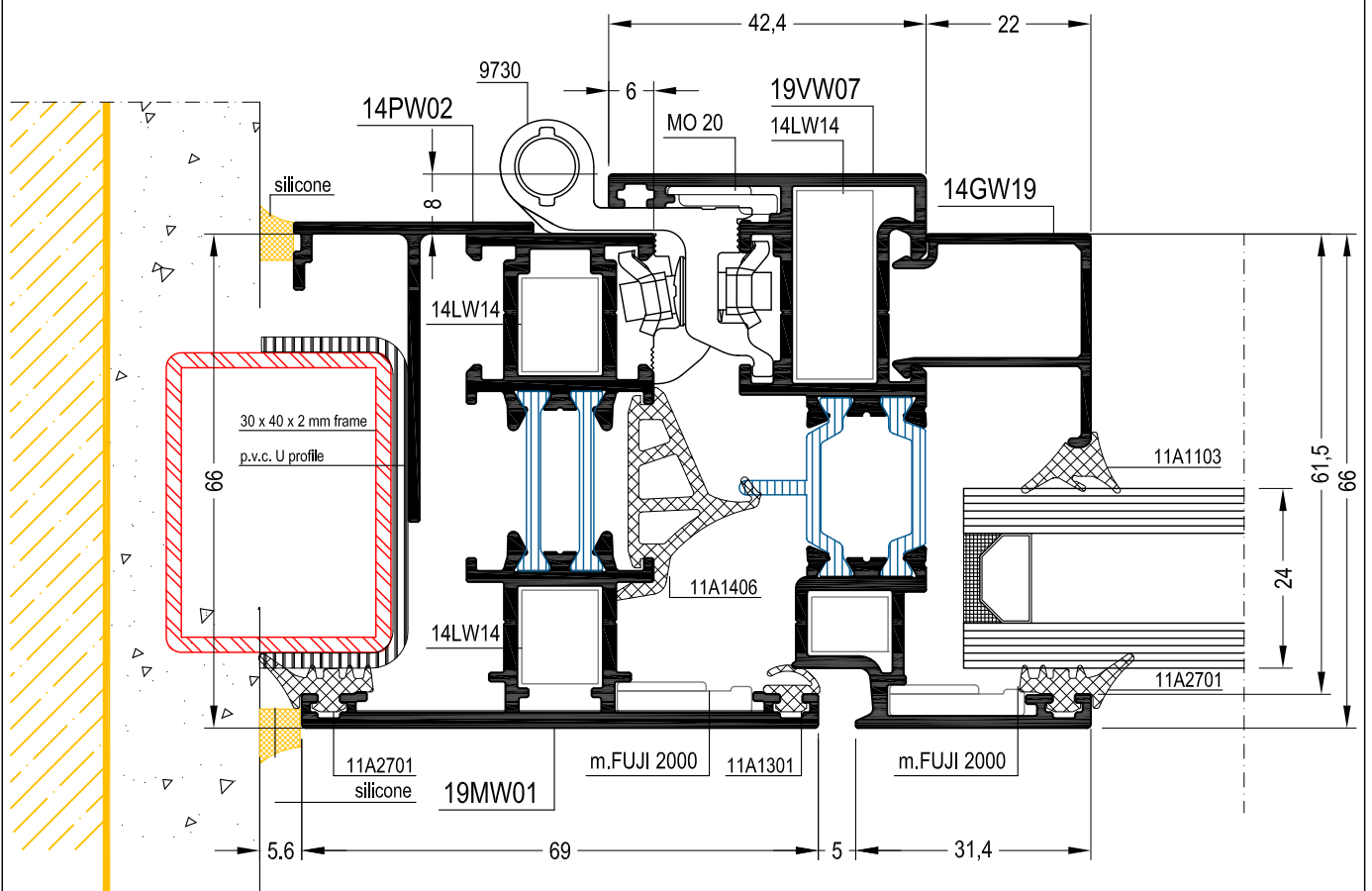
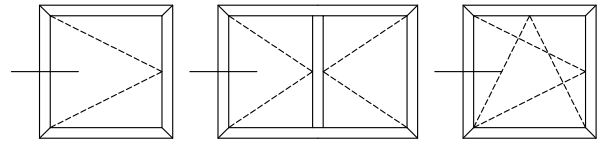

TURNING WINDOW

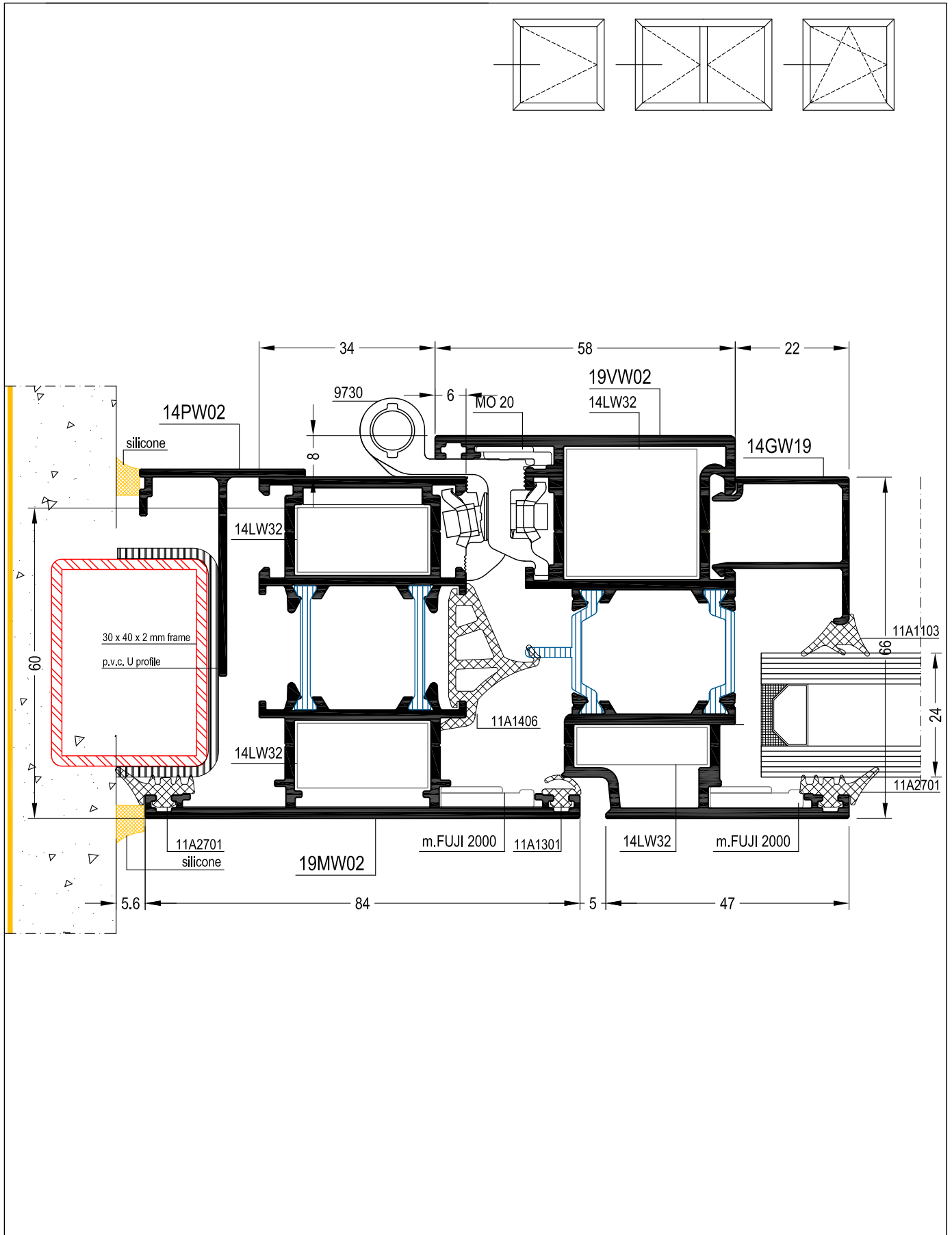

TURNING WINDOW

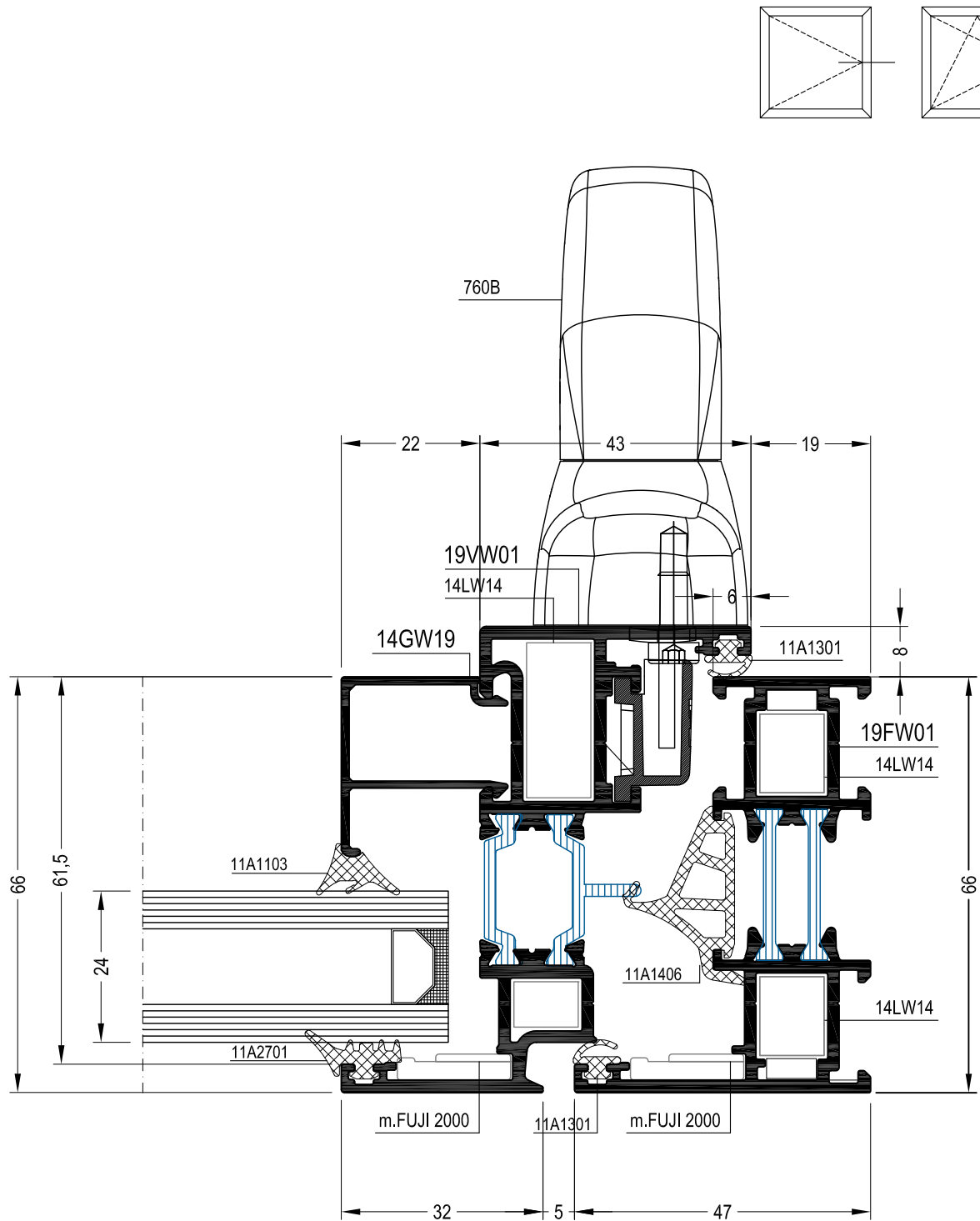

TURNING WINDOW

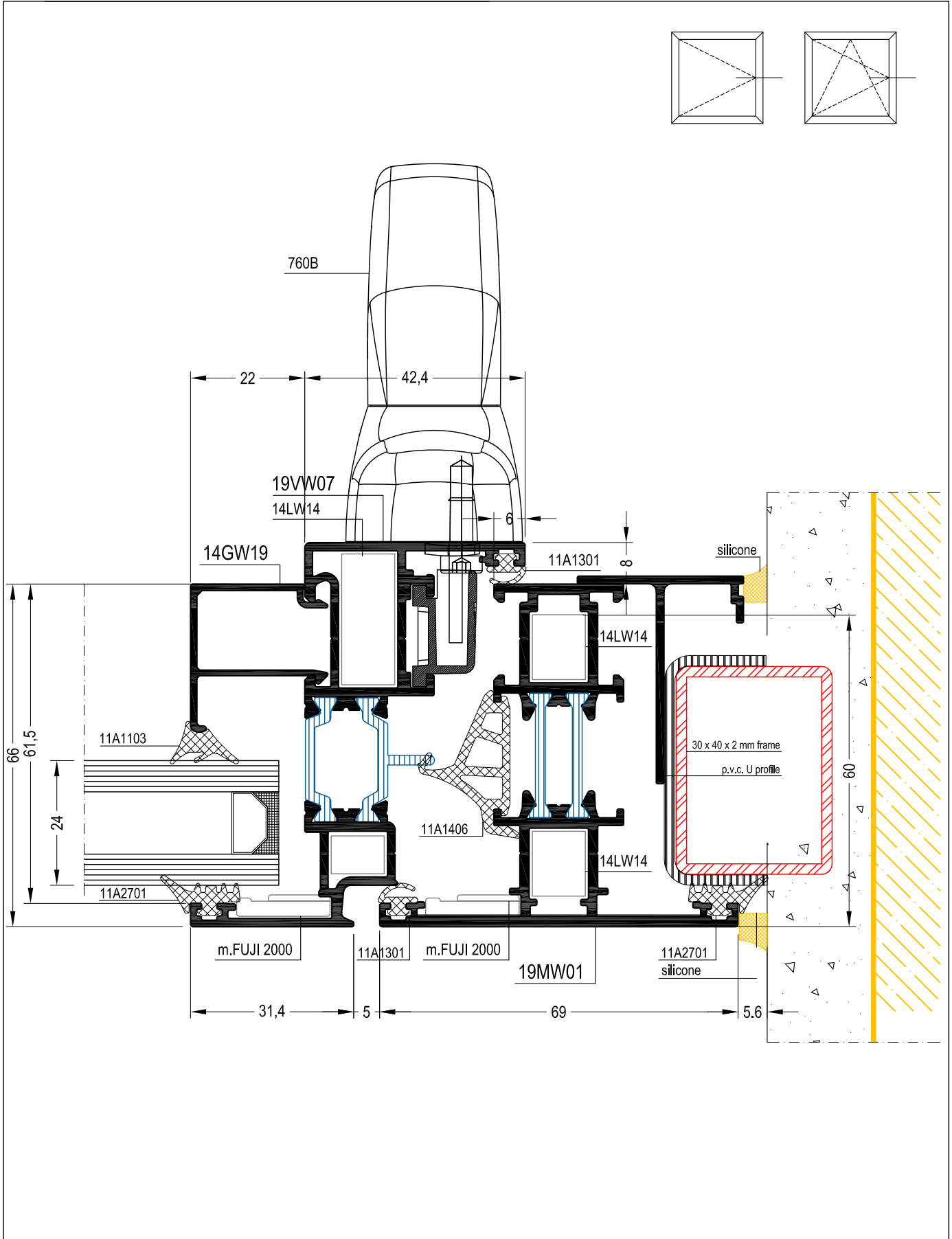

TURNING WINDOW

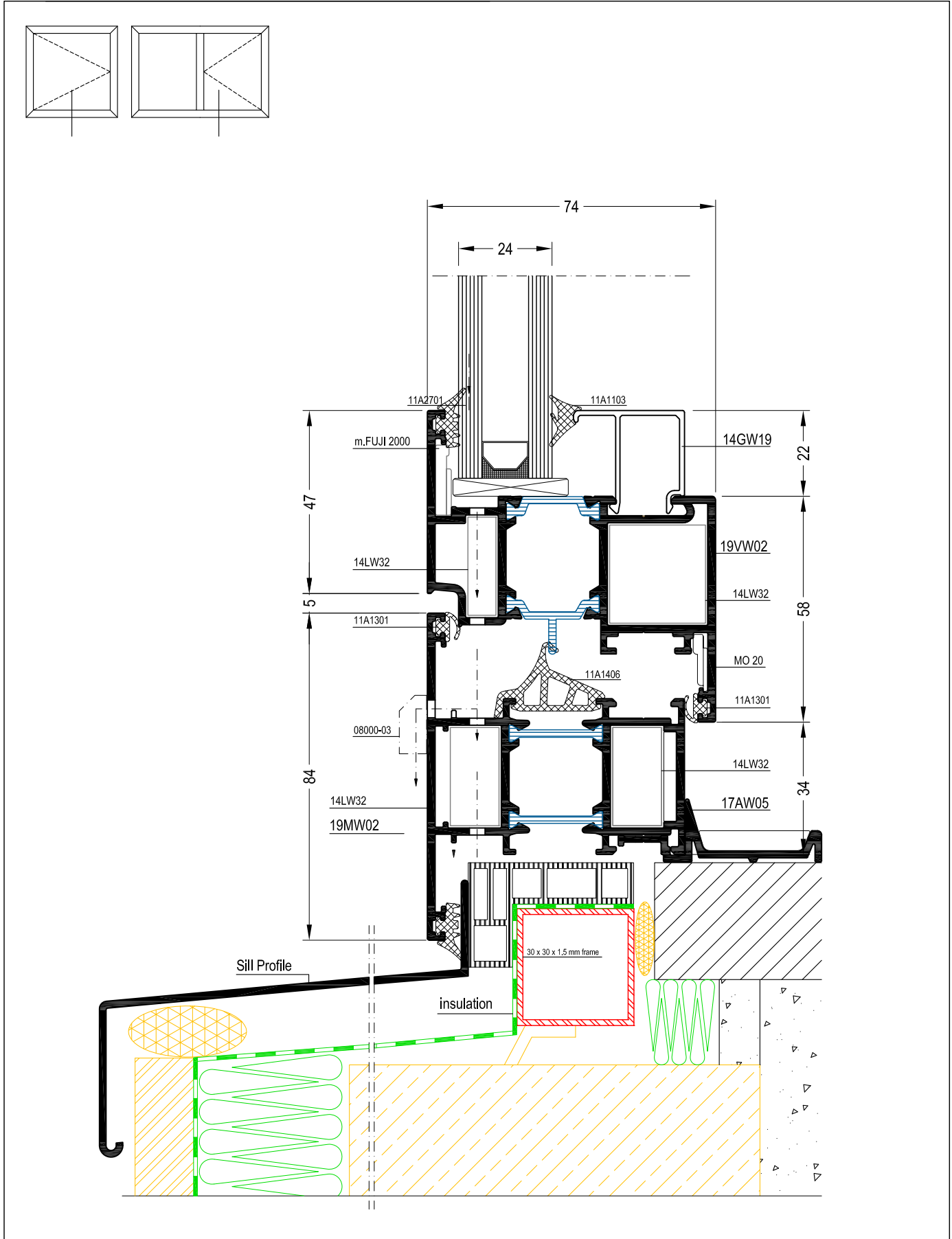

TURNING WINDOW

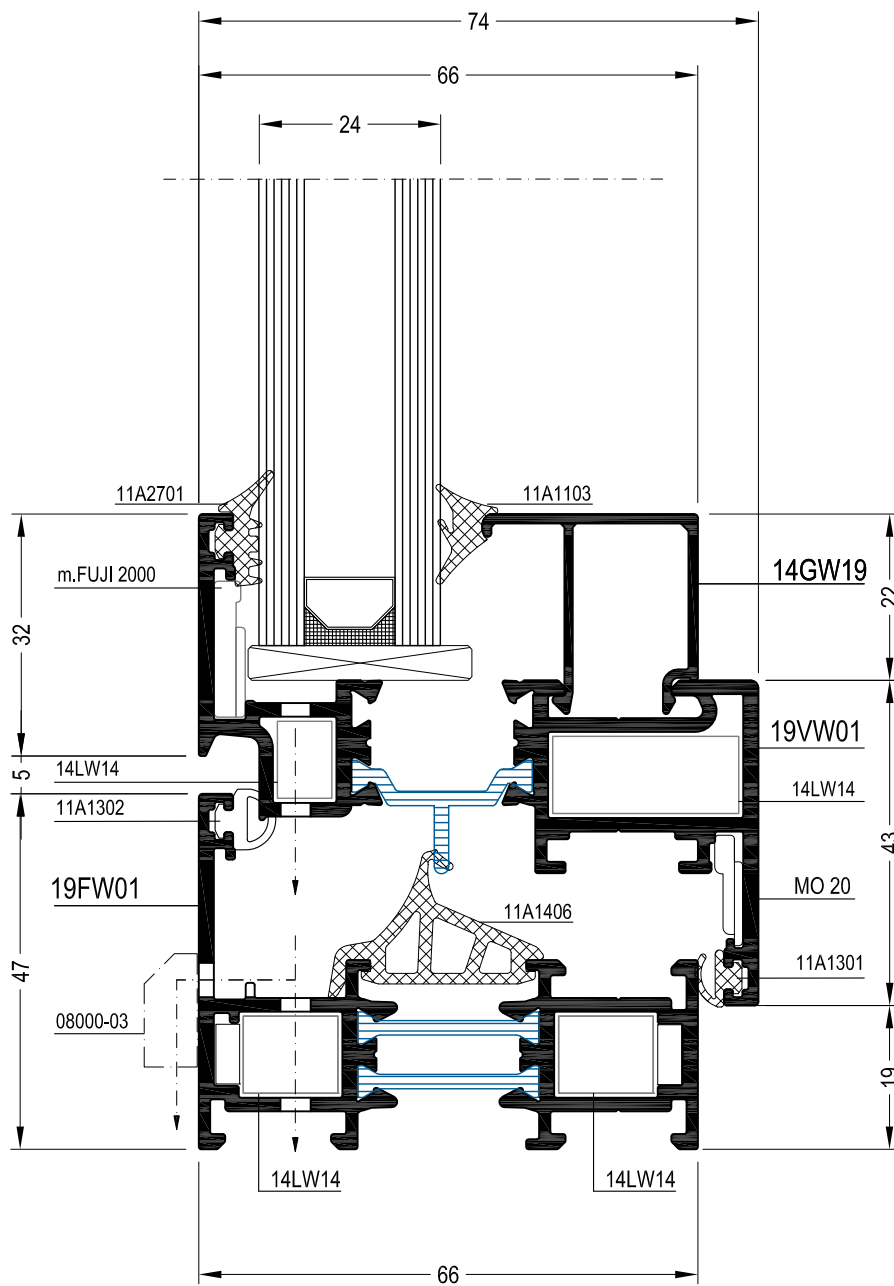
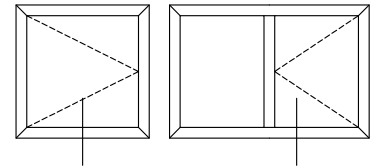

TURNING WINDOW

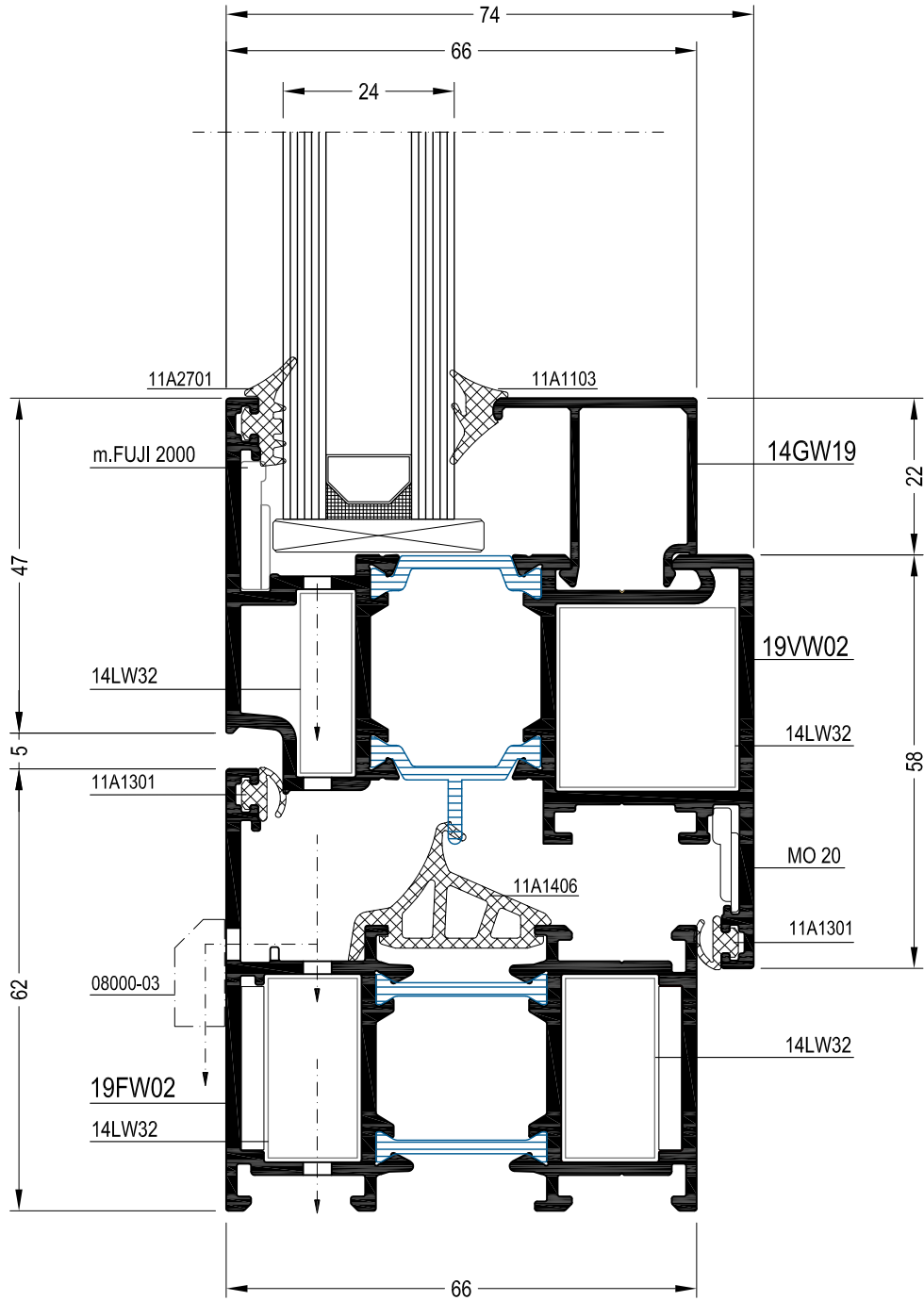
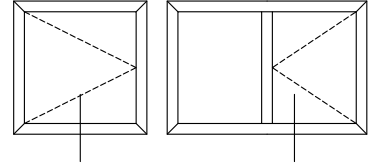

TURNING WINDOW

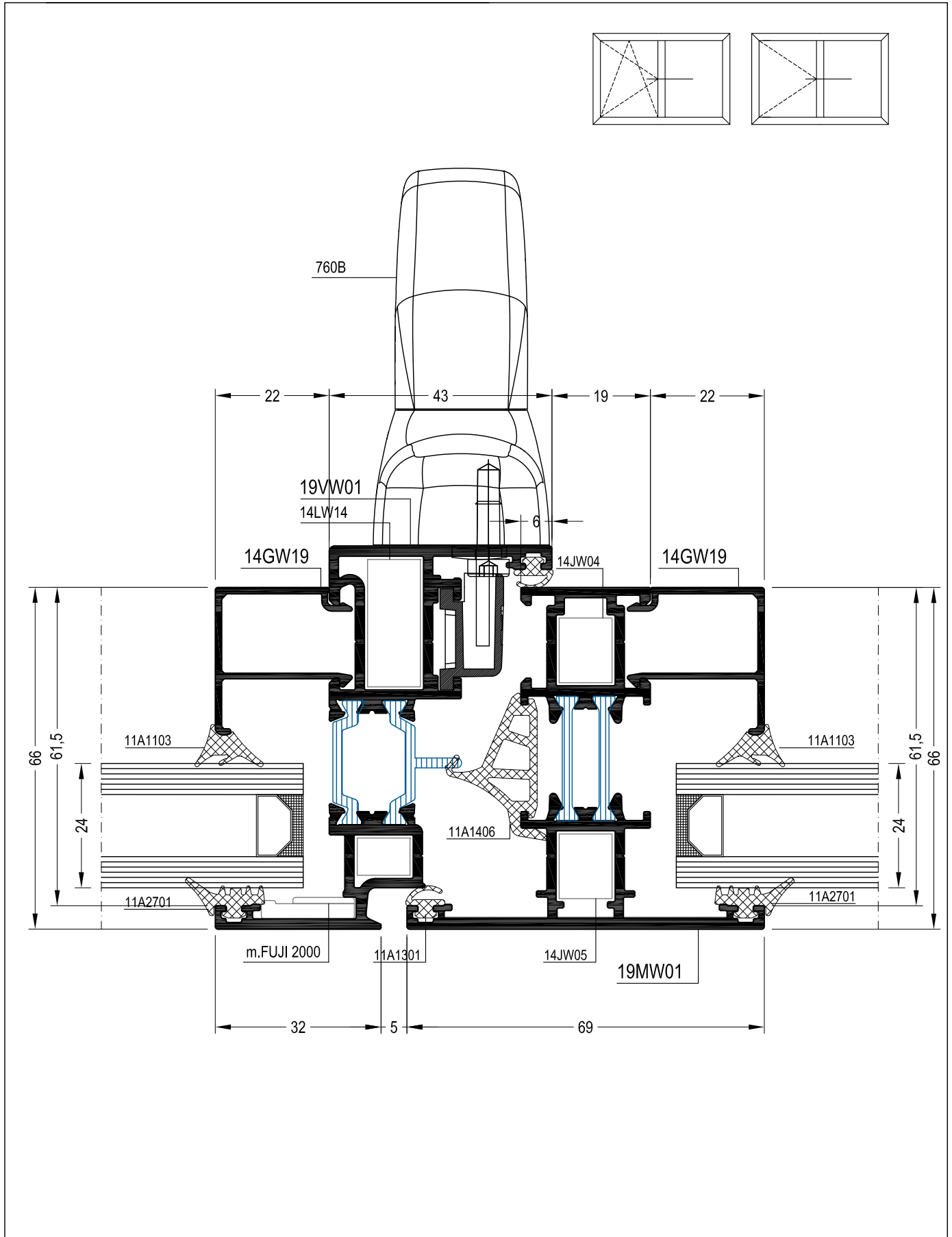

TURNING WINDOW

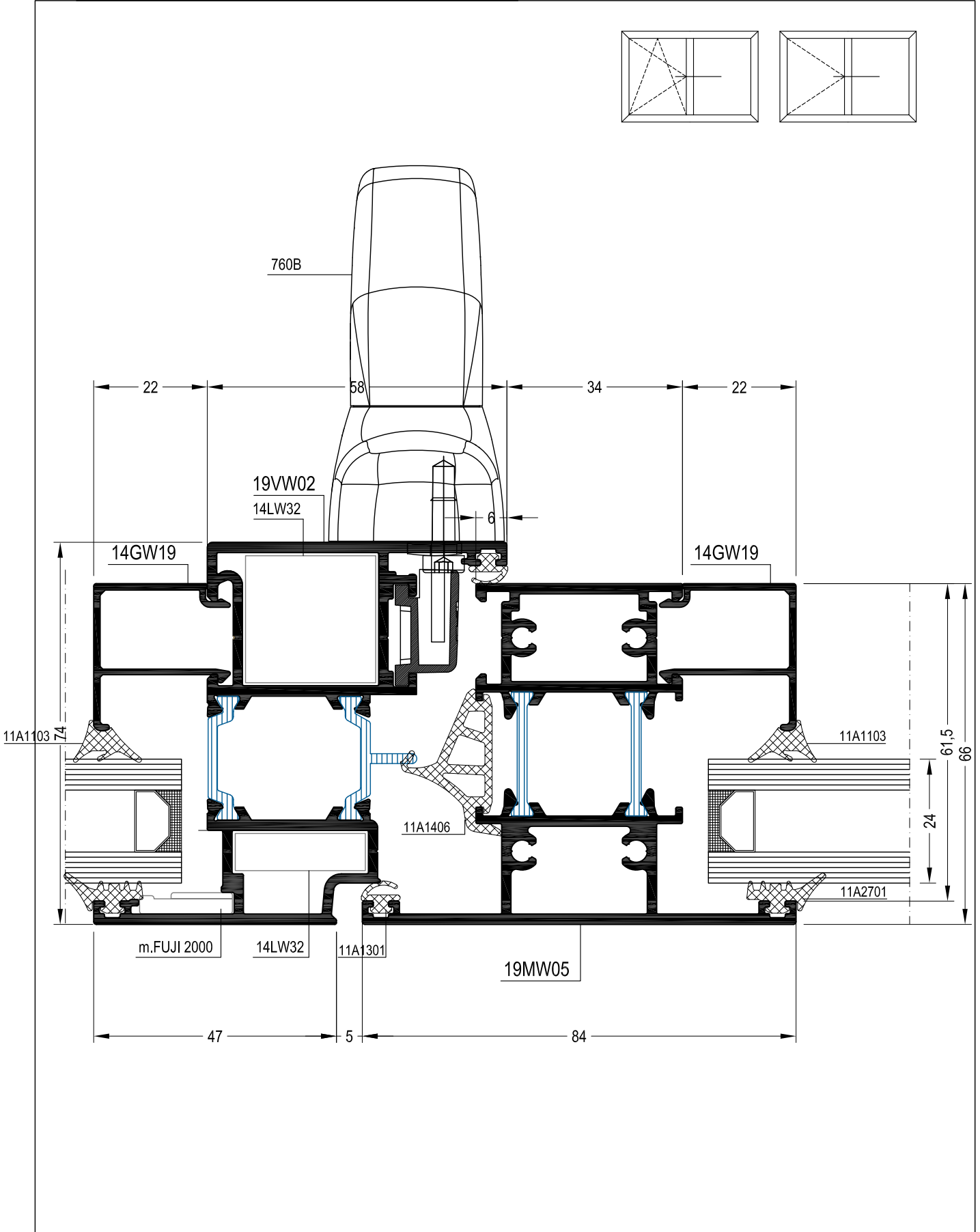

TURNING WINDOW

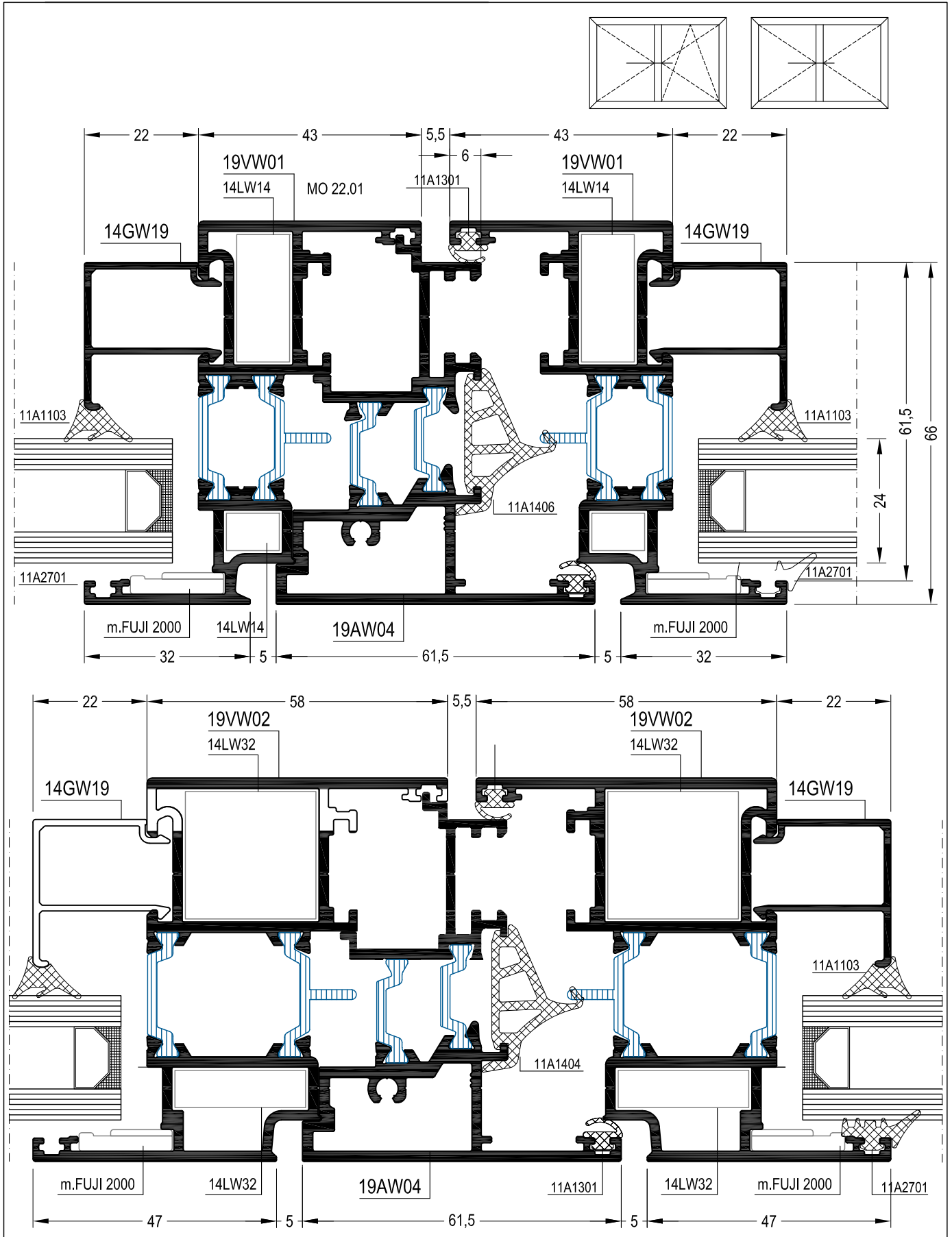

TURNING WINDOW

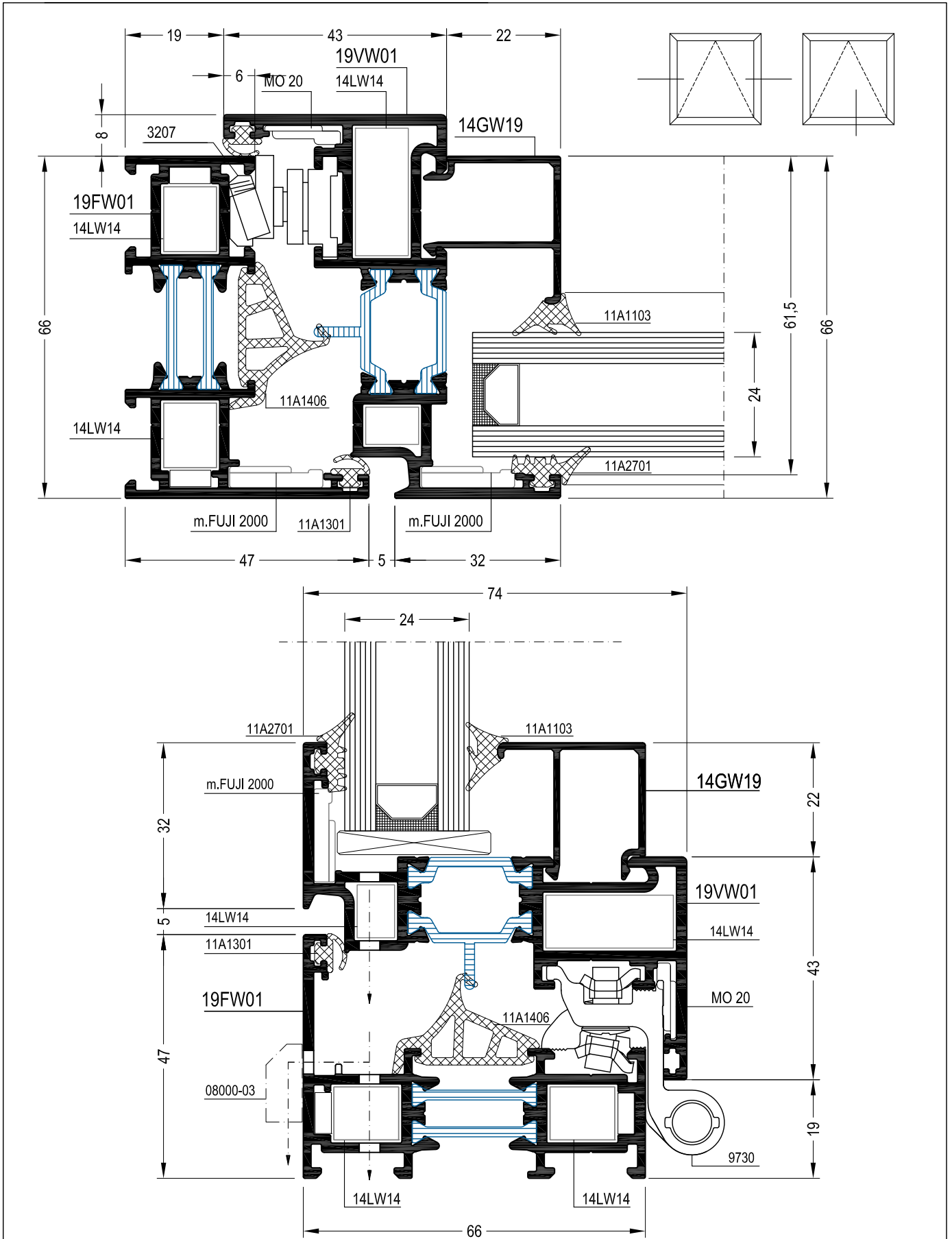

TURNING WINDOW

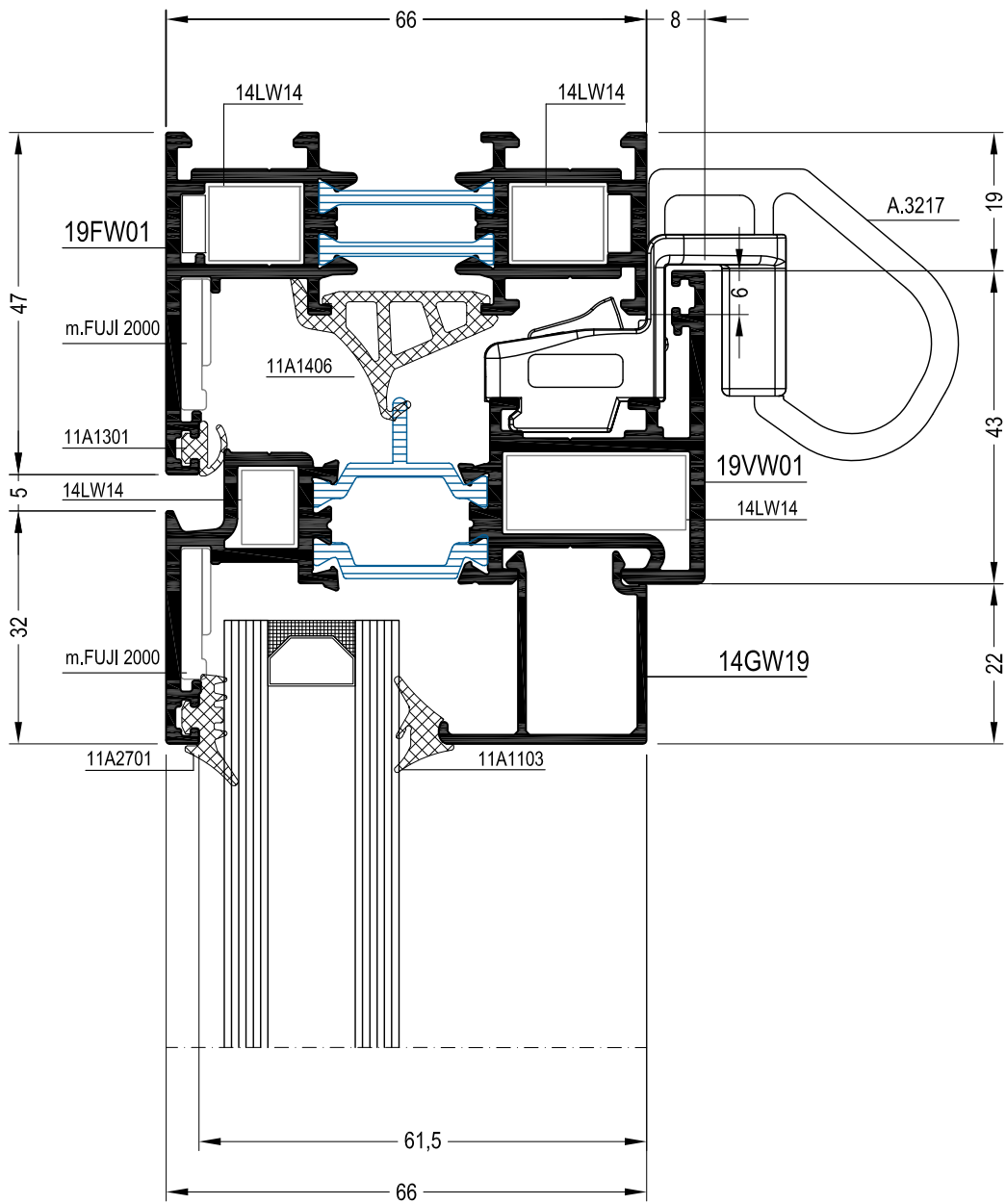
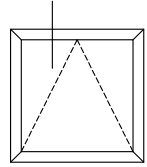

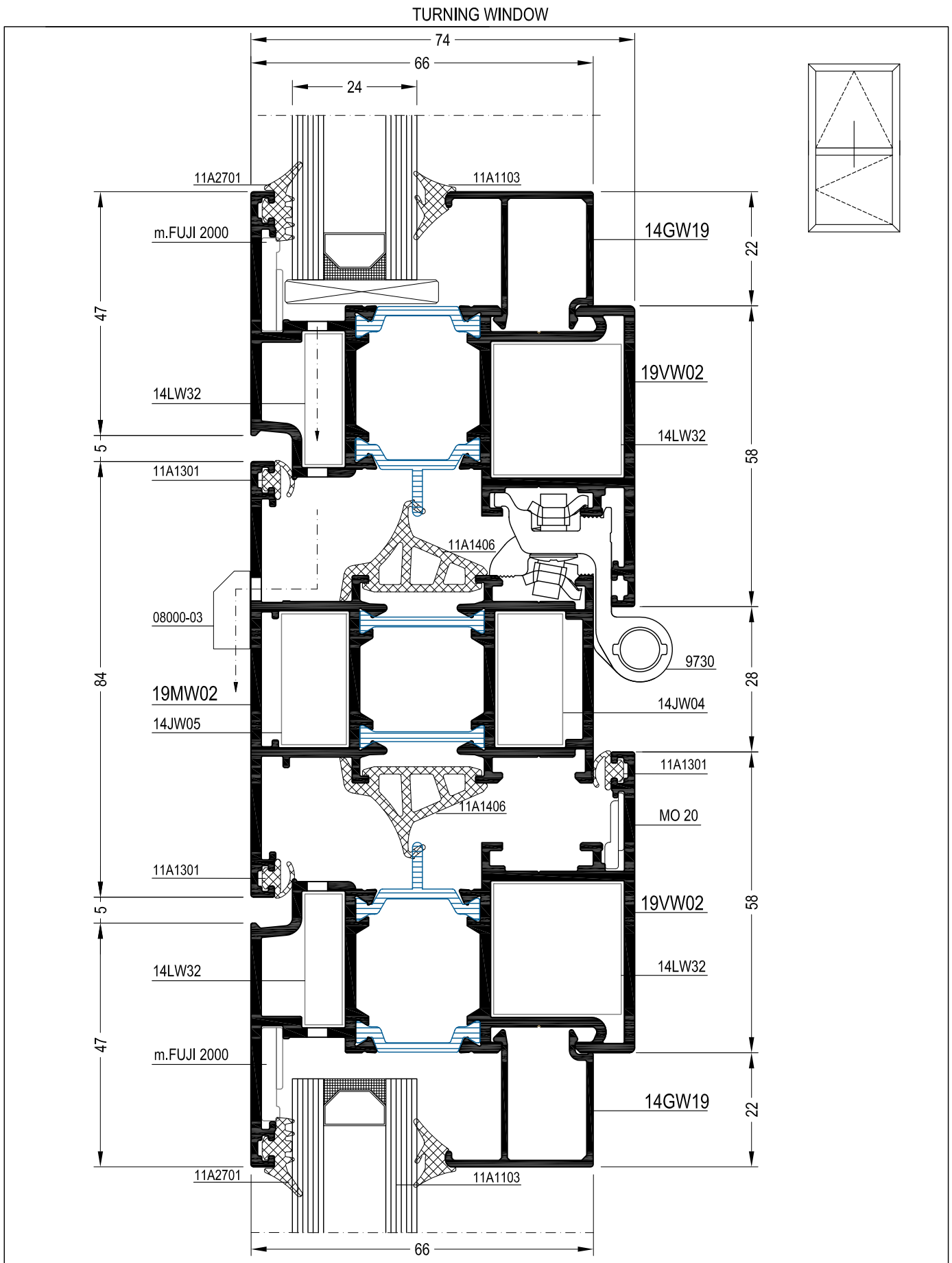

TURNING WINDOW

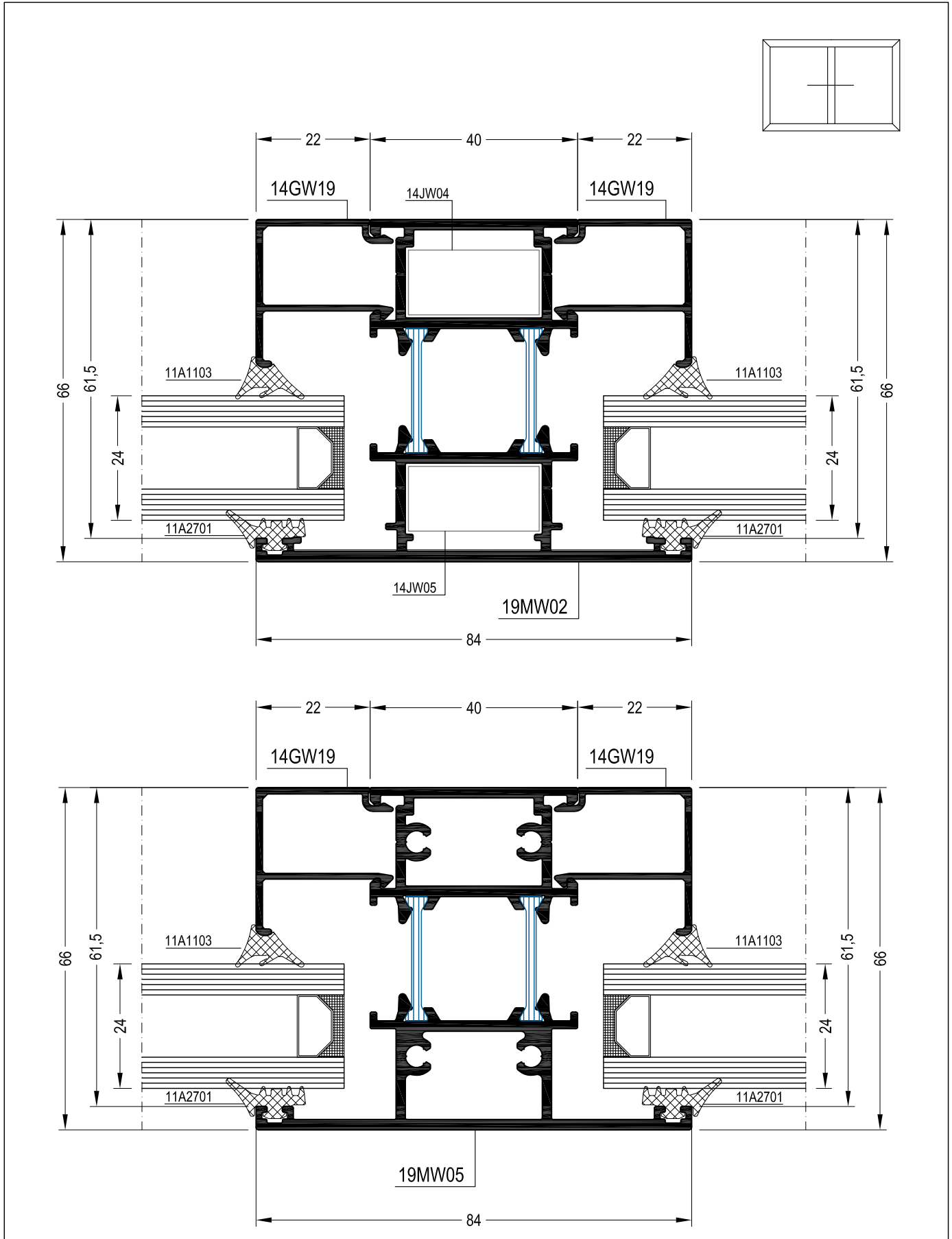

TURNING WINDOW

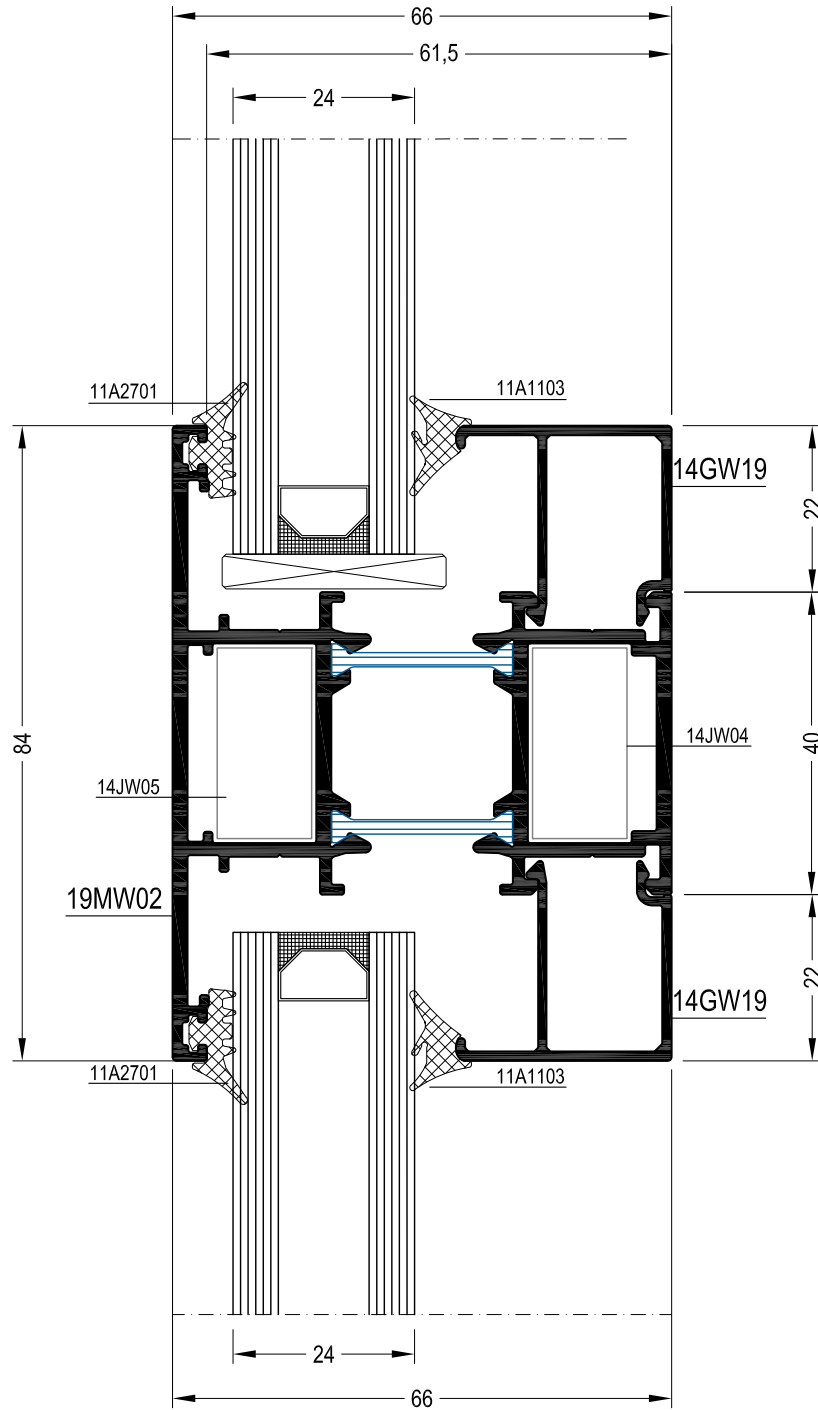
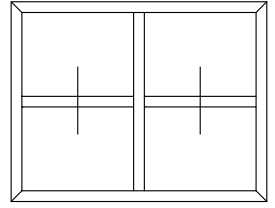

TURNING WINDOW

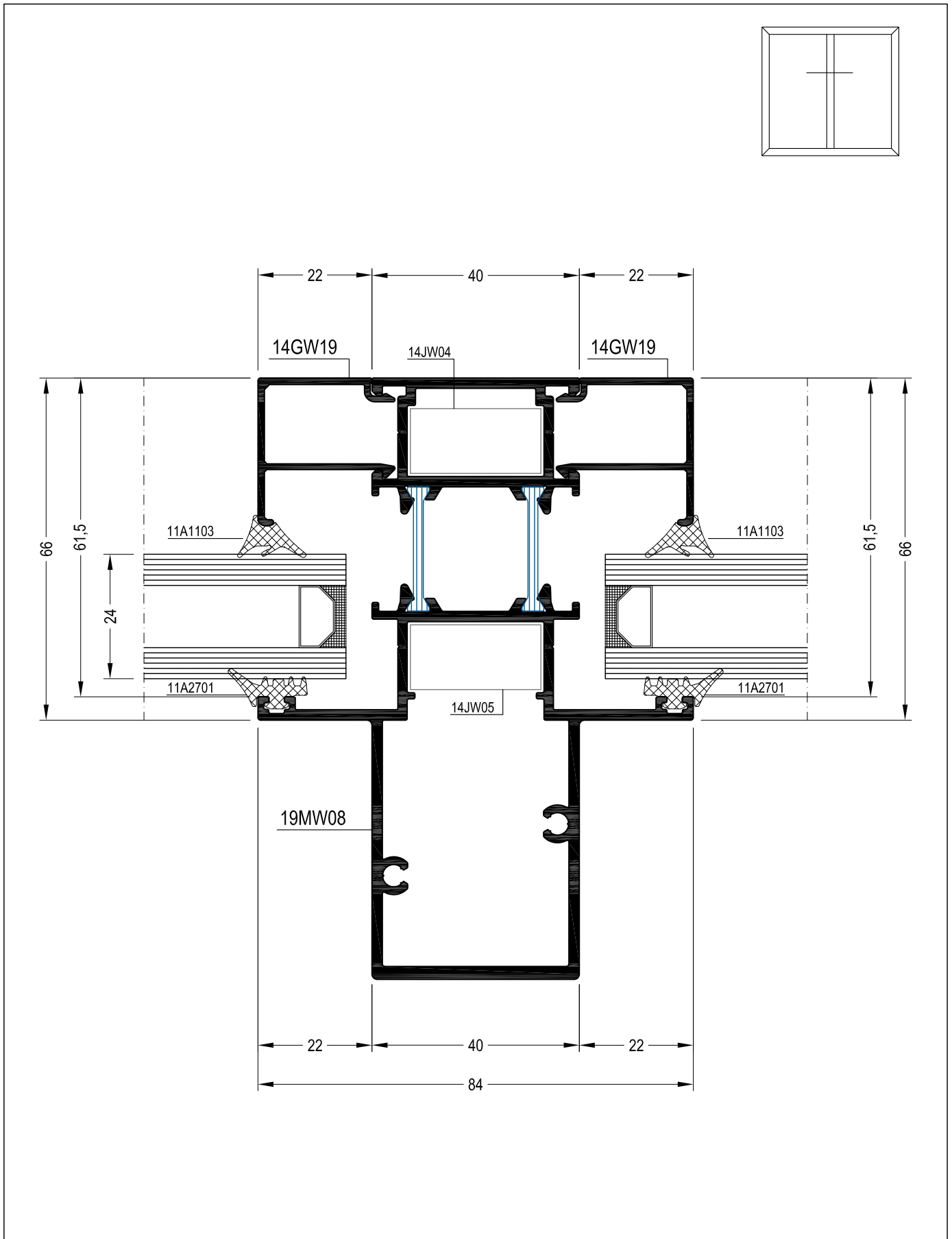

TURNING WINDOW

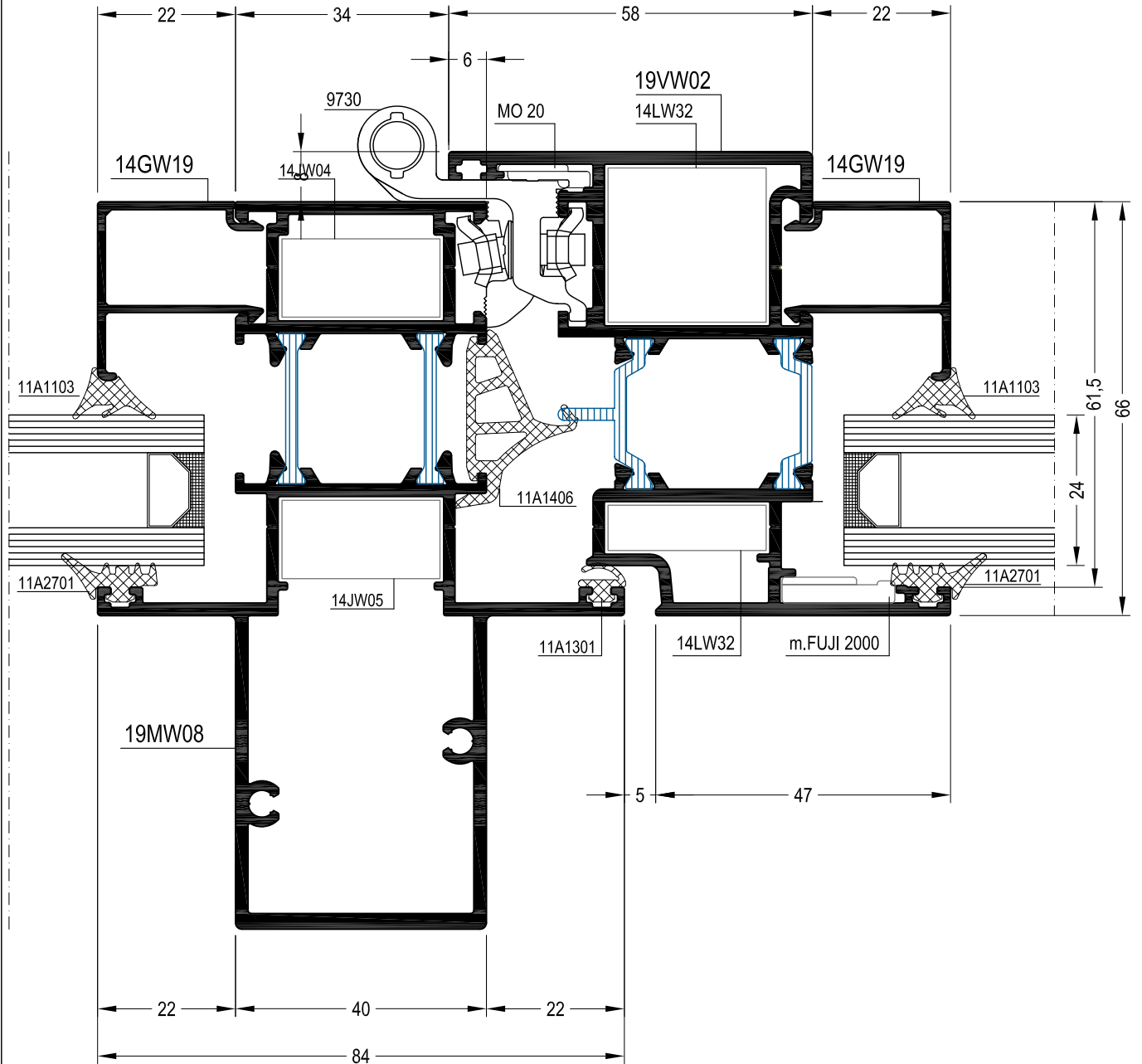
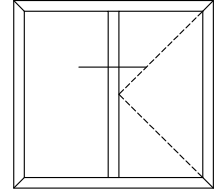

TURNING WINDOW

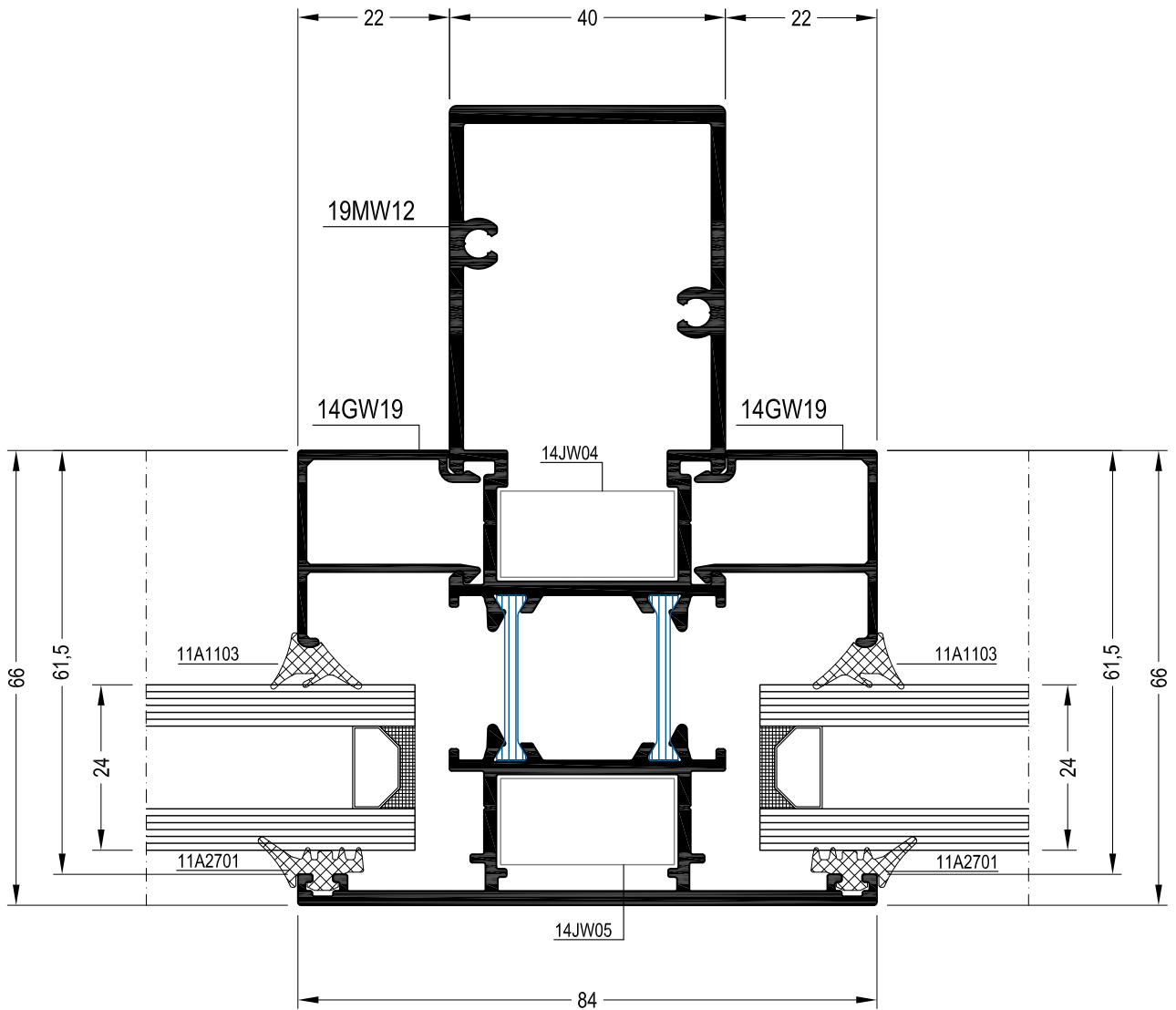
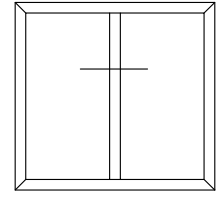

TURNING WINDOW

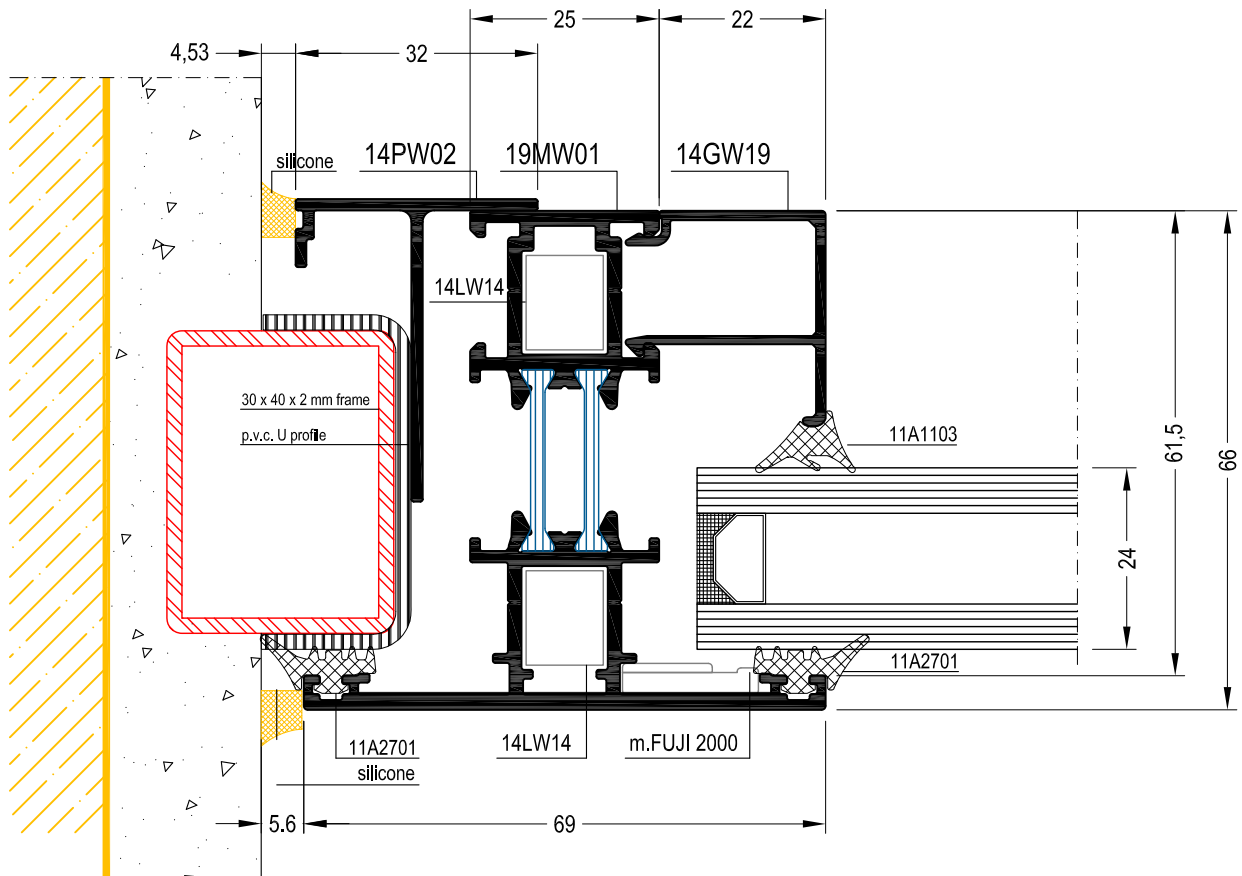
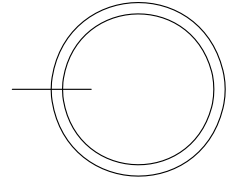

TURNING WINDOW

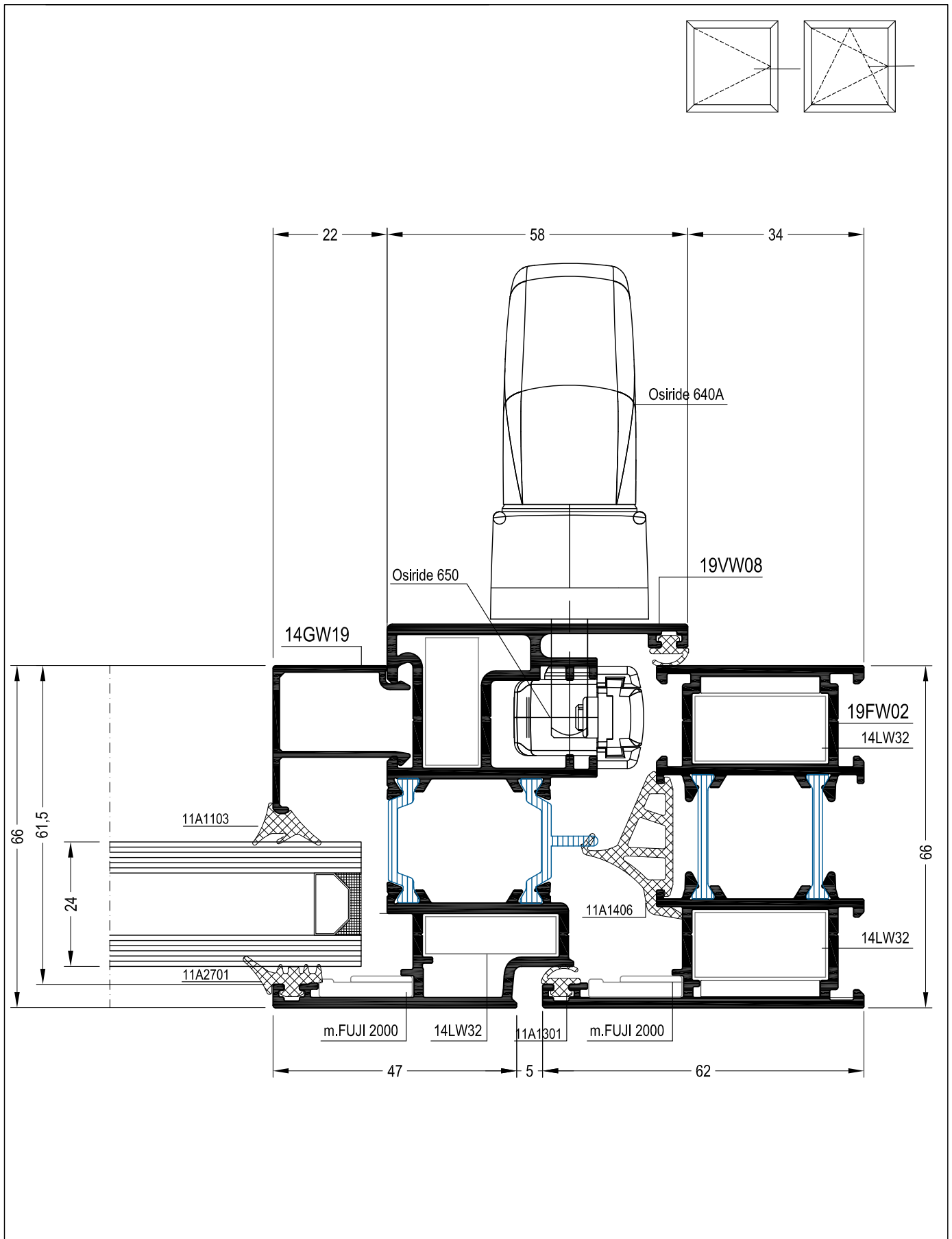

TURNING WINDOW

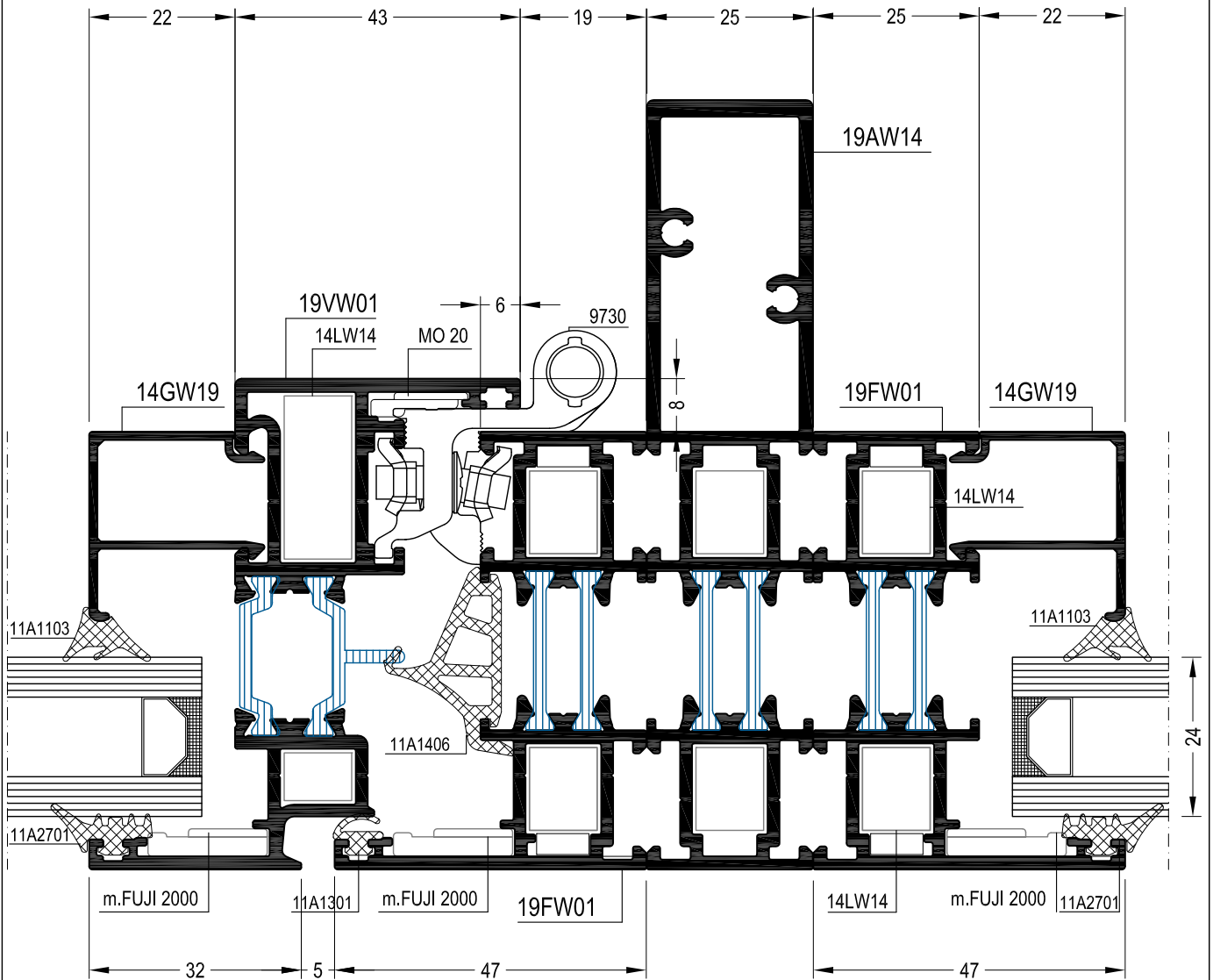
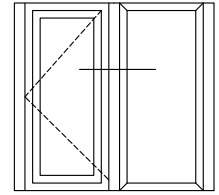

TURNING WINDOW FOR P.V.C. ACCESSORIES

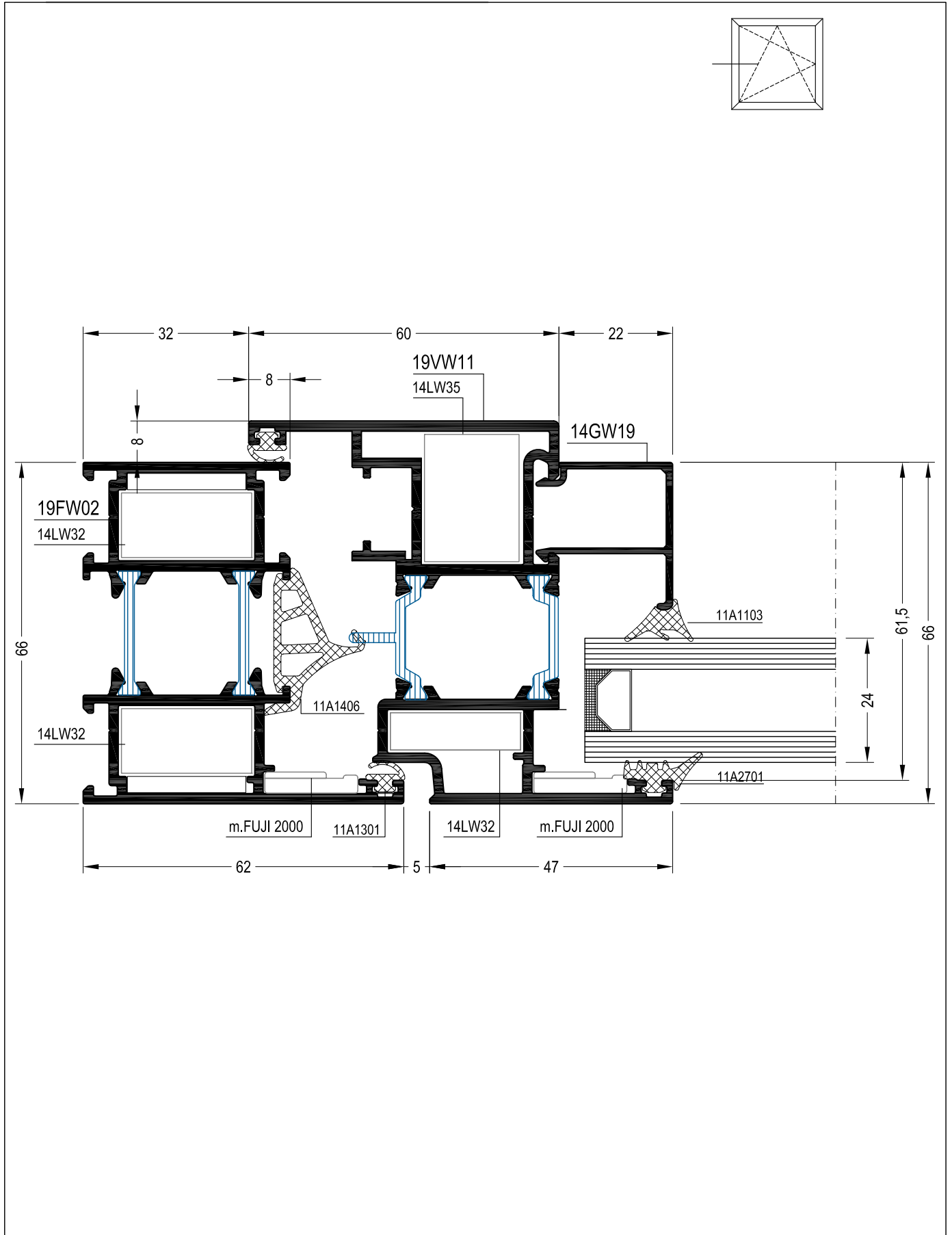

TURNING WINDOW

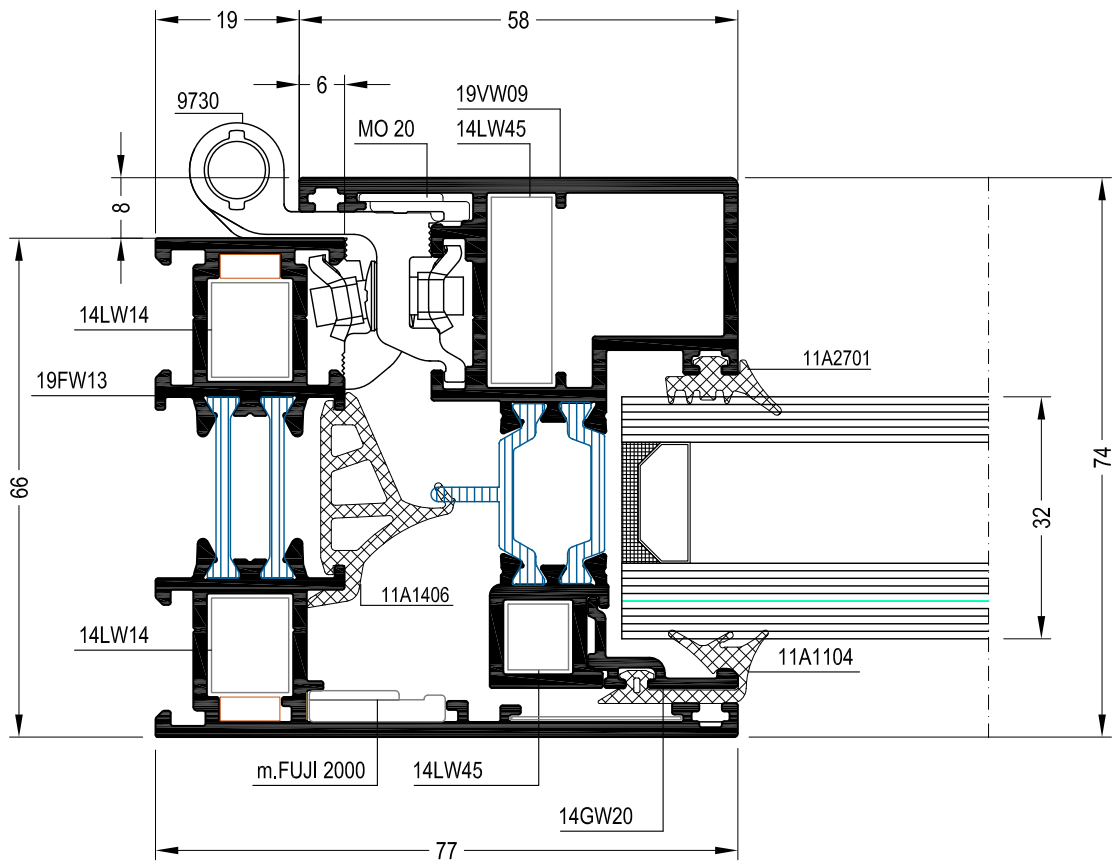
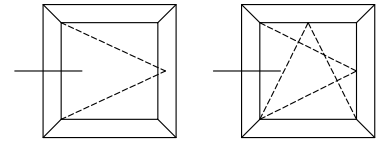

TURNING WINDOW

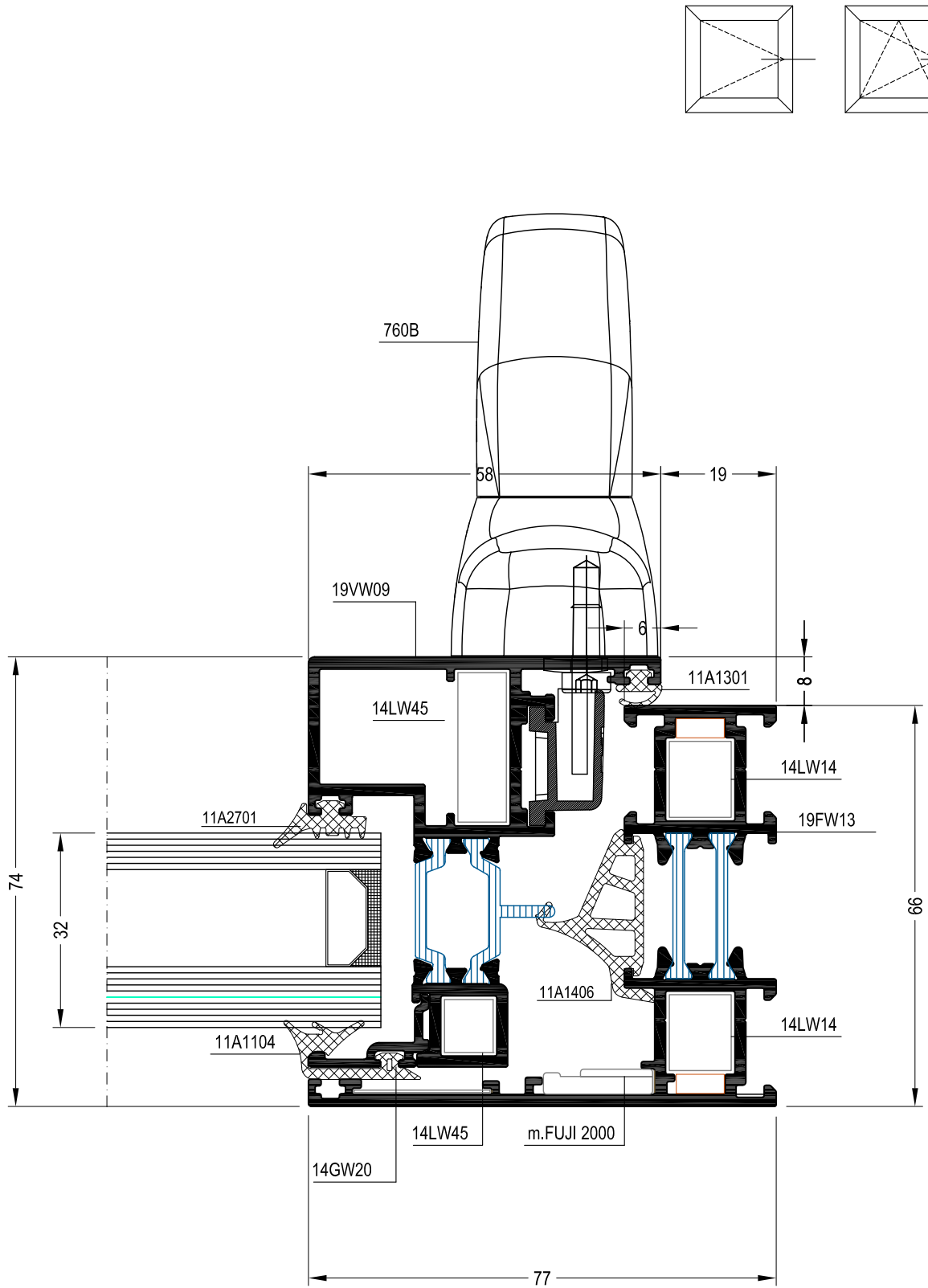

TURNING WINDOW

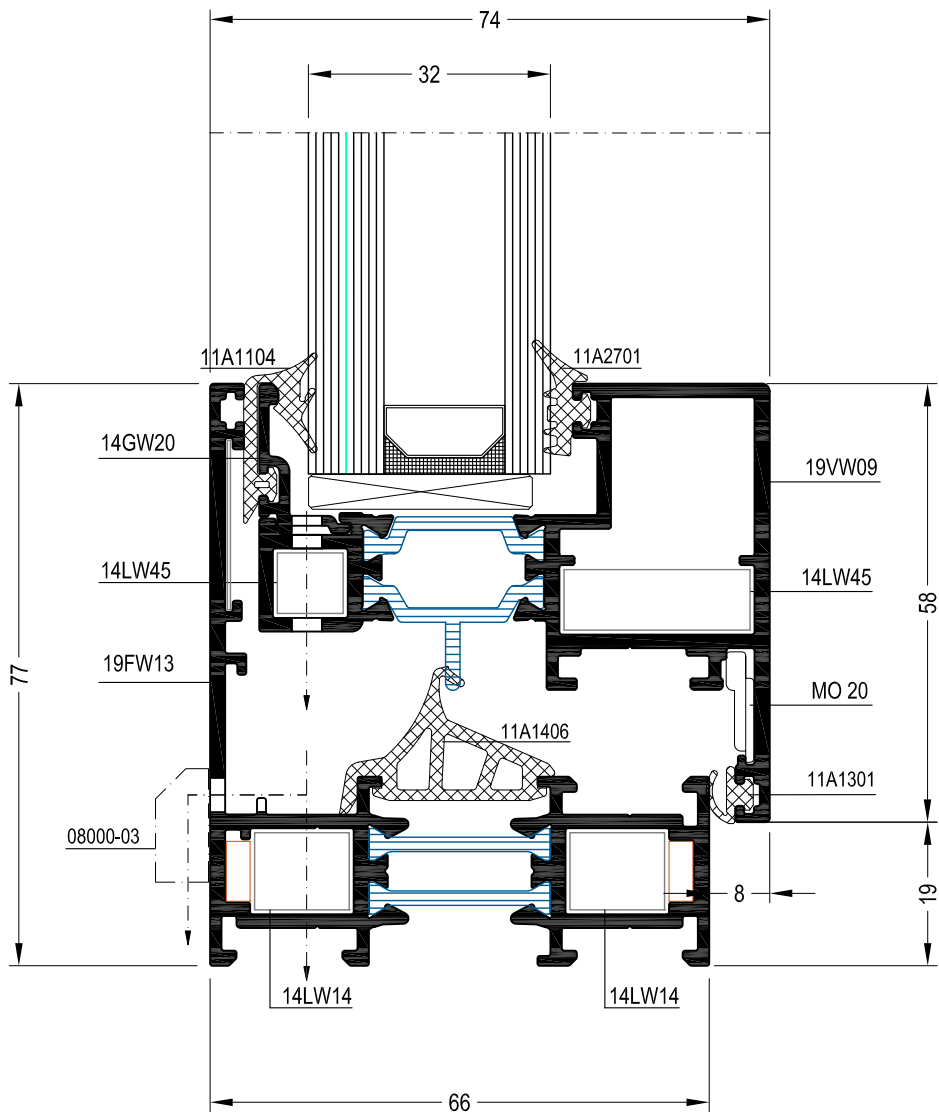
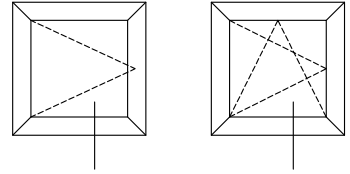

TURNING WINDOW

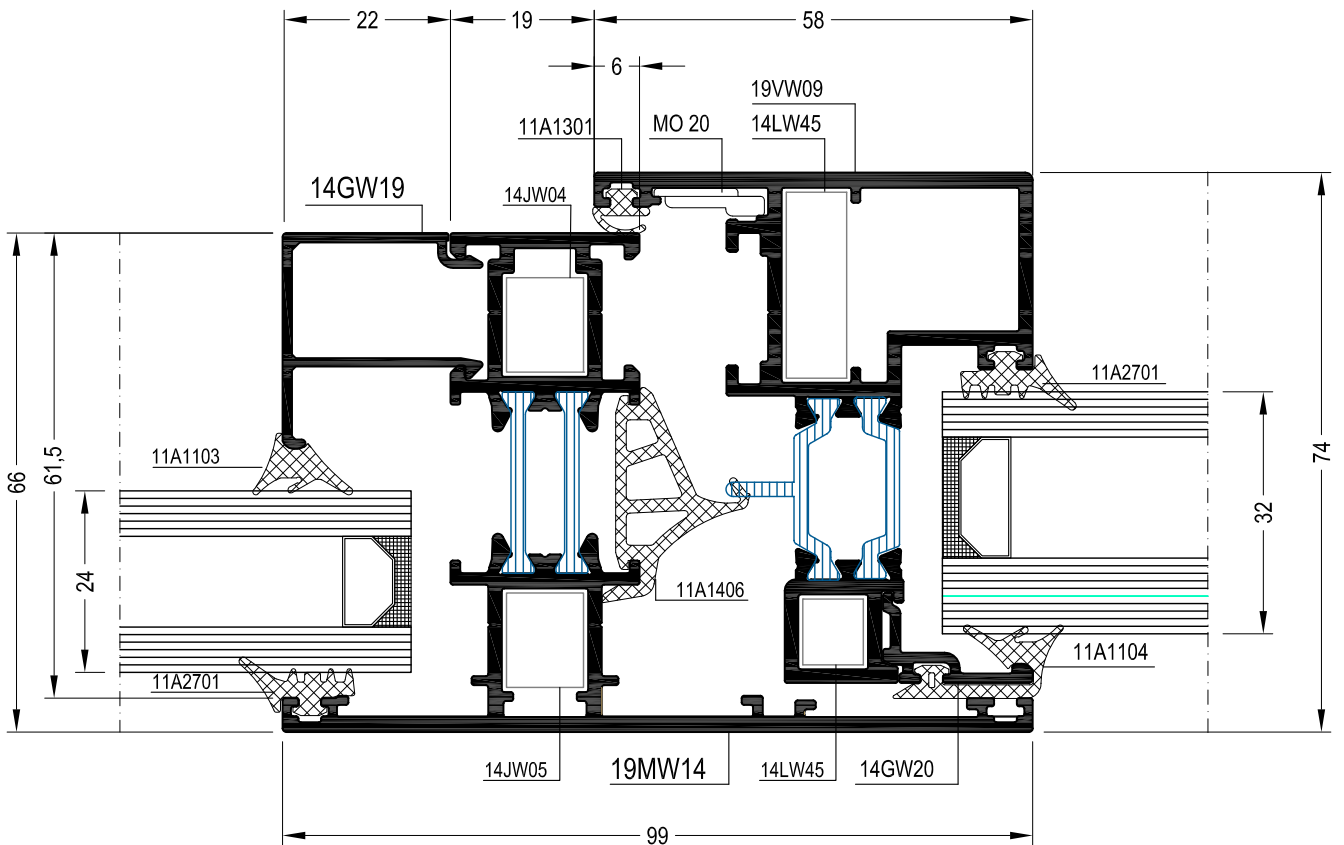
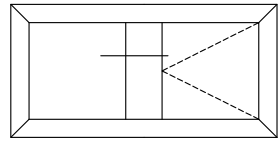

TURNING WINDOW

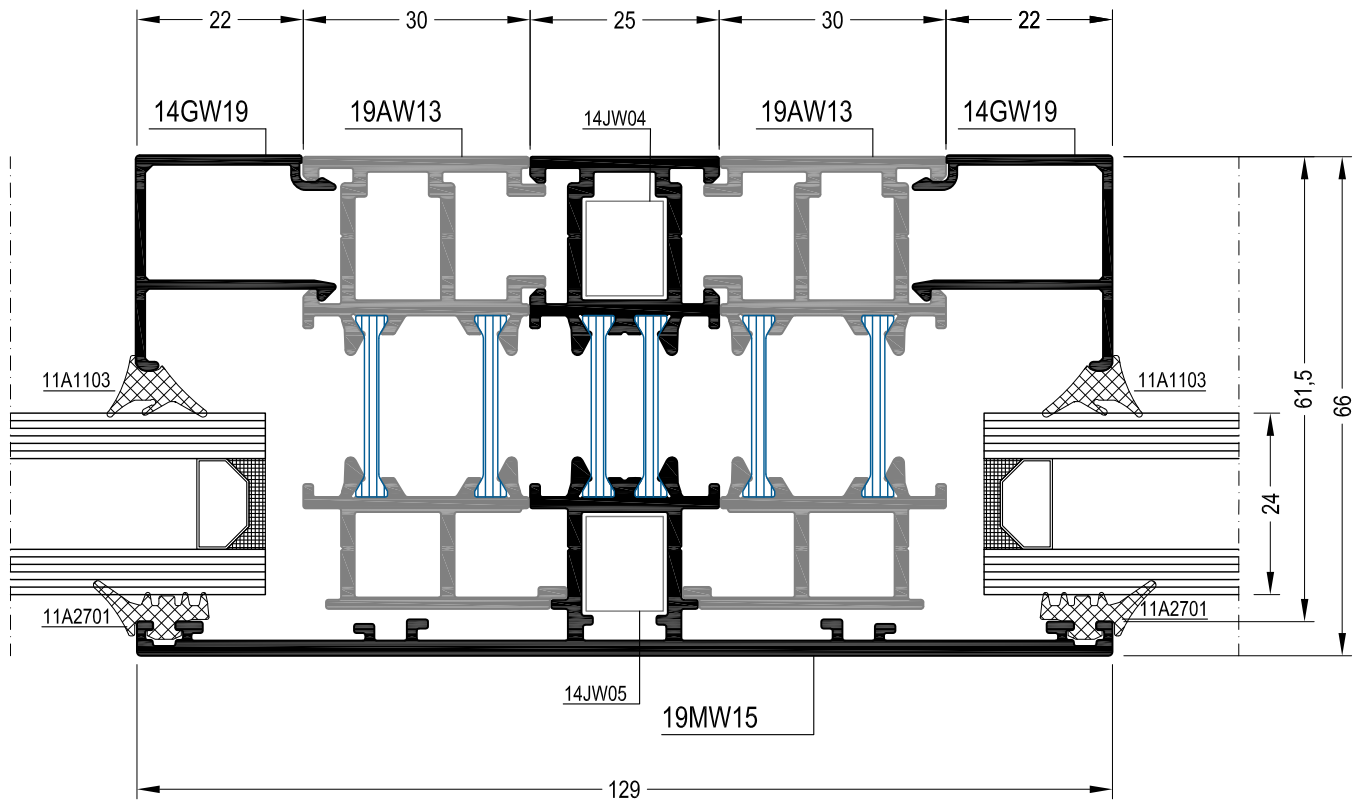
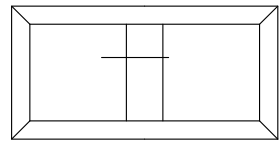

TURNING WINDOW

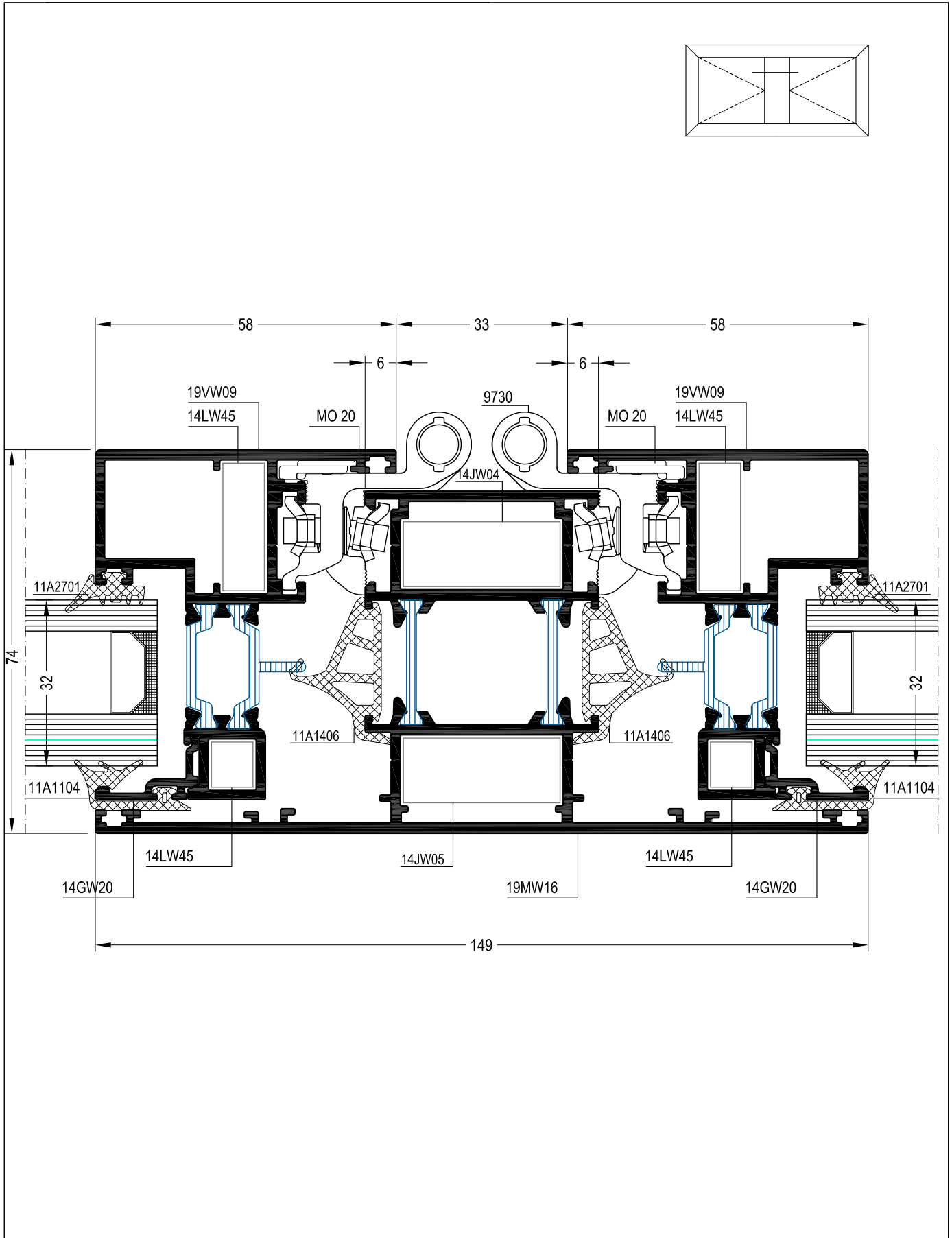

TURNING WINDOW

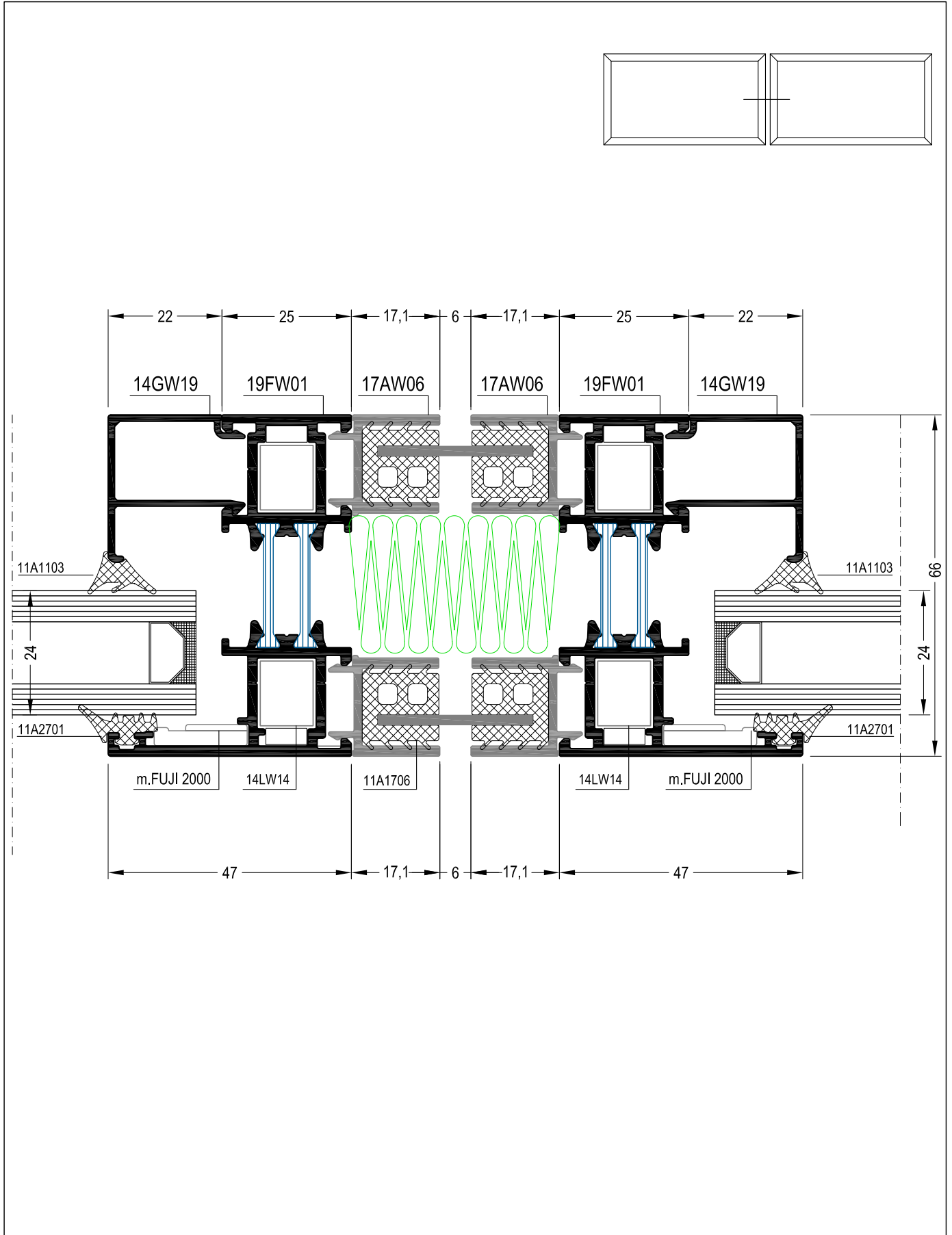

TURNING WINDOW

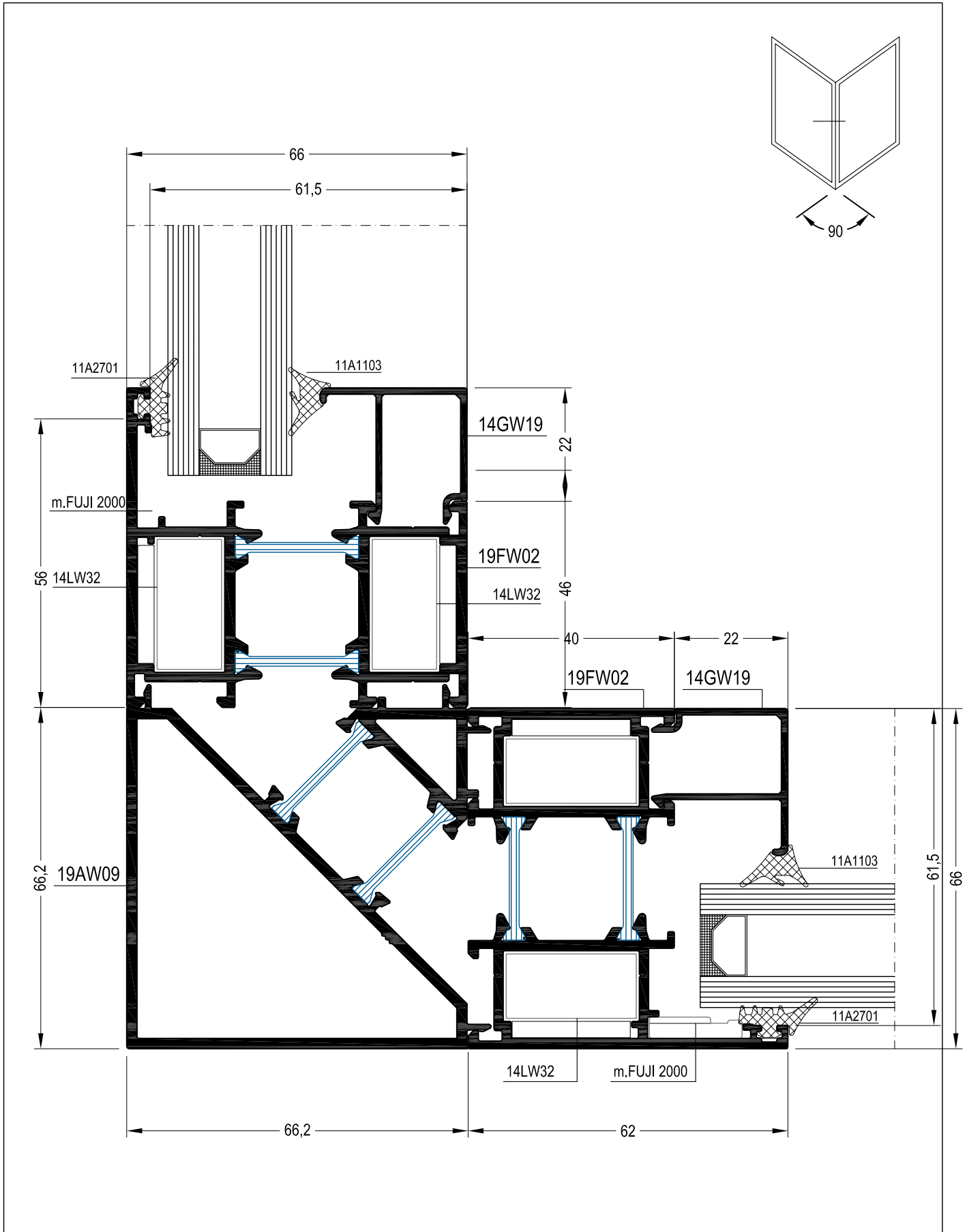

TURNING WINDOW

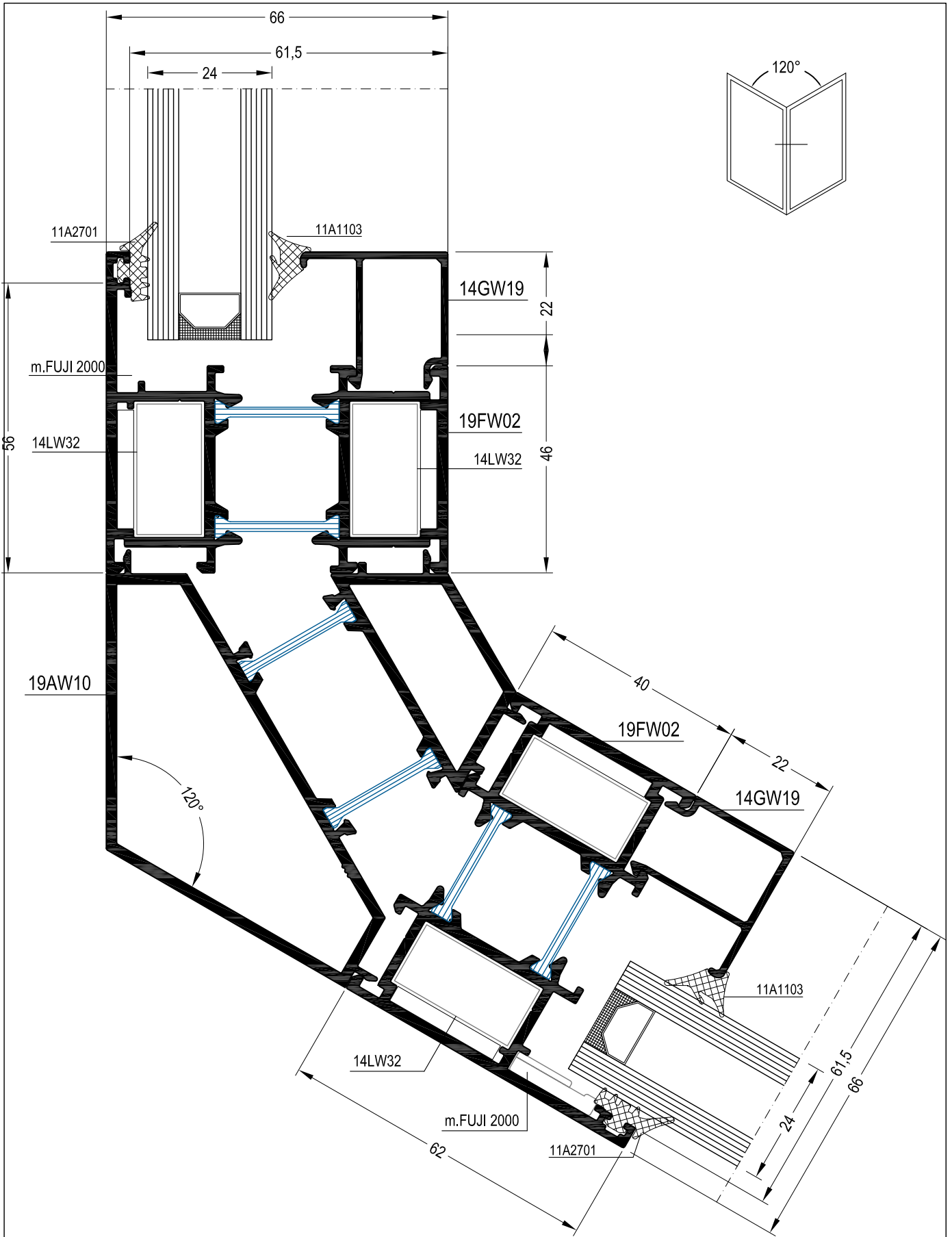

TURNING WINDOW

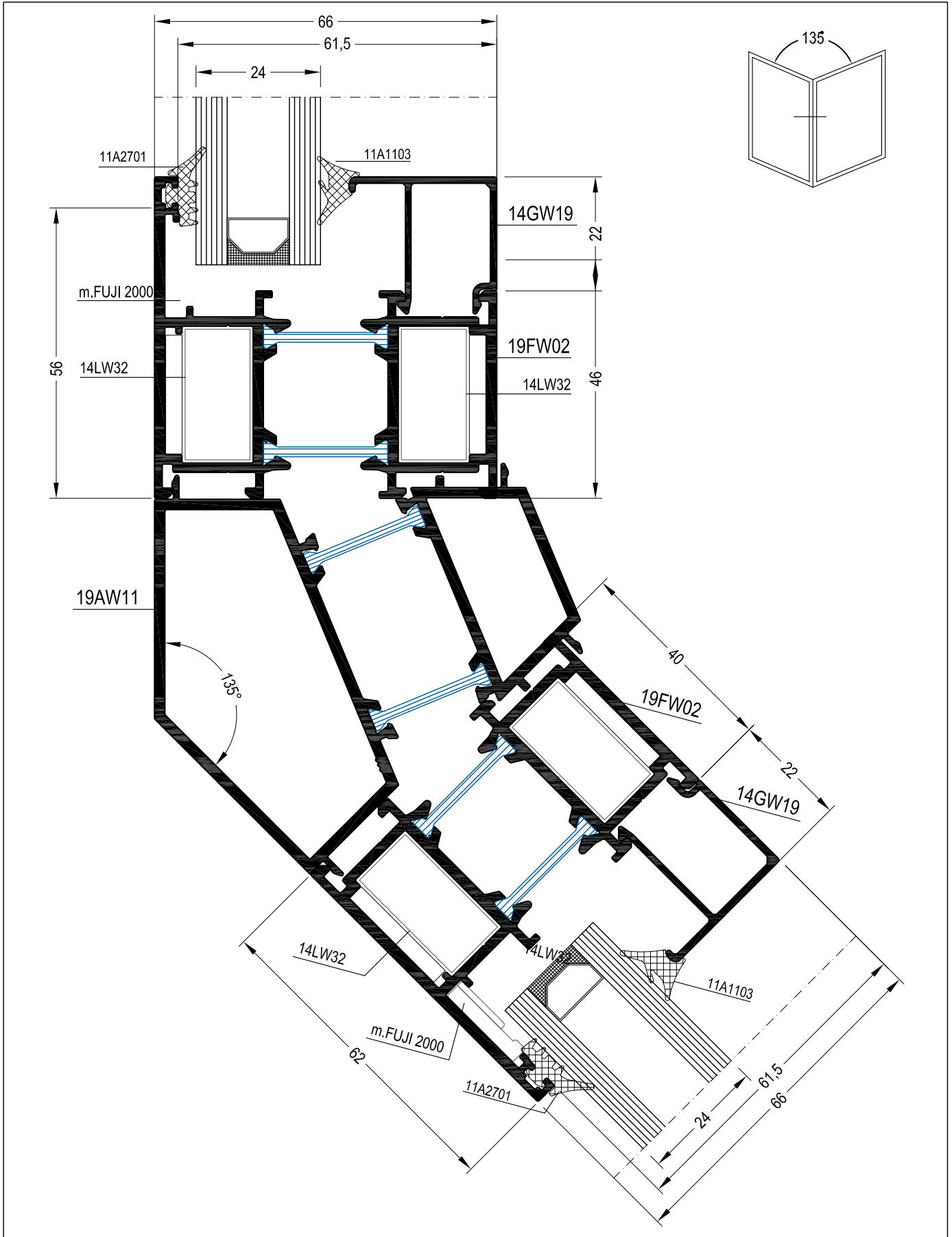

TURNING WINDOW

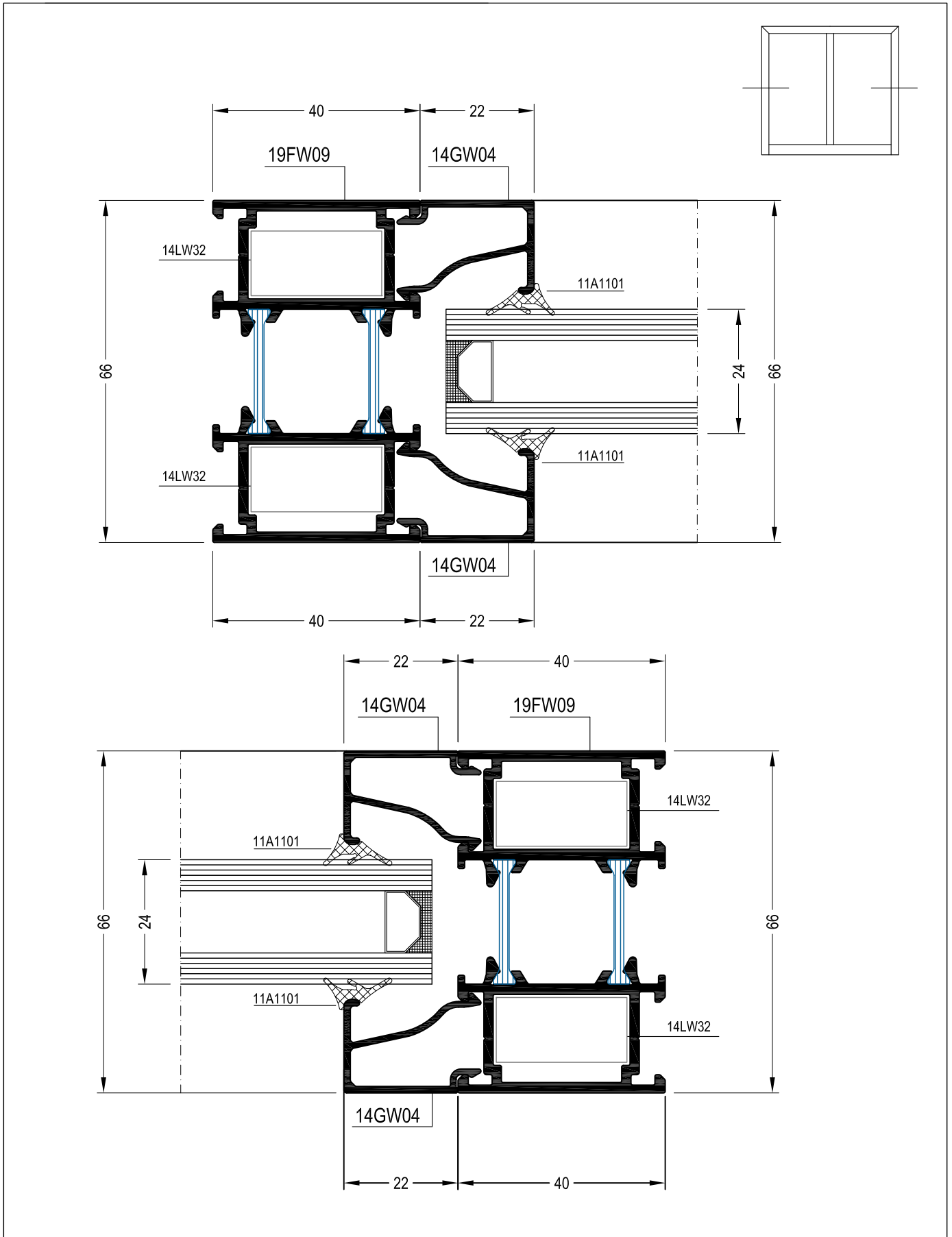

TURNING WINDOW

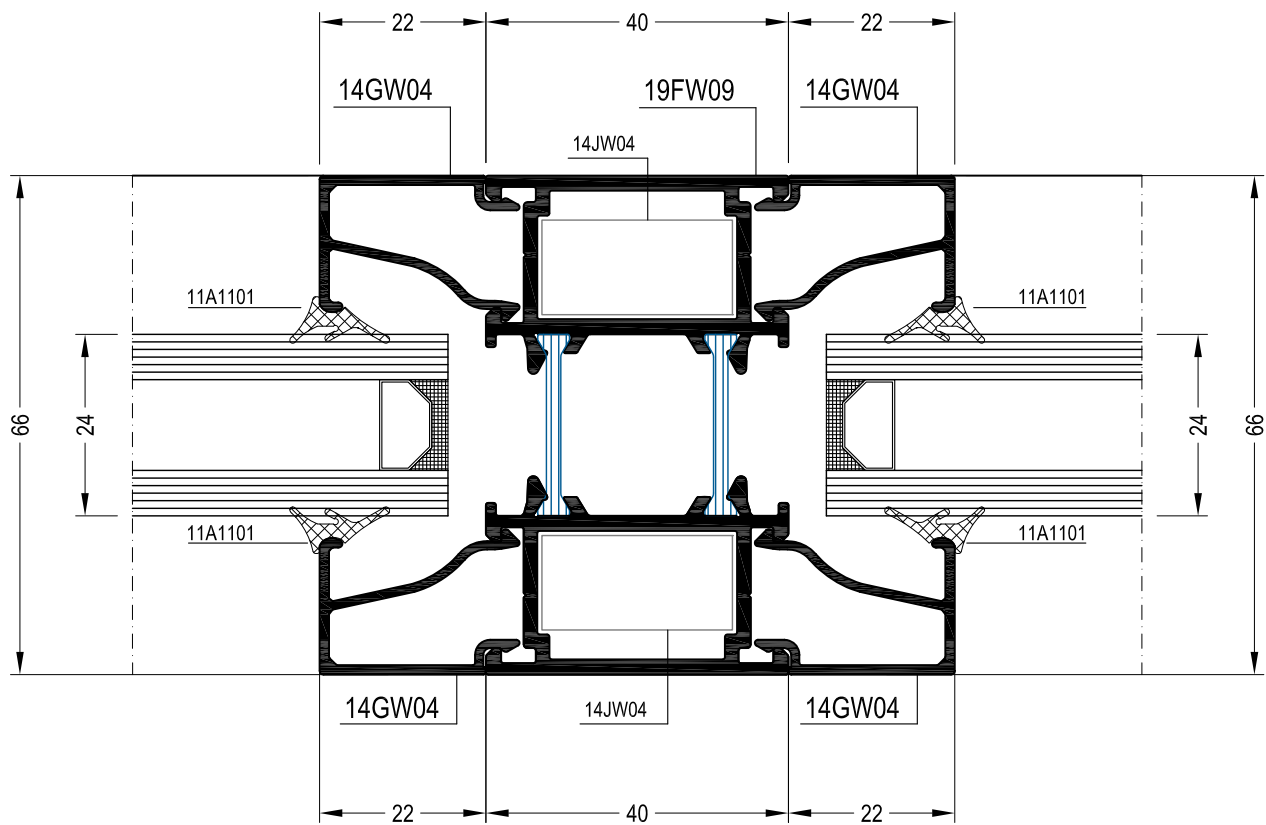
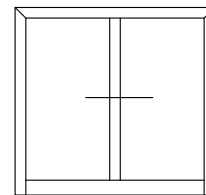

TURNING WINDOW

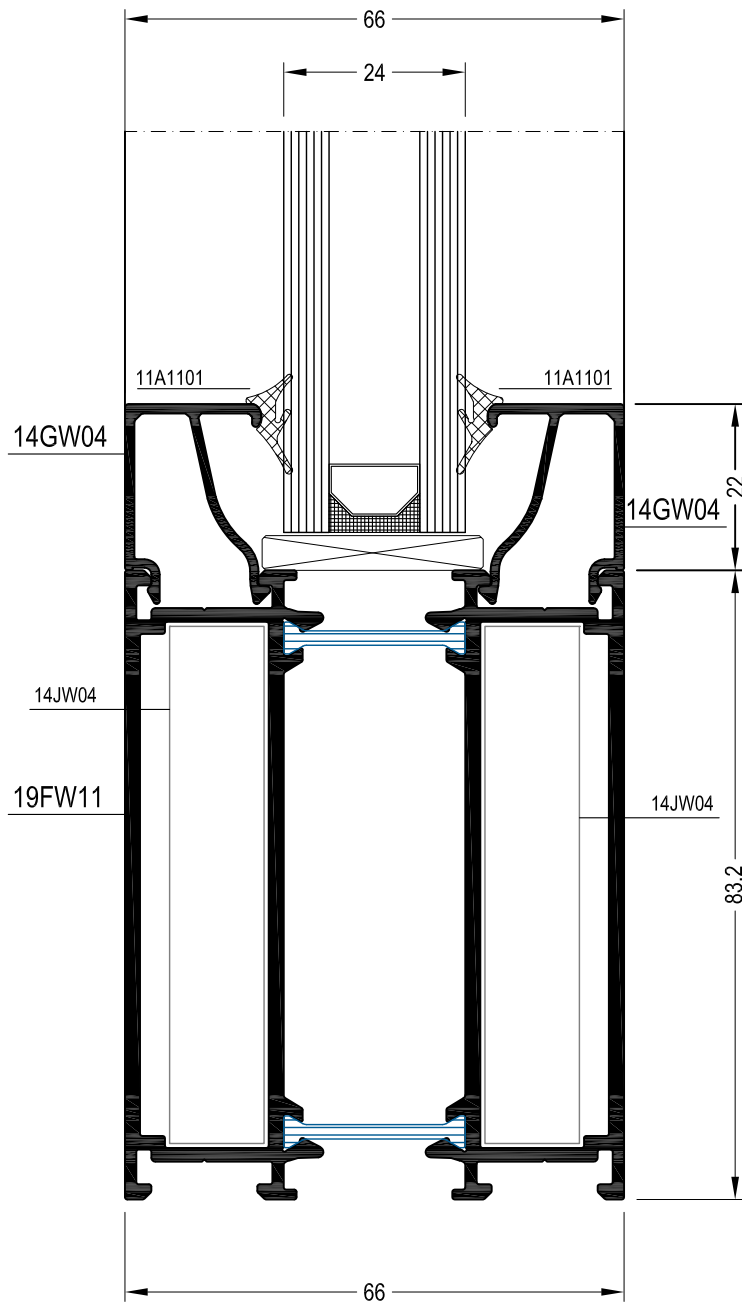
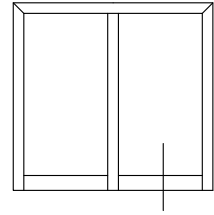

TURNING WINDOW

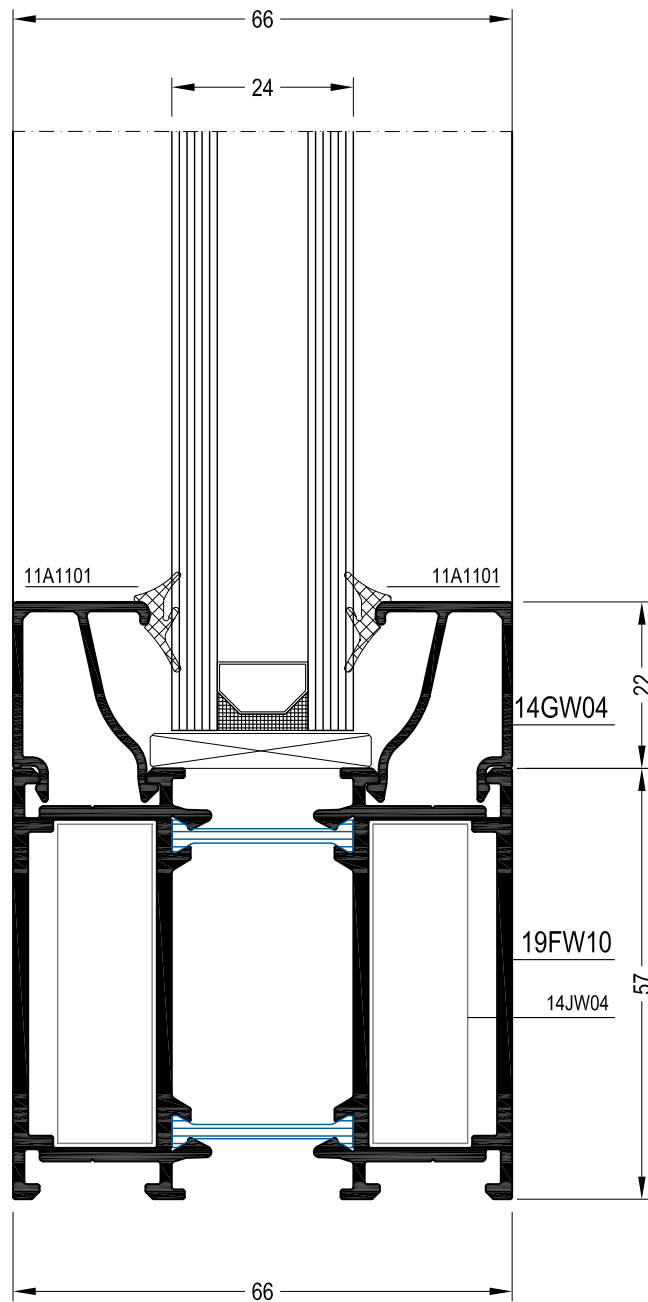
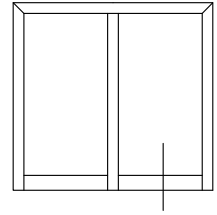

INSIDE OPENING DOOR

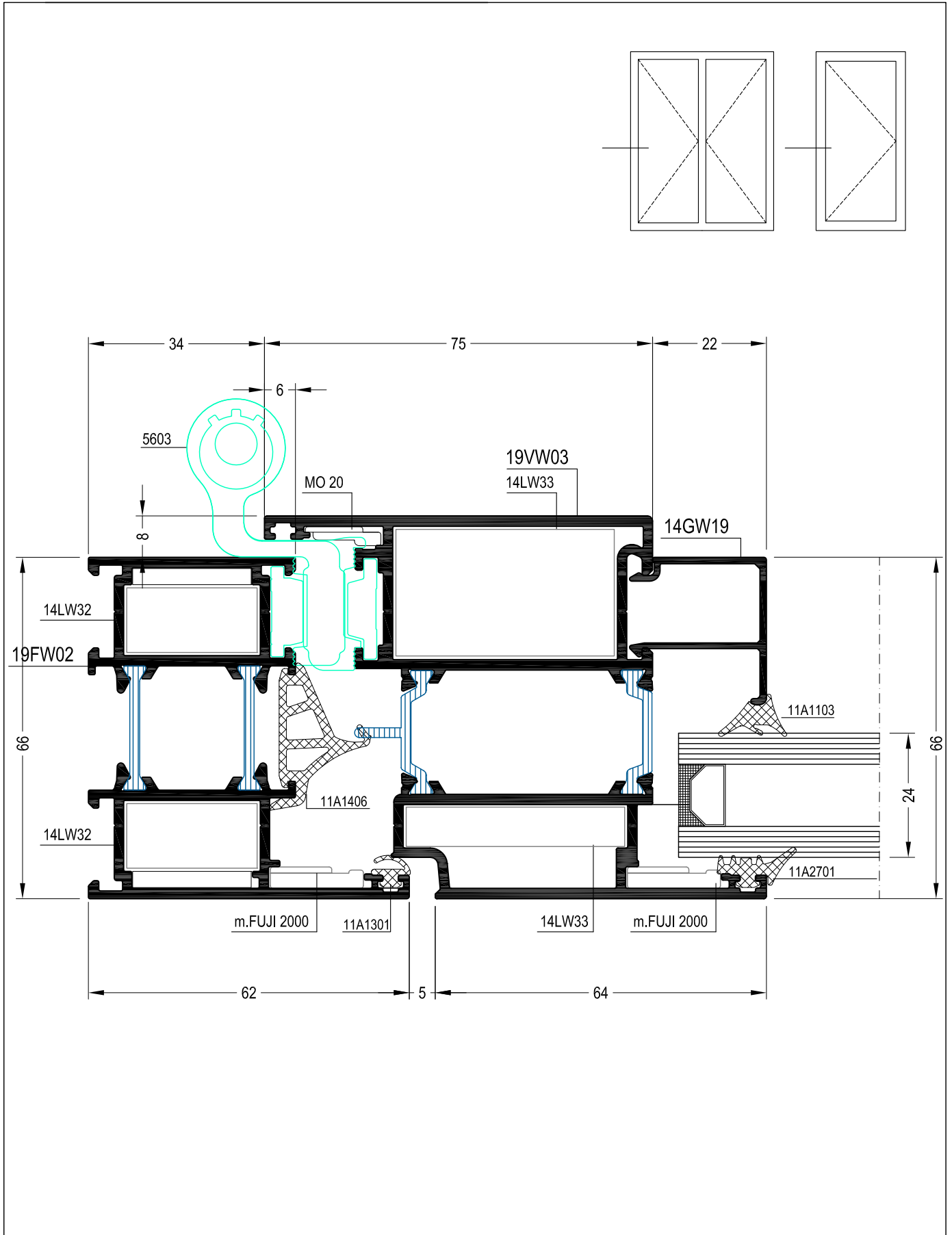

INSIDE OPENING DOOR

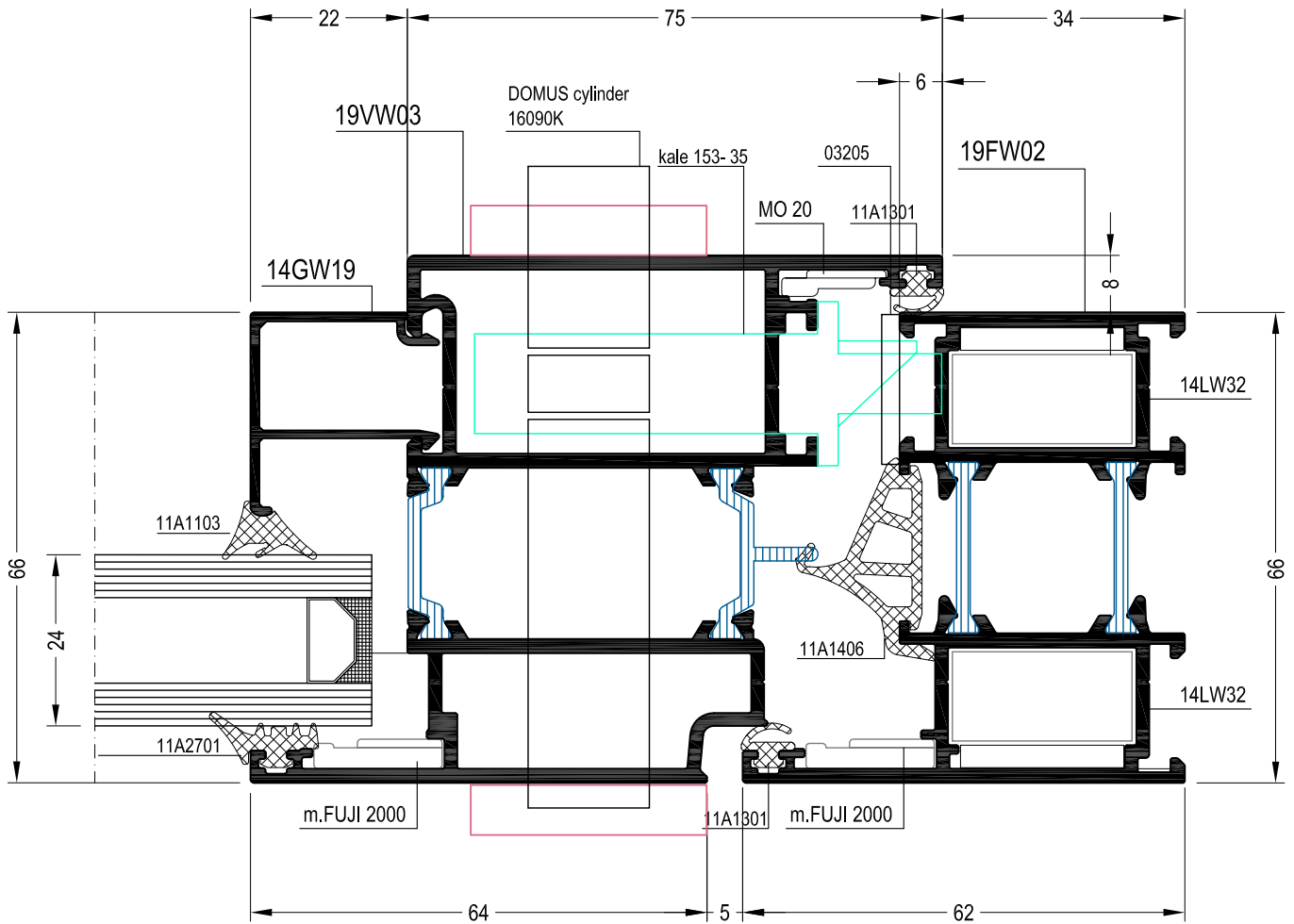
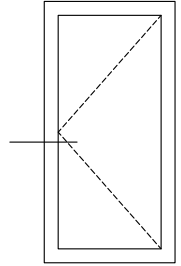

INSIDE OPENING DOOR

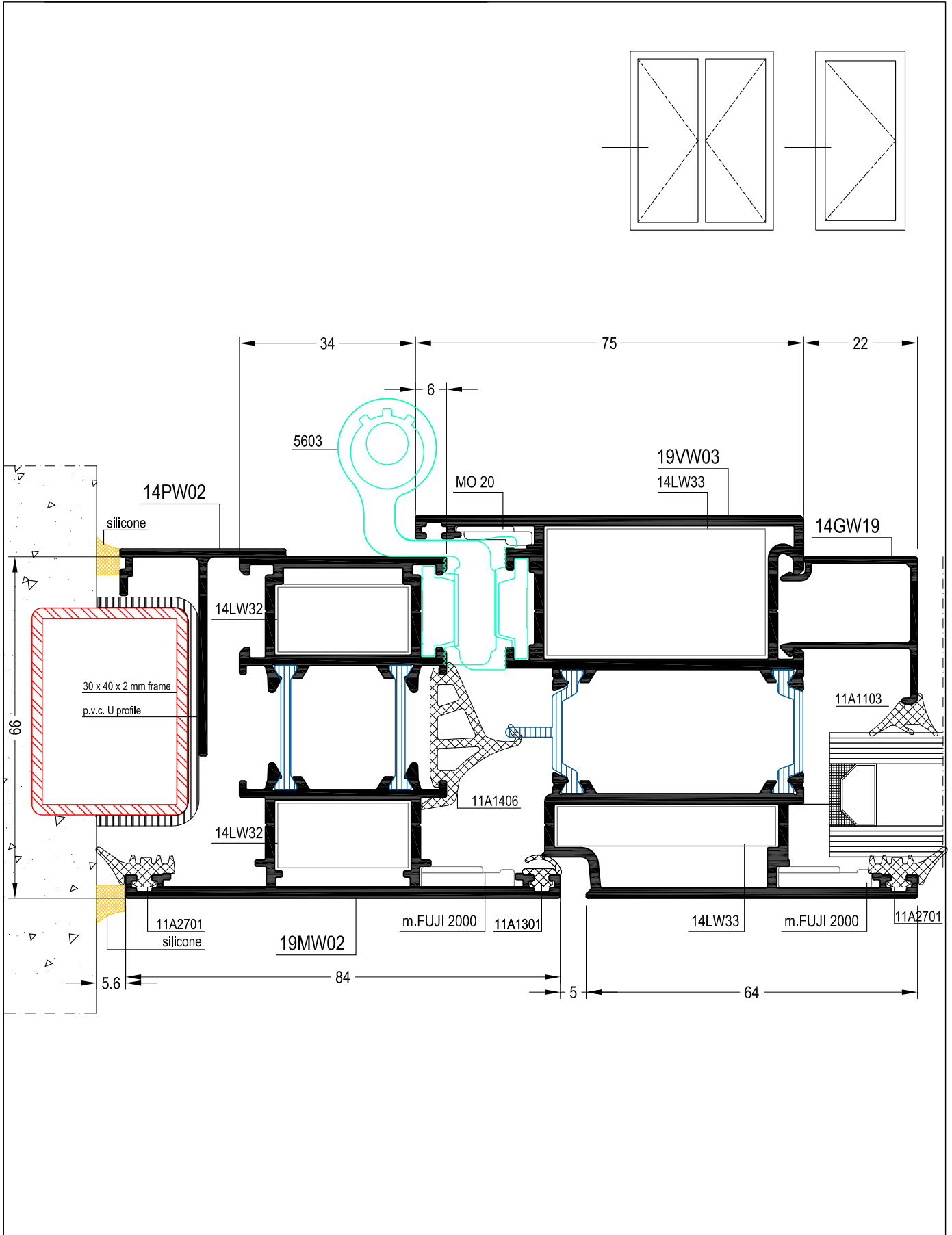

INSIDE OPENING DOOR

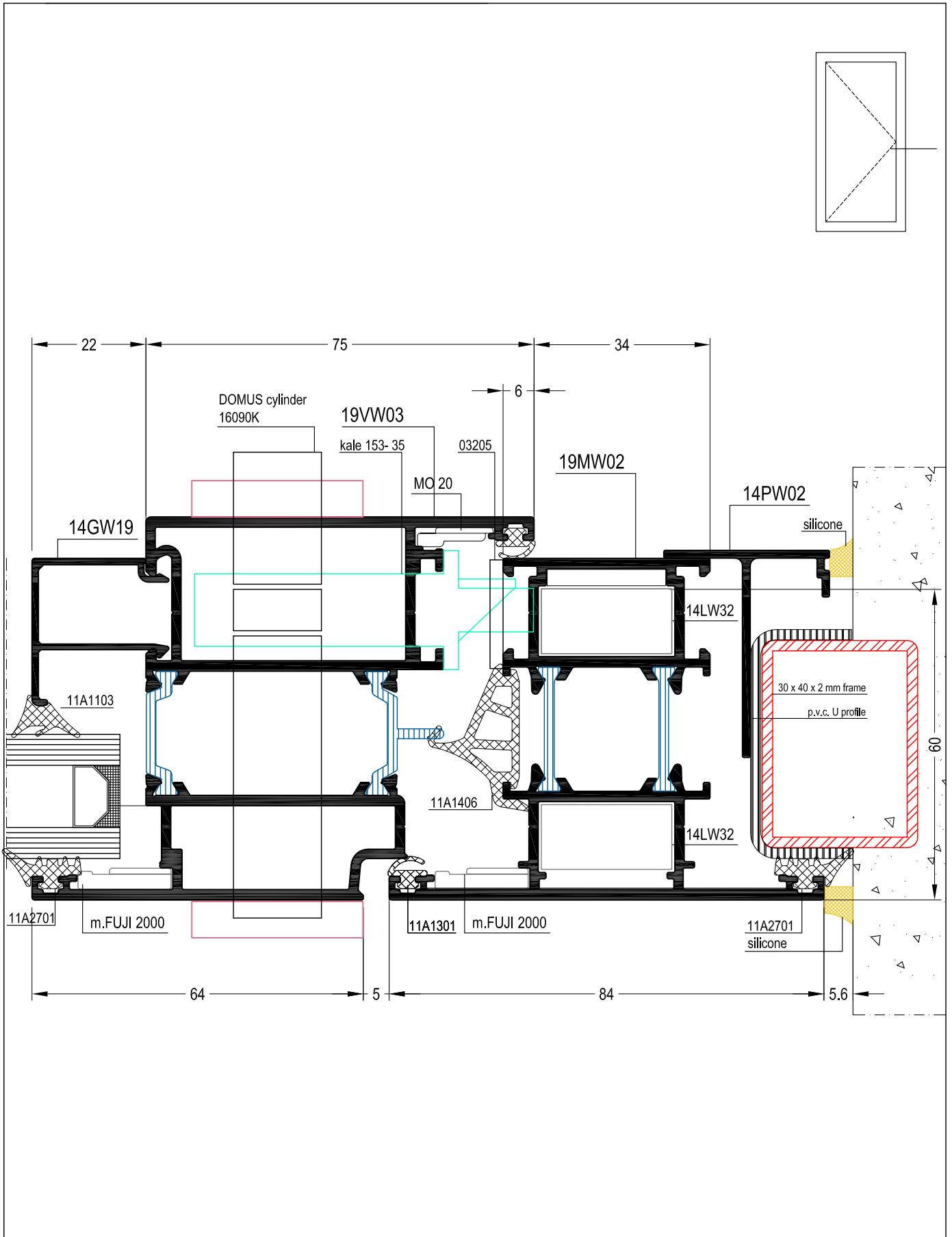

INSIDE OPENING DOOR

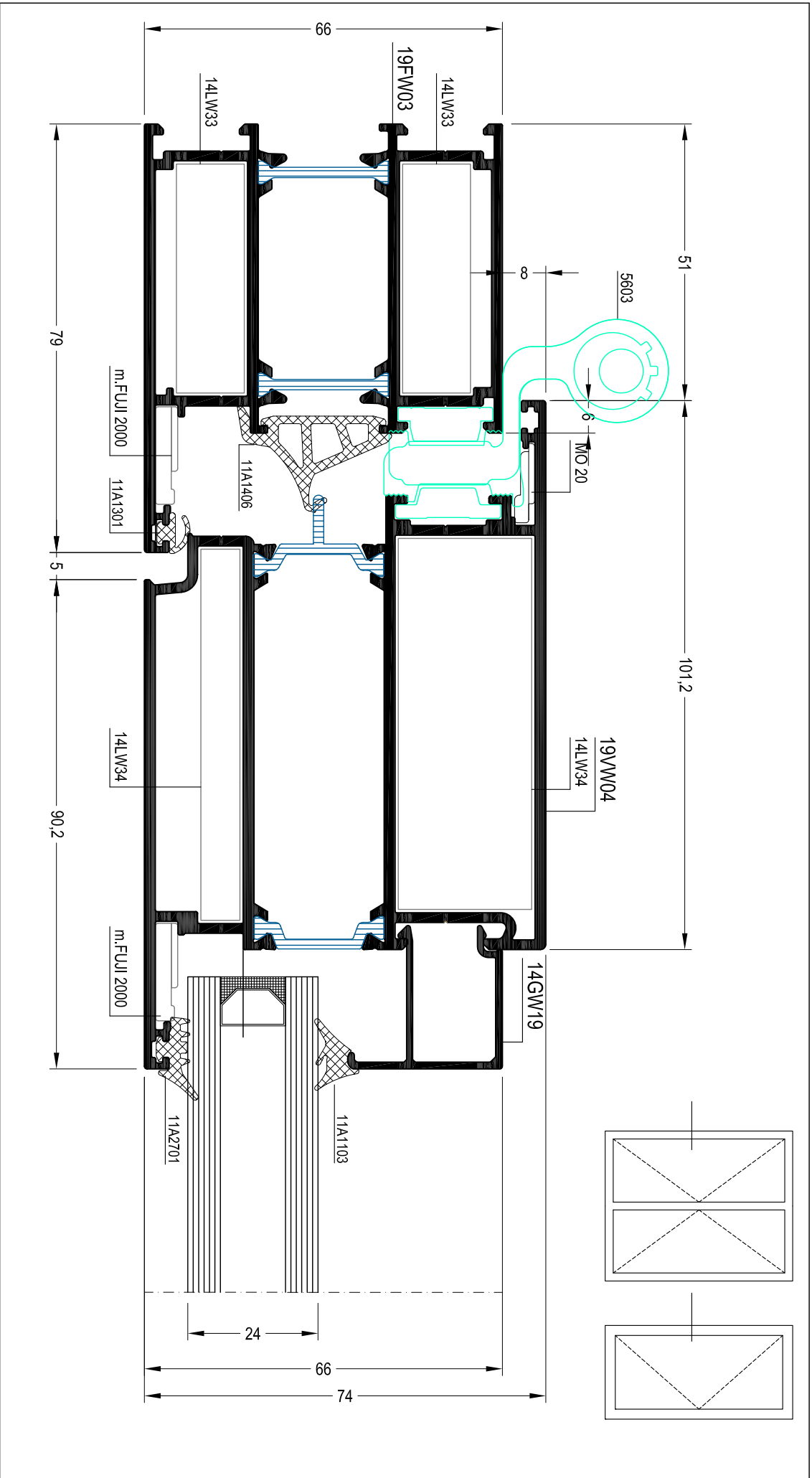

INSIDE OPENING DOOR

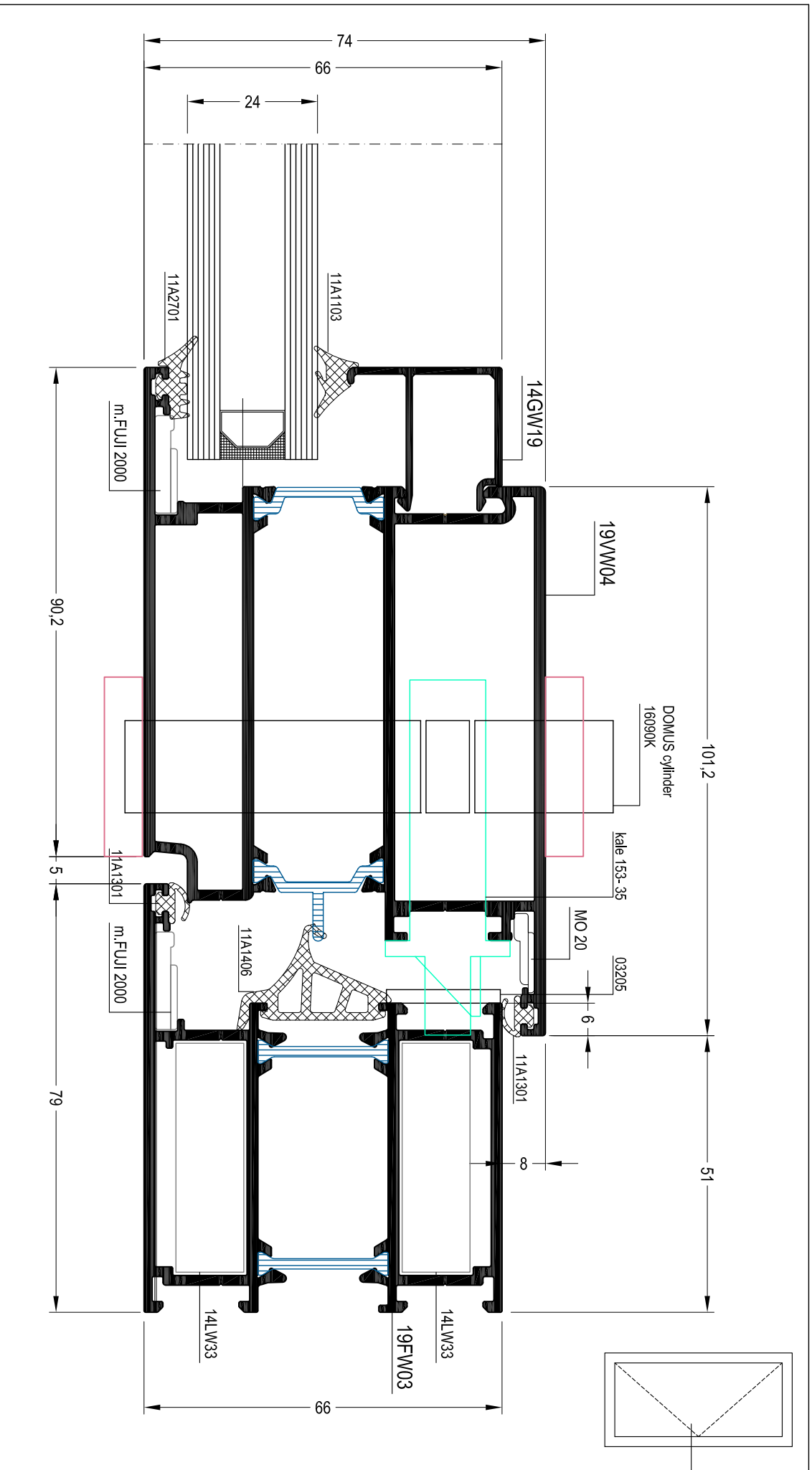

INSIDE OPENING DOOR

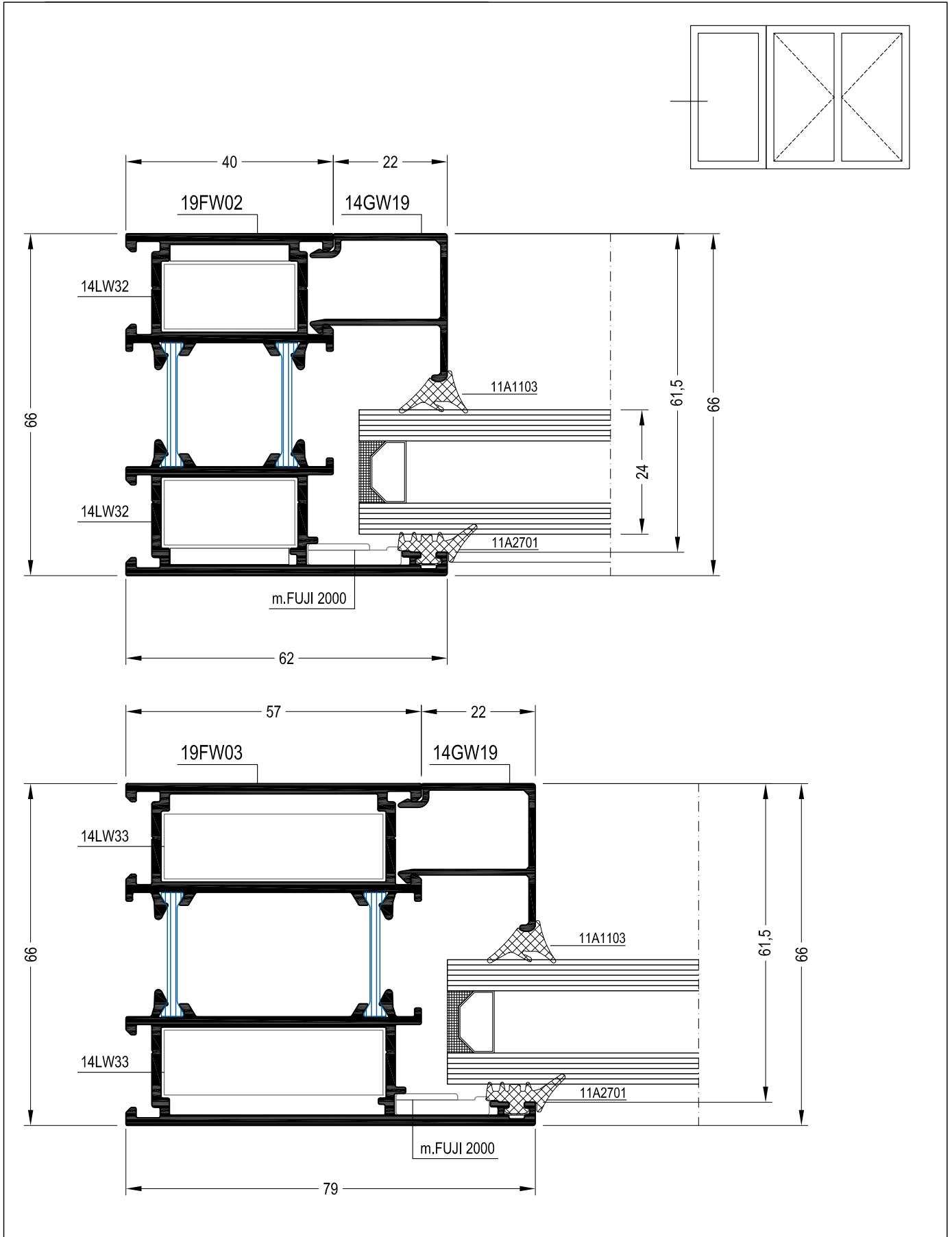

INSIDE OPENING DOOR

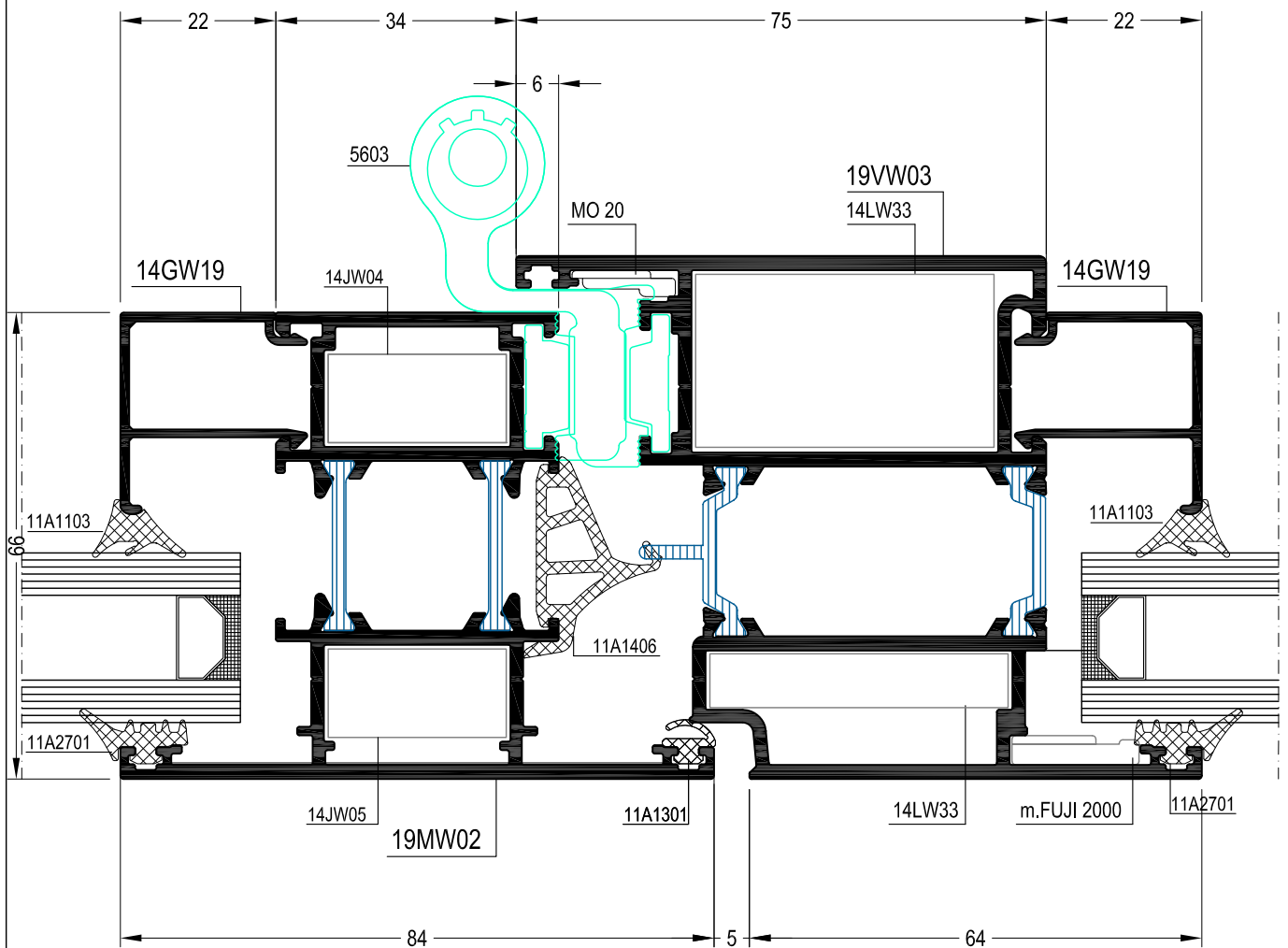
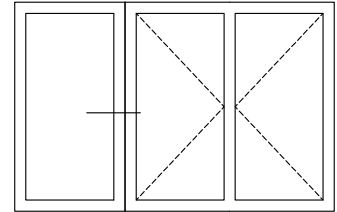

INSIDE OPENING DOOR

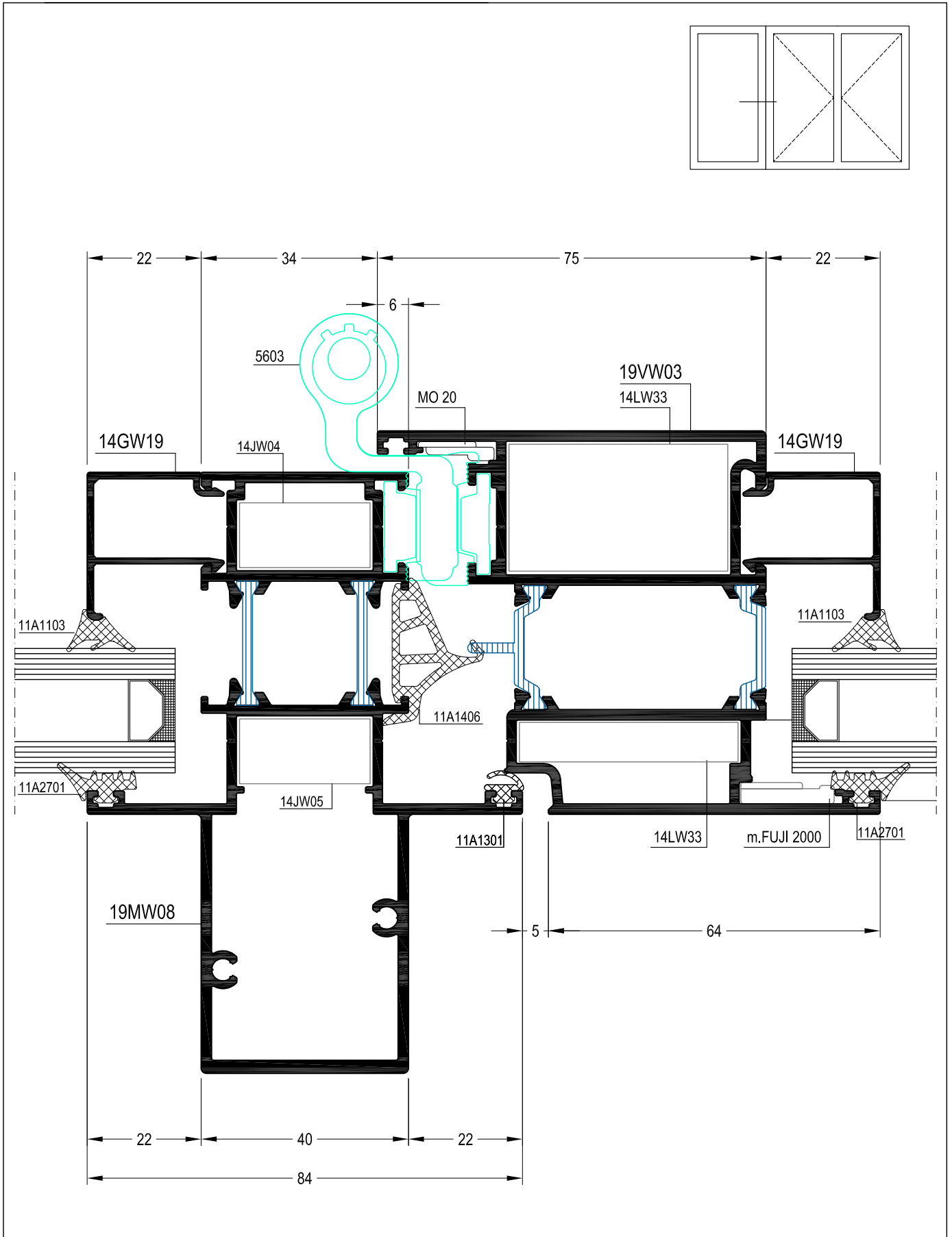

INSIDE OPENING DOOR

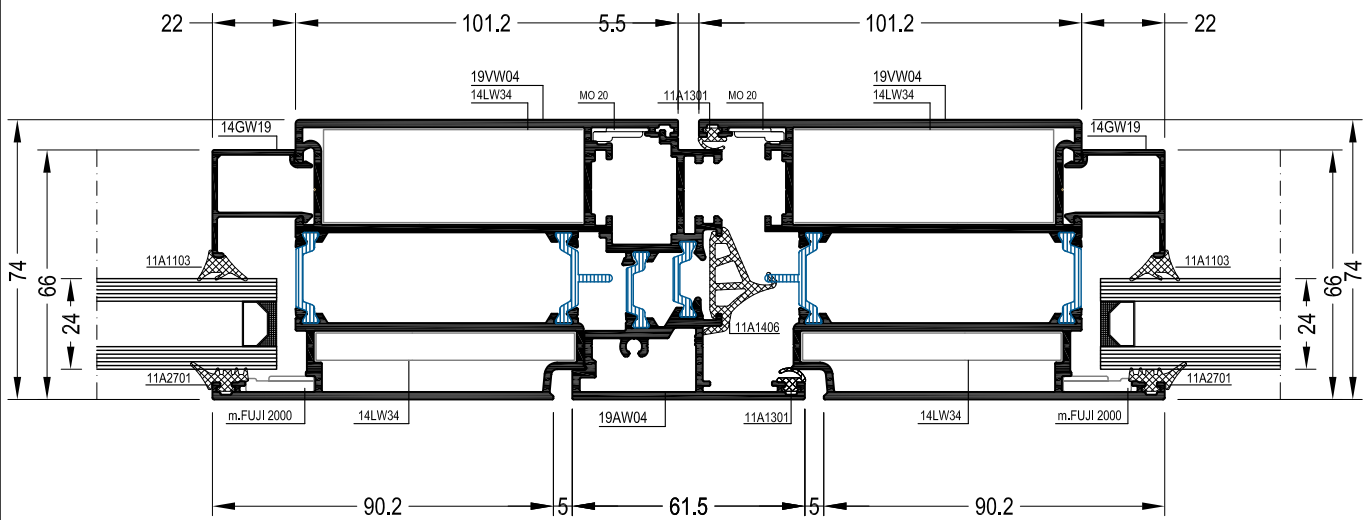
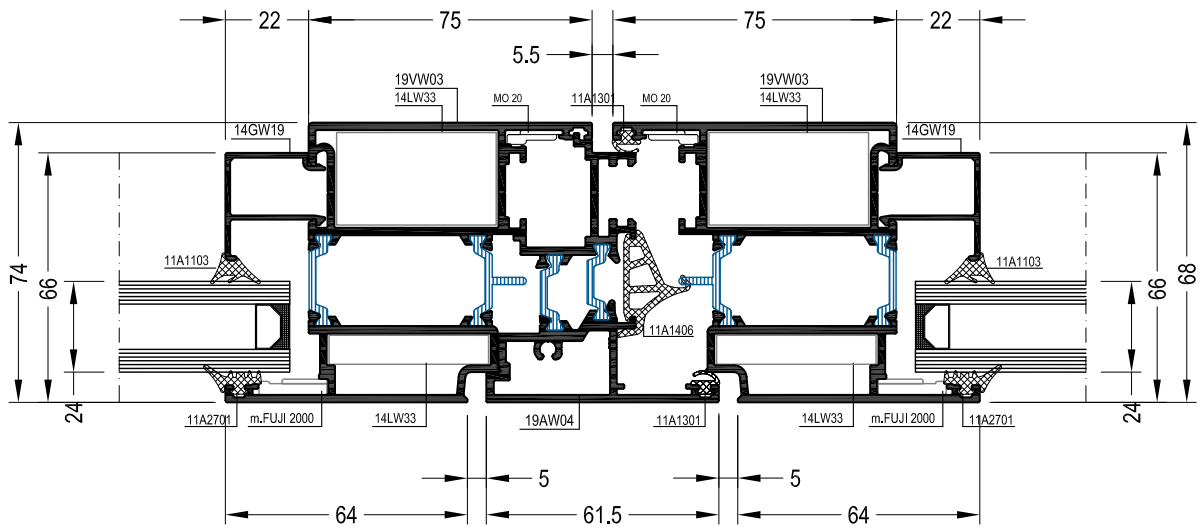
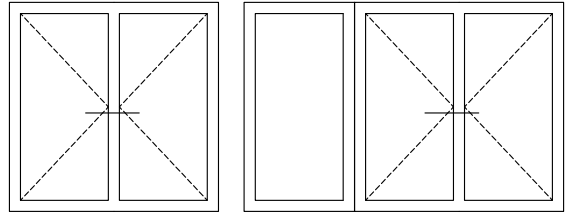

SYSTEM CASTLE 1966 W+

DETAILS

INSIDE OPENING DOOR

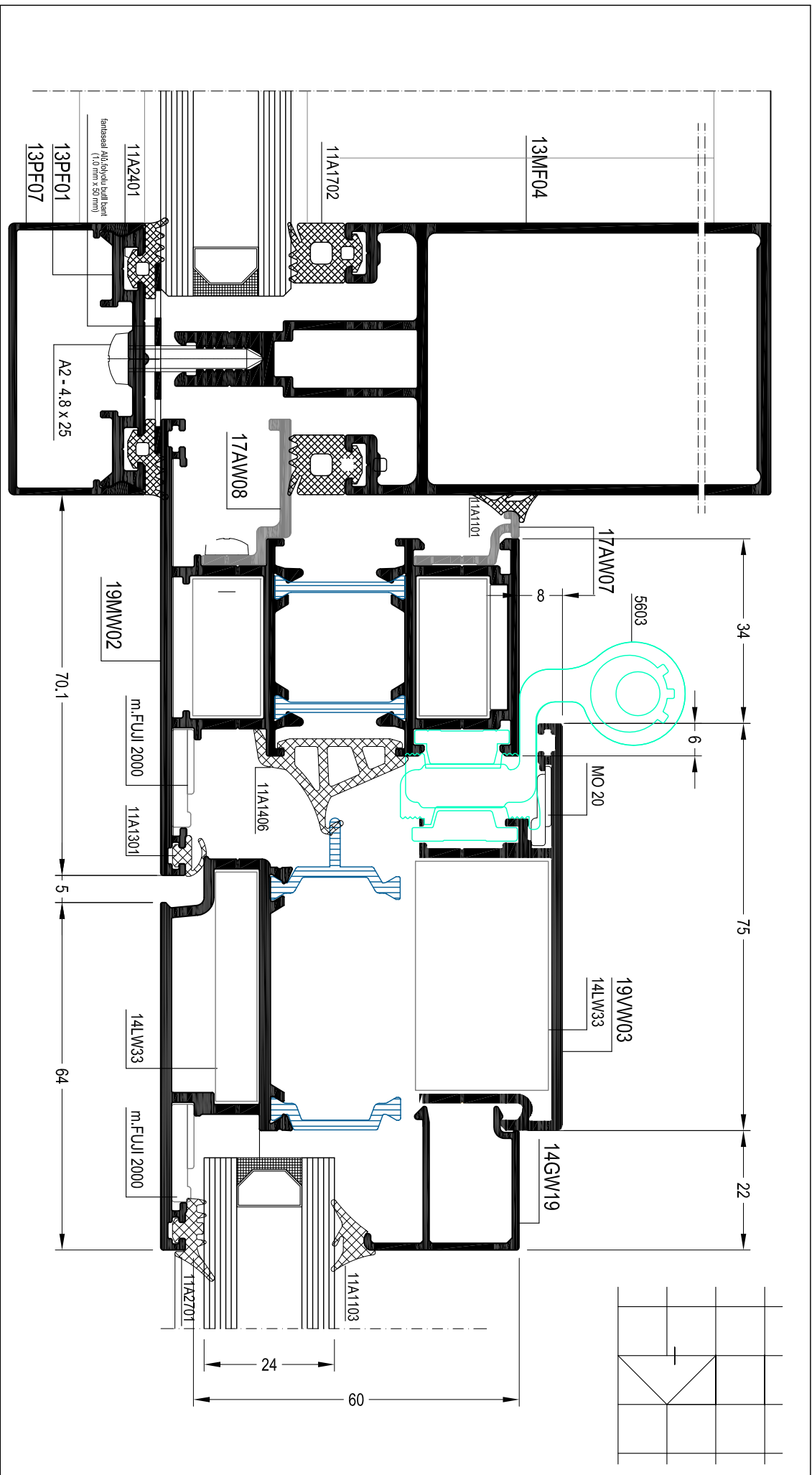

INSIDE OPENING DOOR

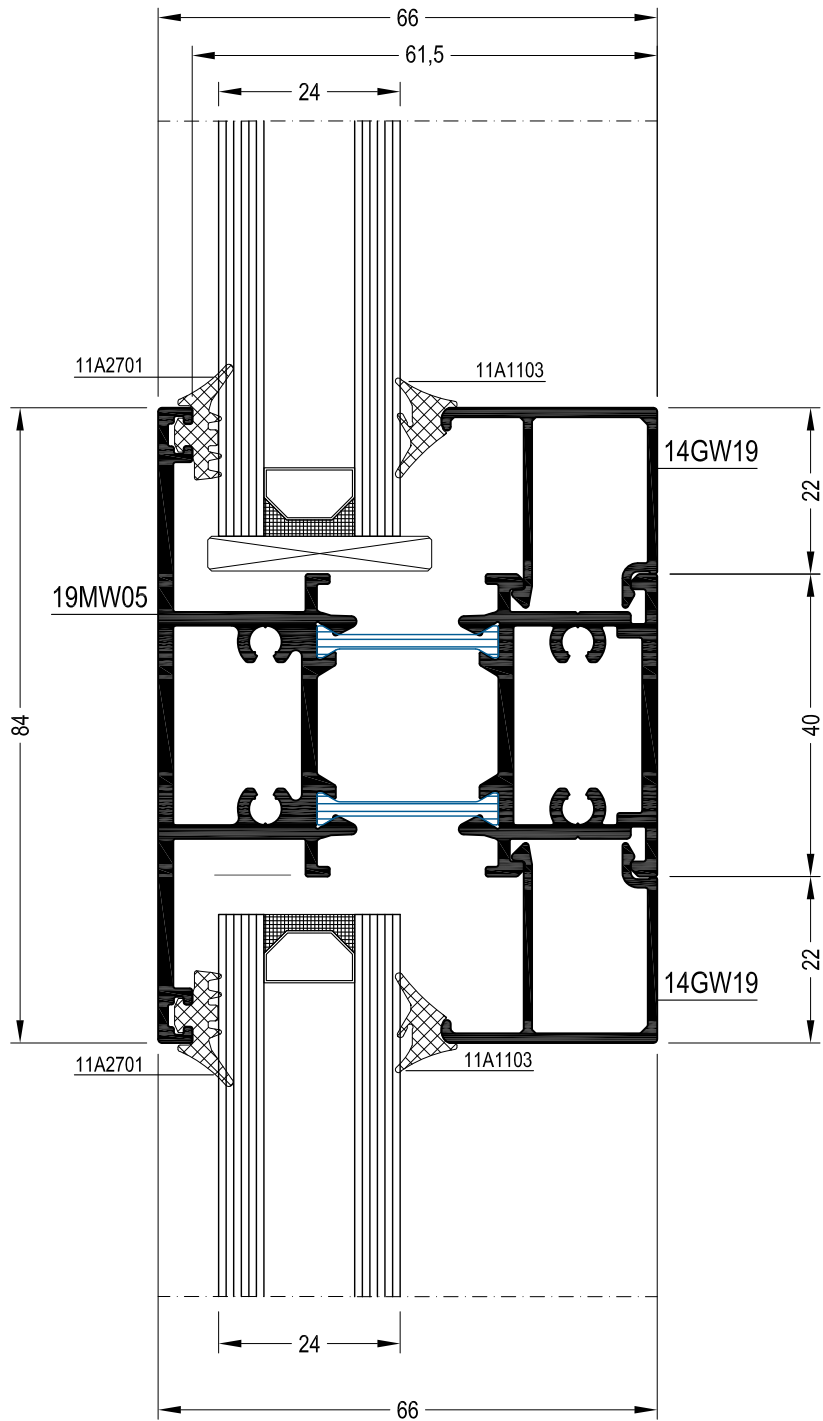
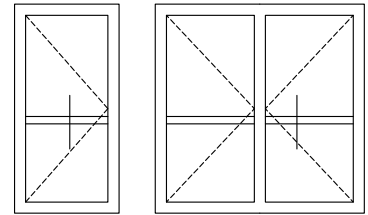

INSIDE OPENING DOOR

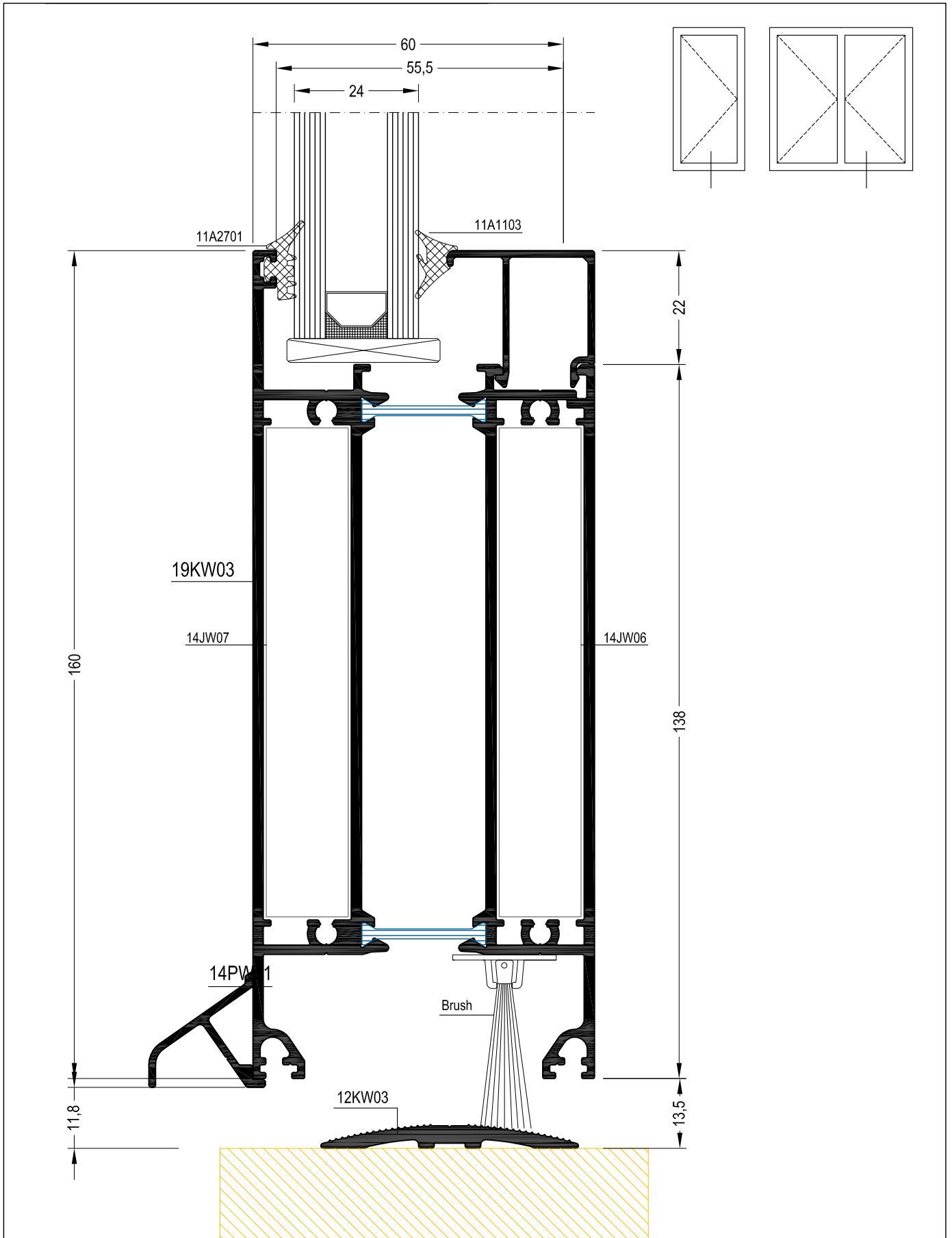

INSIDE OPENING DOOR

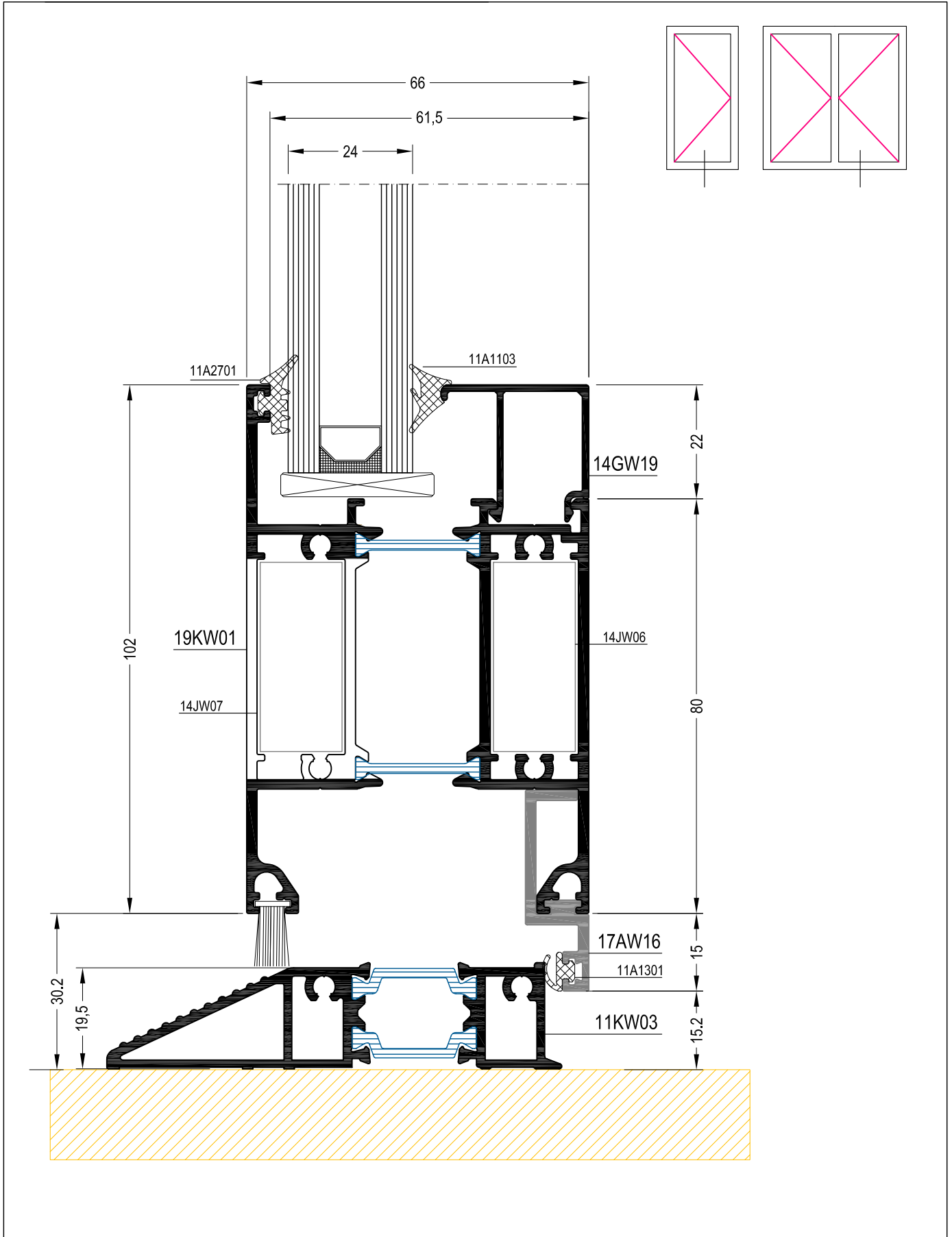

INSIDE OPENING DOOR

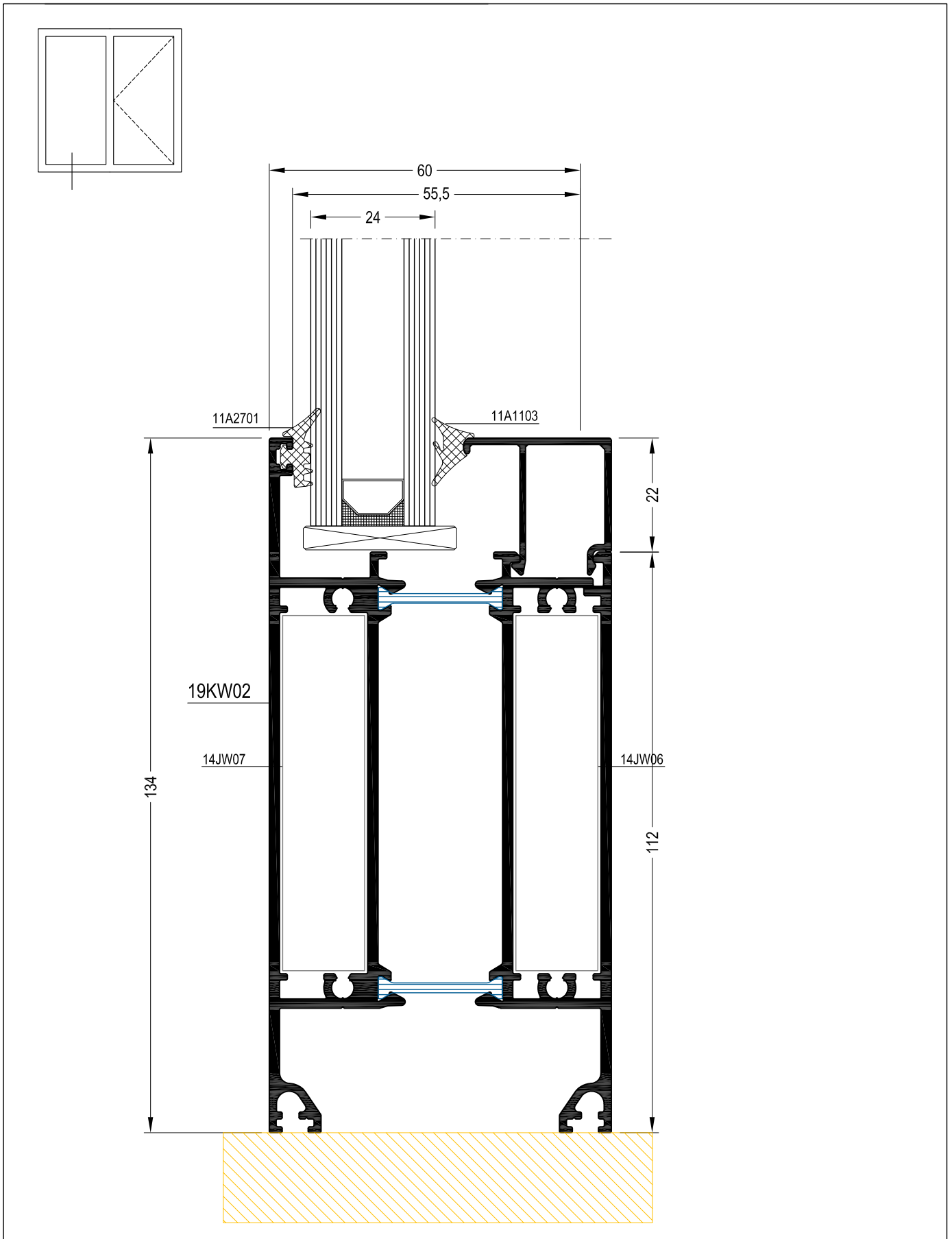

OUTSIDE OPENING DOOR

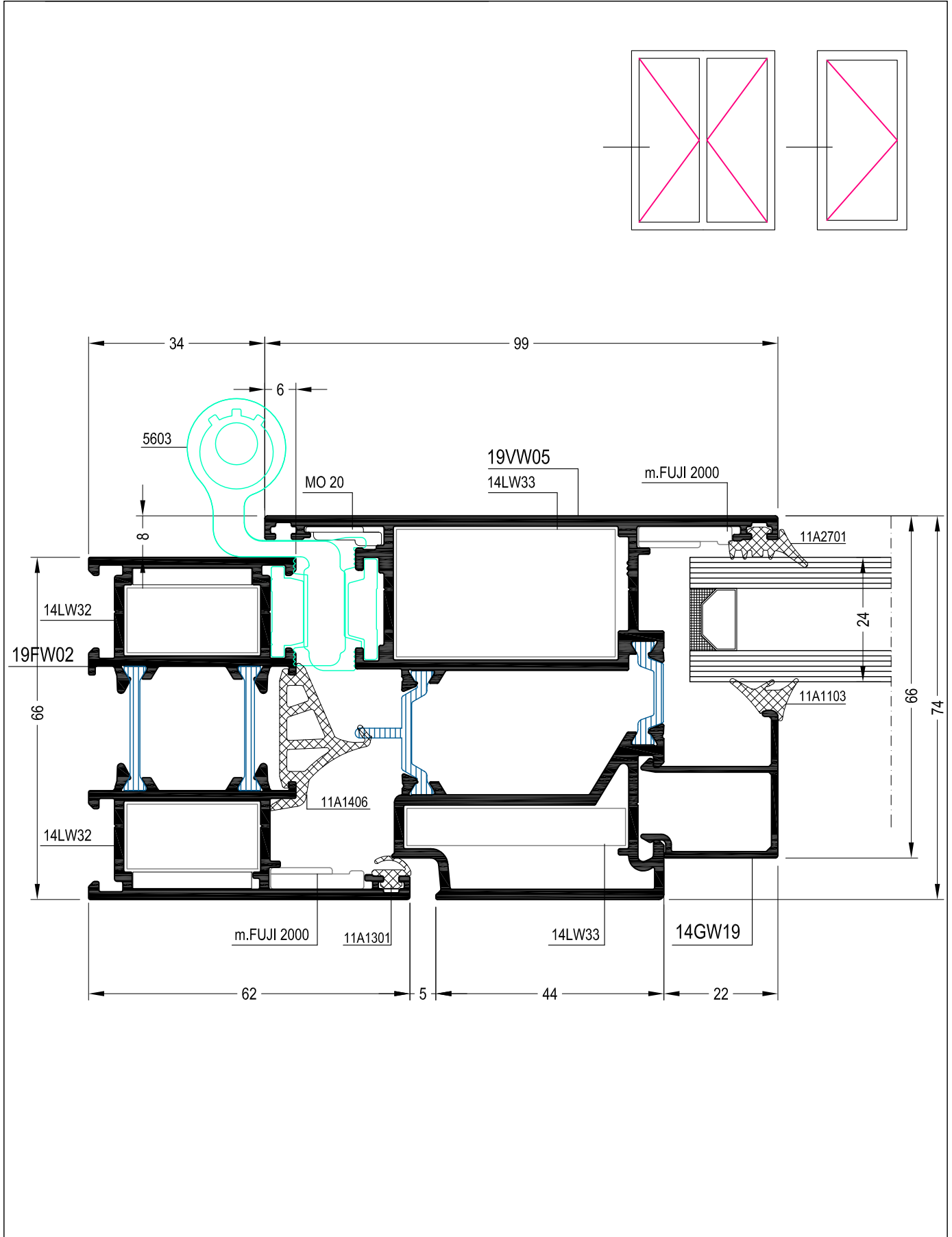

OUTSIDE OPENING DOOR

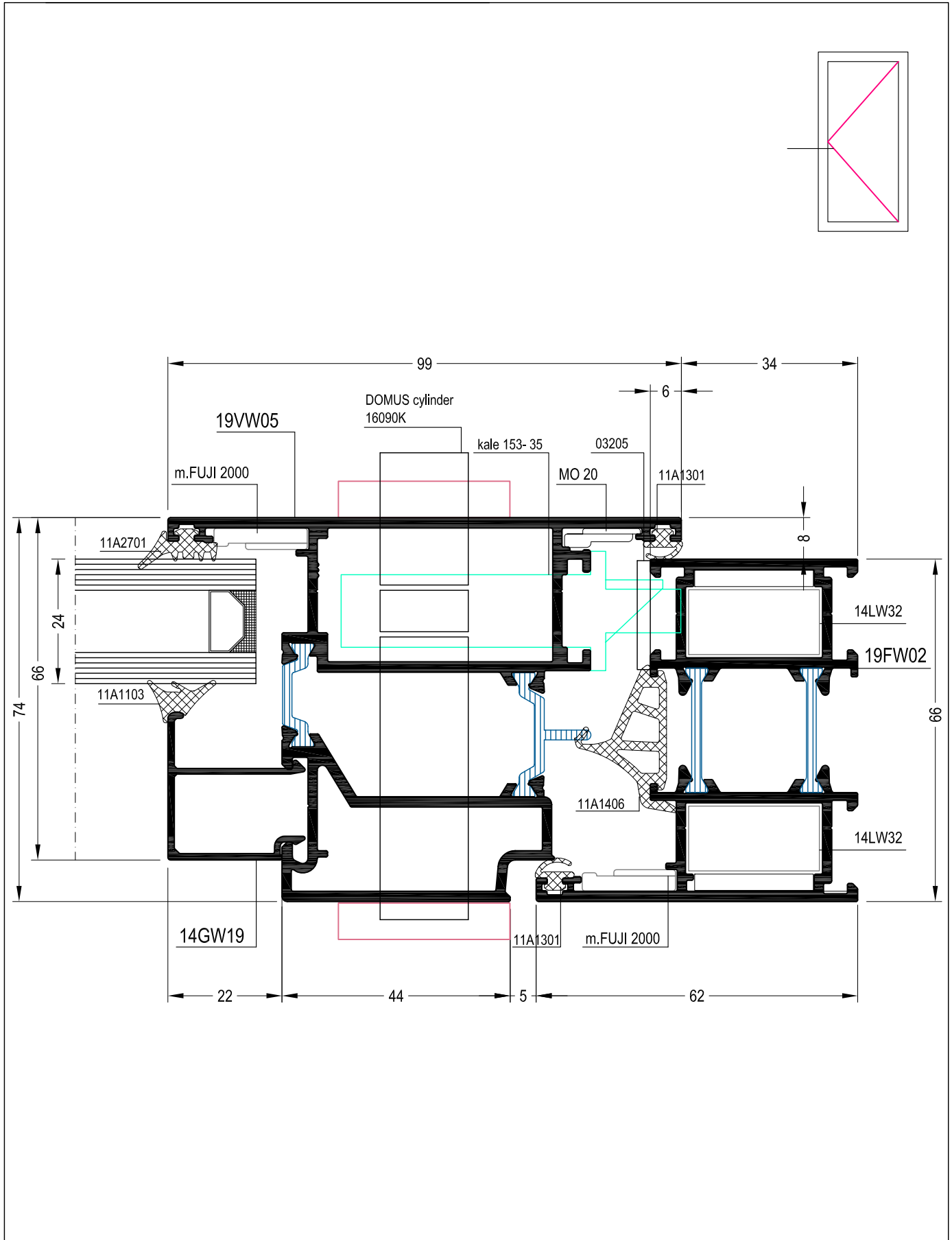

OUTSIDE OPENING DOOR

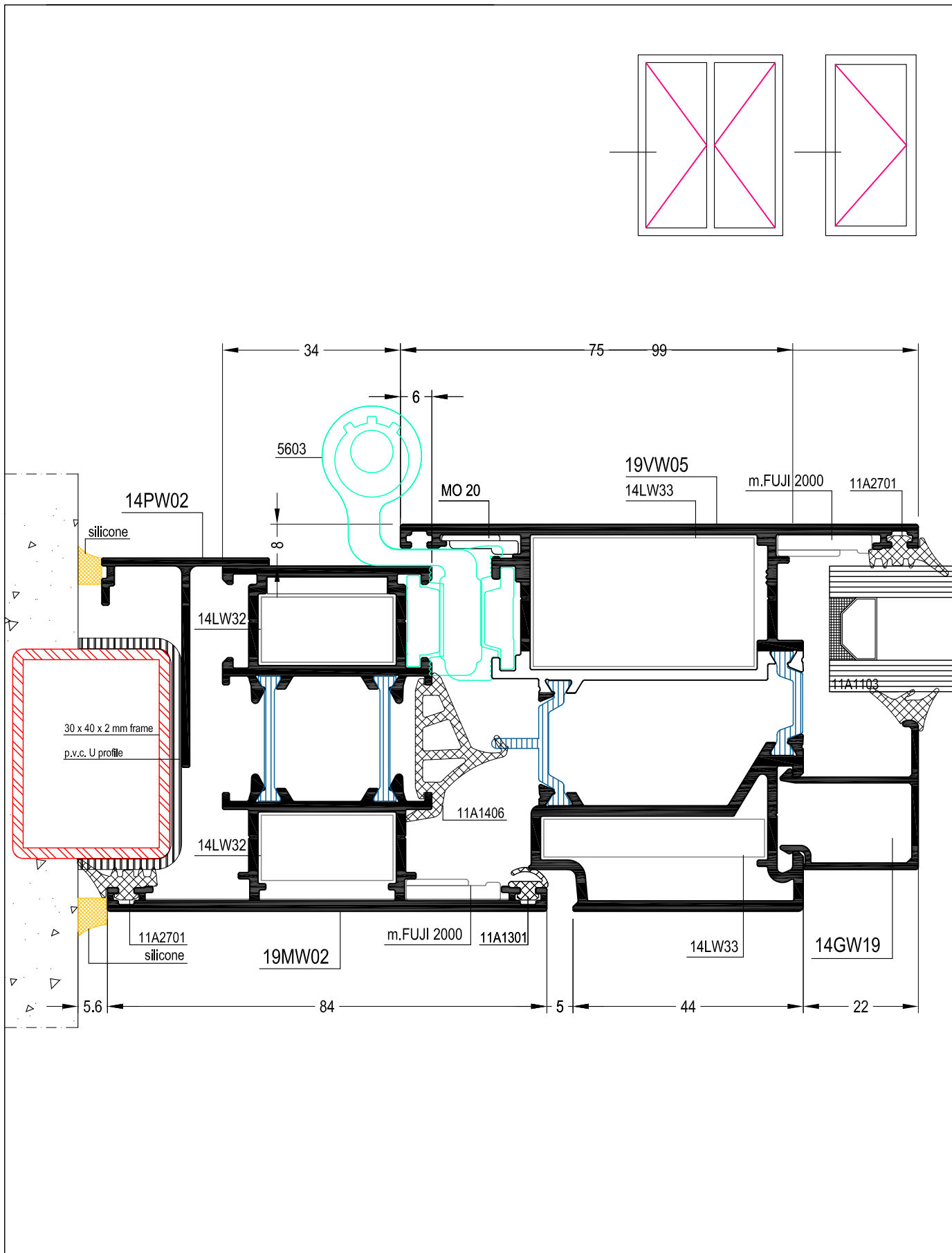

OUTSIDE OPENING DOOR

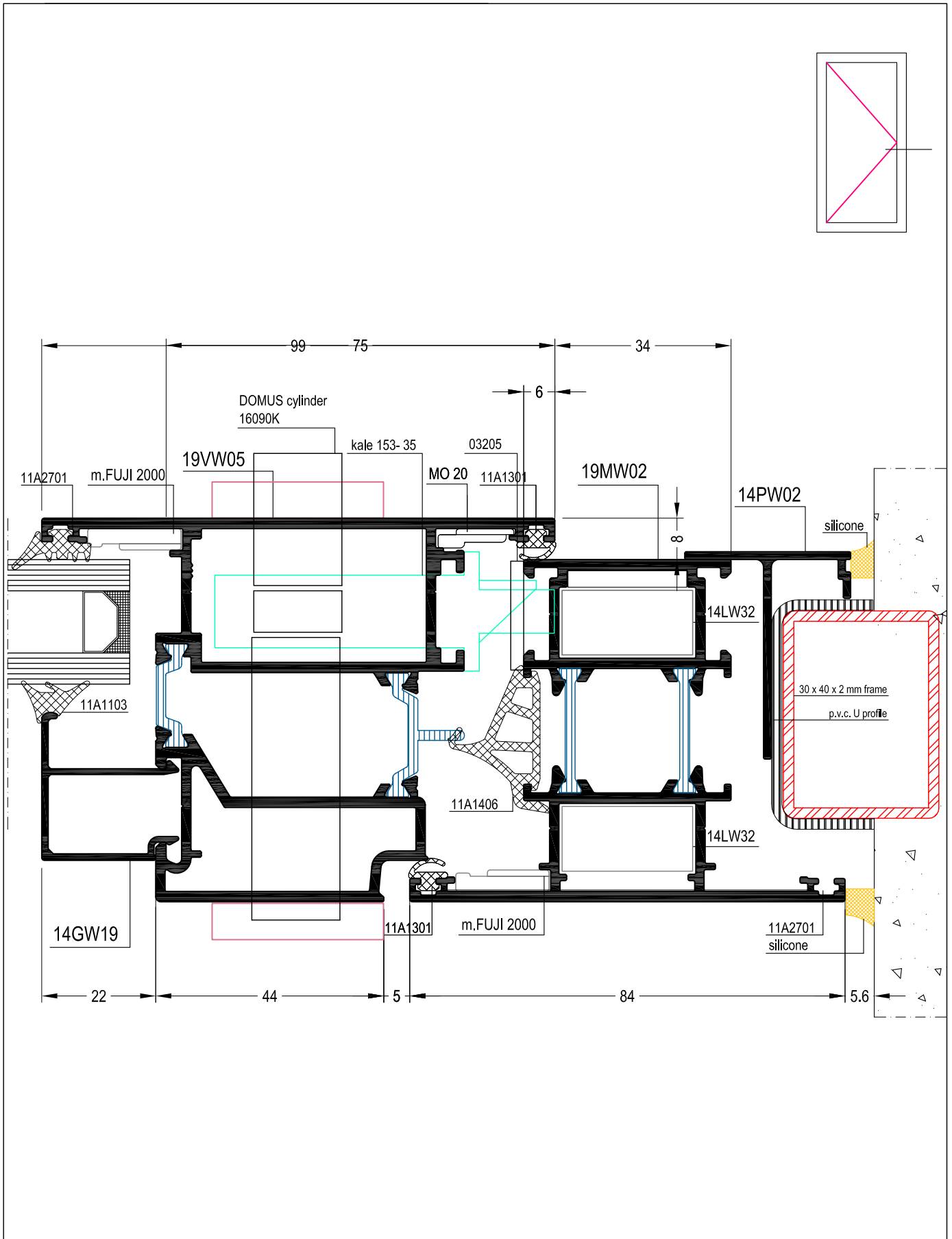

OUTSIDE OPENING DOOR

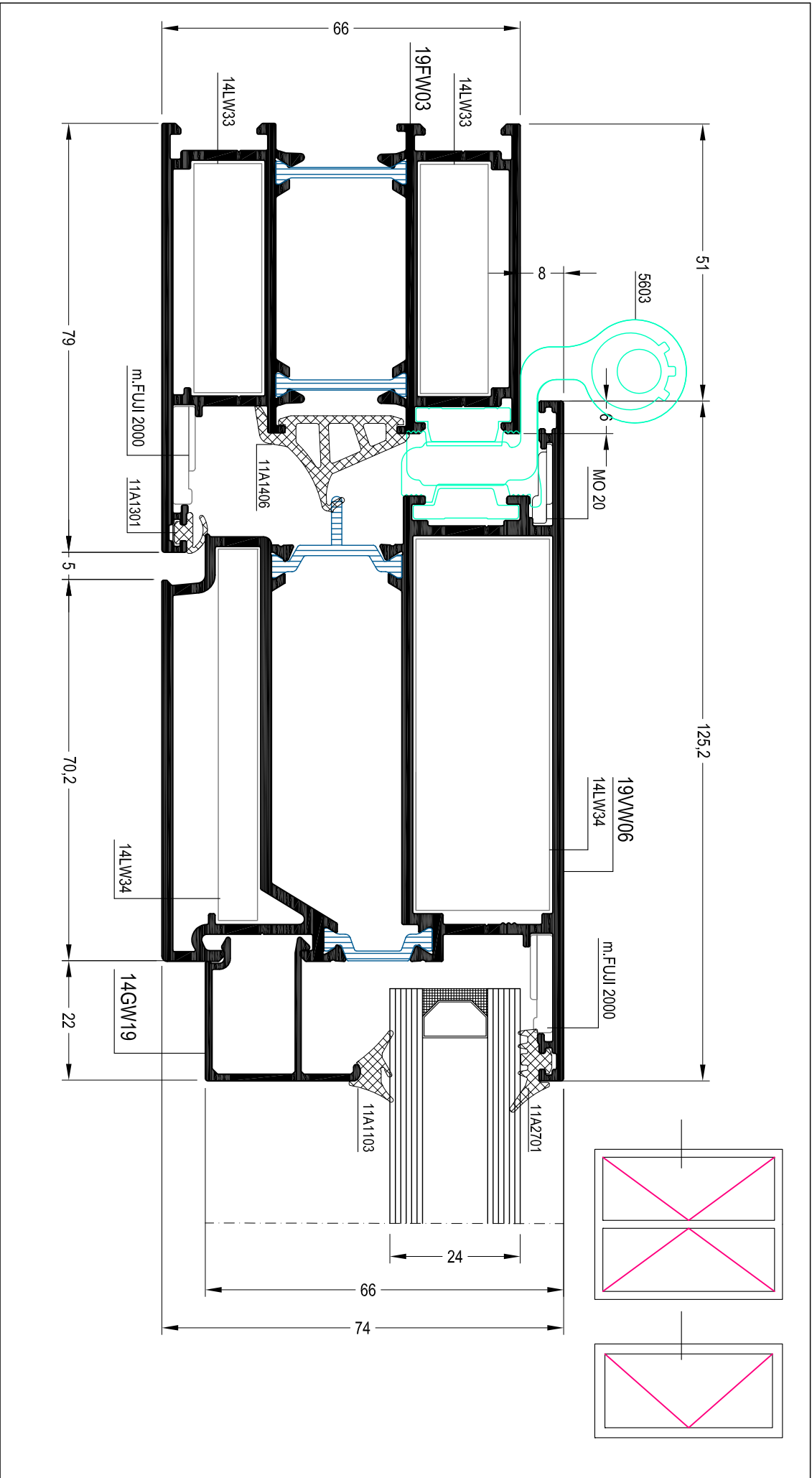

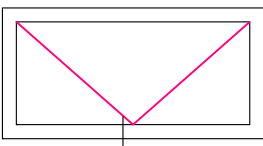
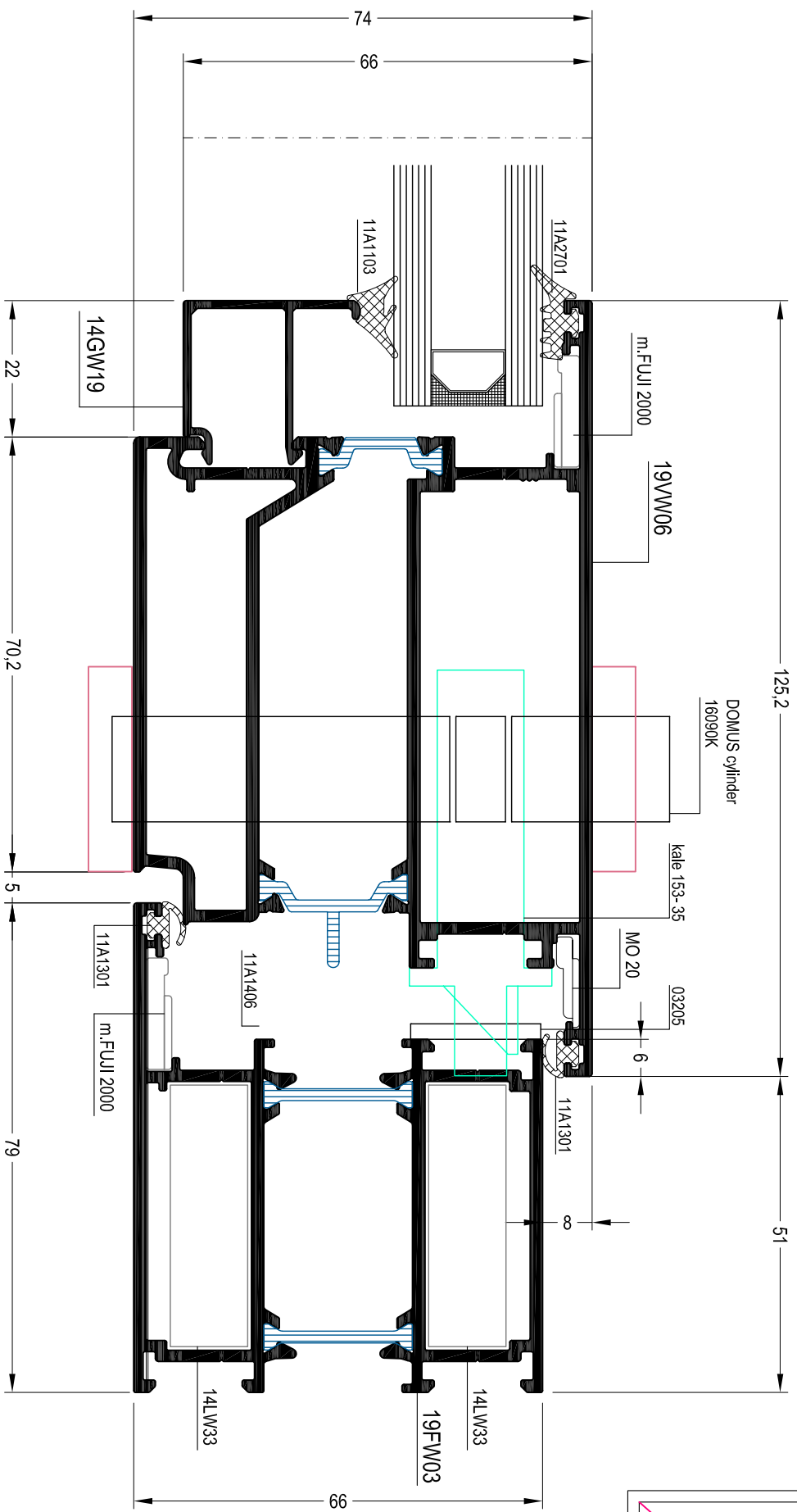

OUTSIDE OPENING DOOR

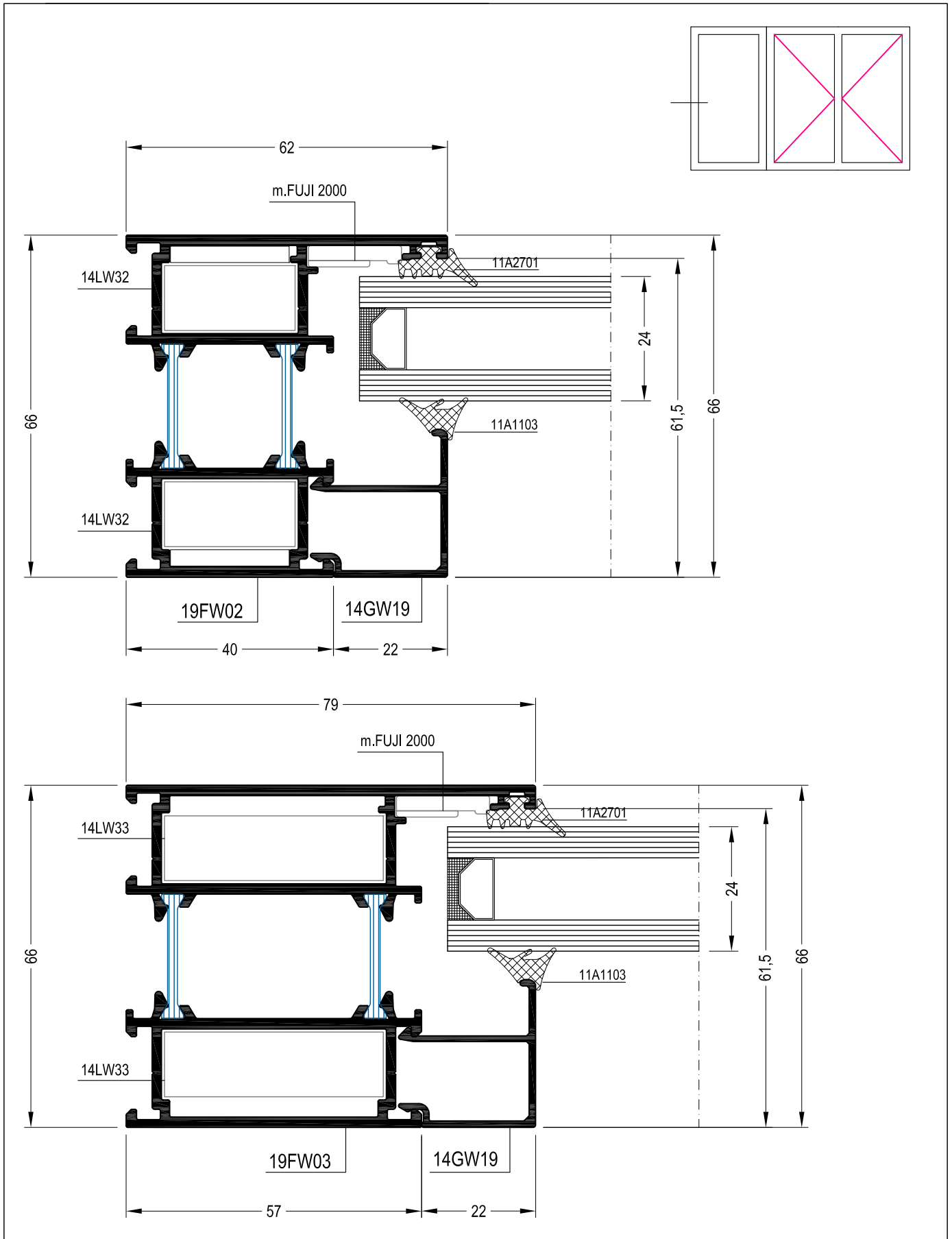

OUTSIDE OPENING DOOR

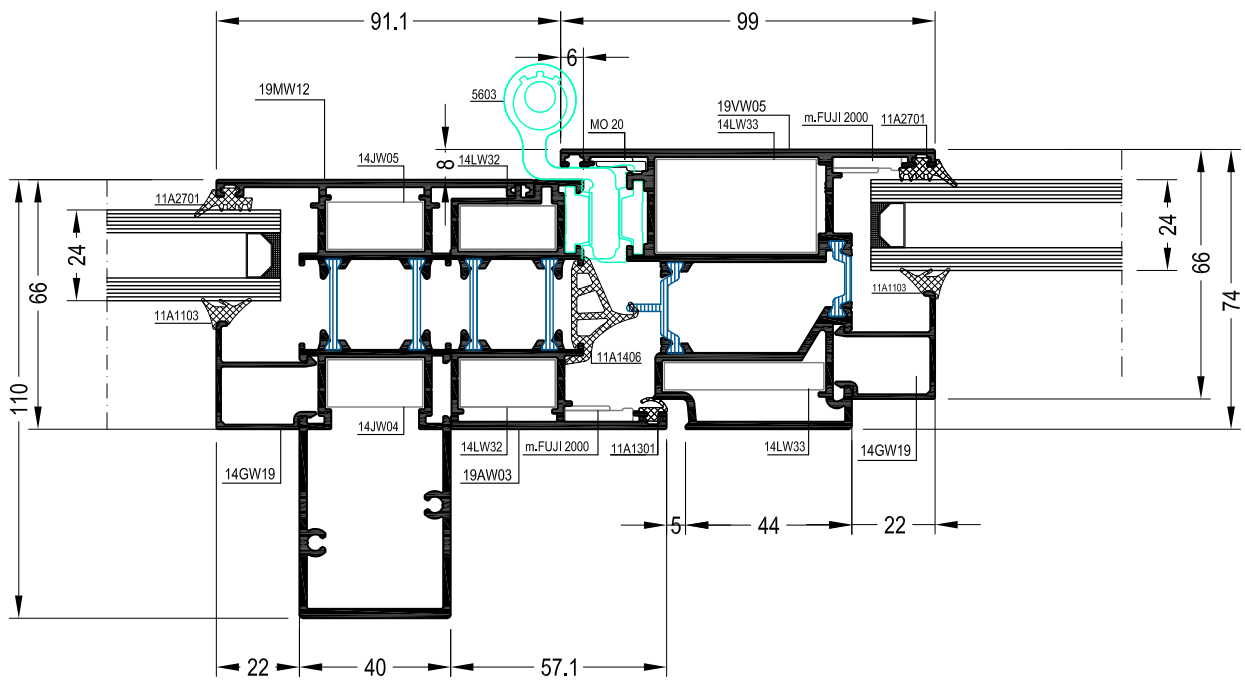
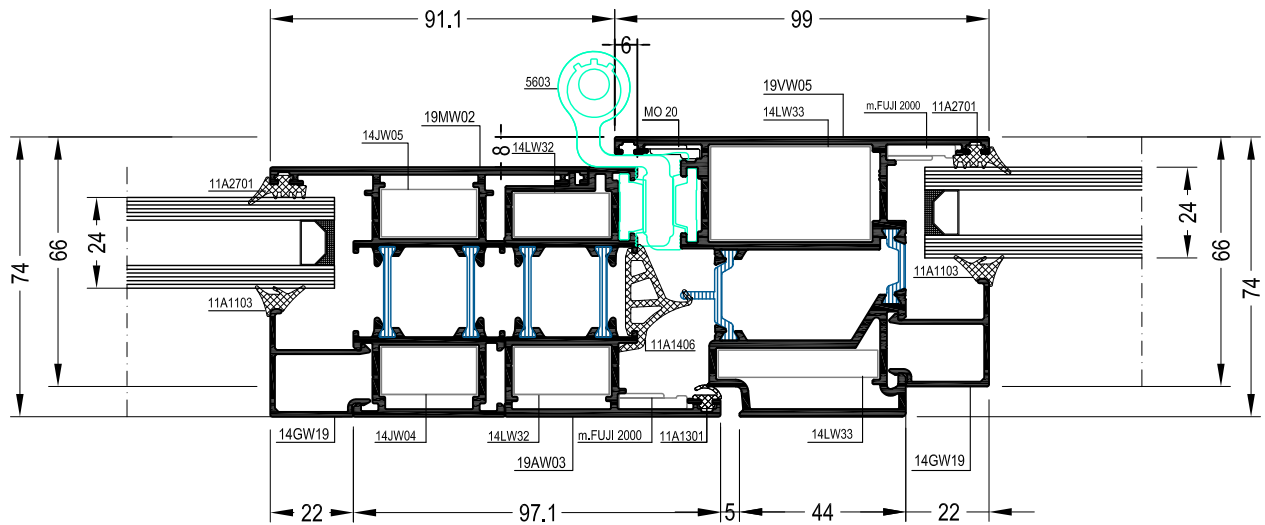
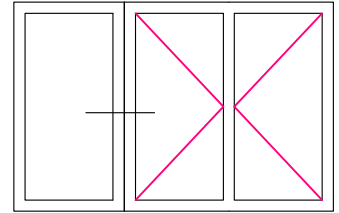

OUTSIDE OPENING DOOR

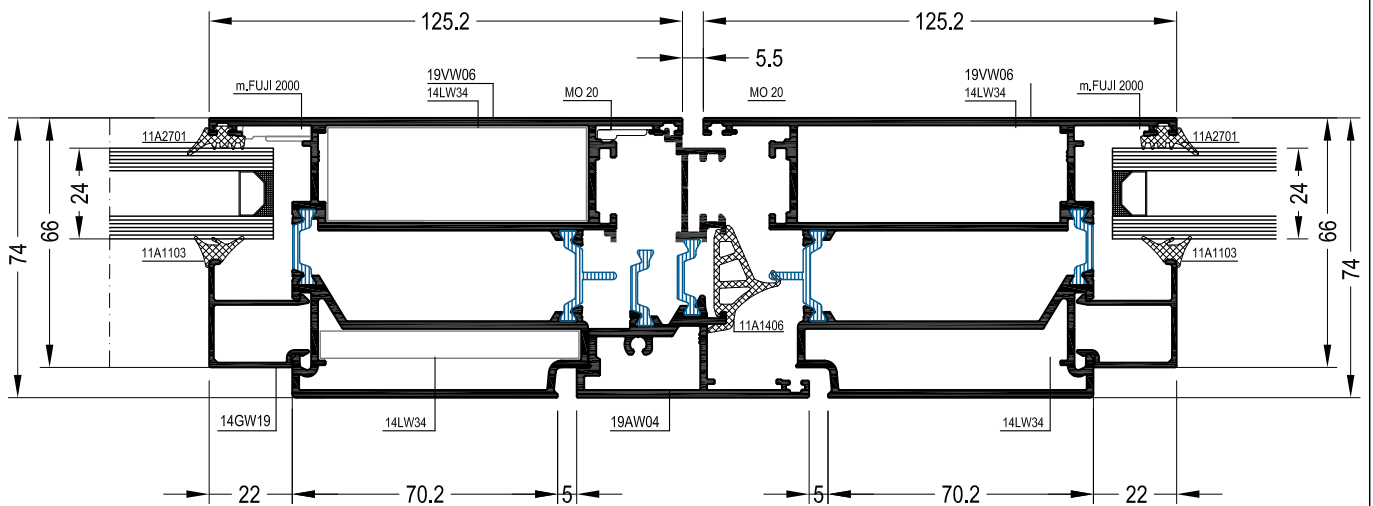
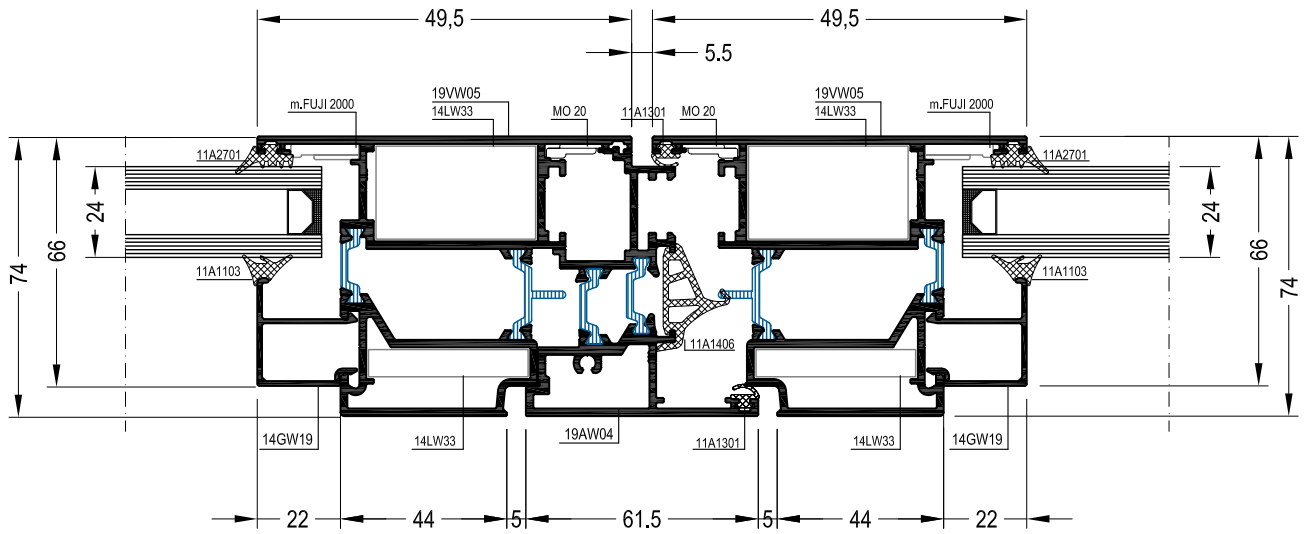
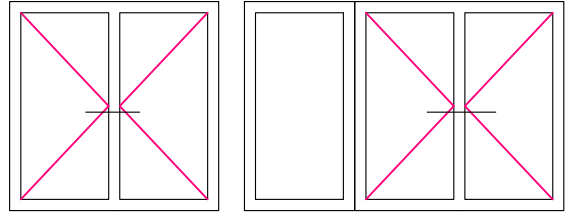

OUTSIDE OPENING DOOR

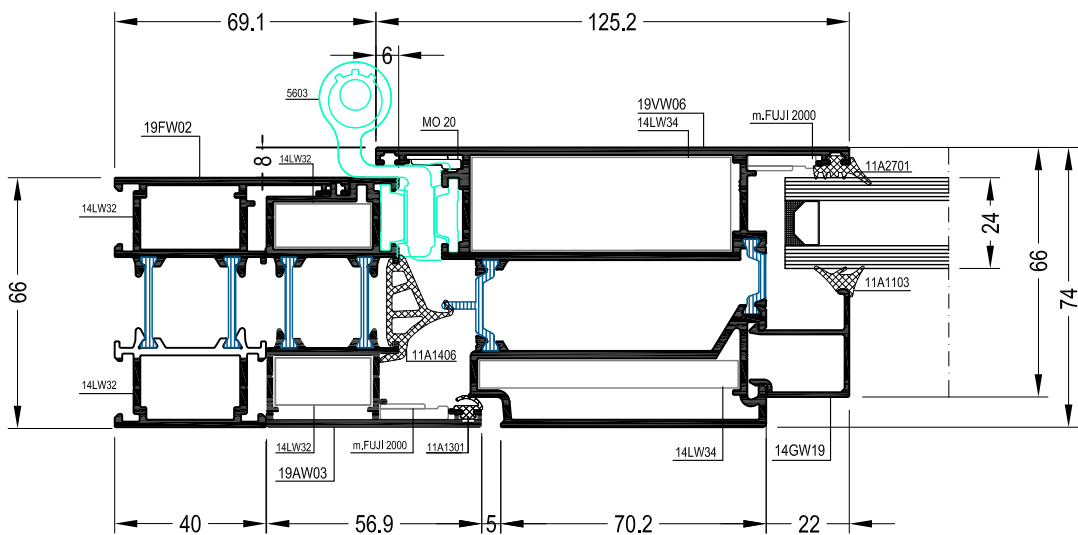
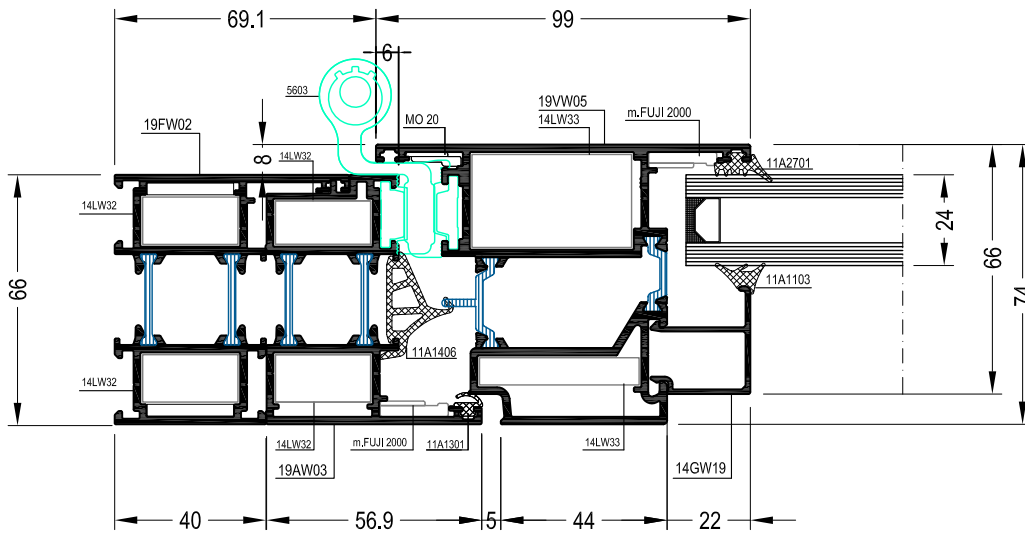
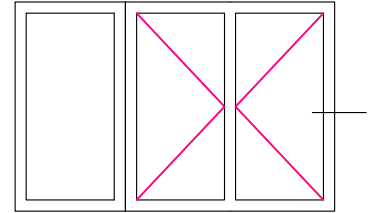

OUTSIDE OPENING DOOR

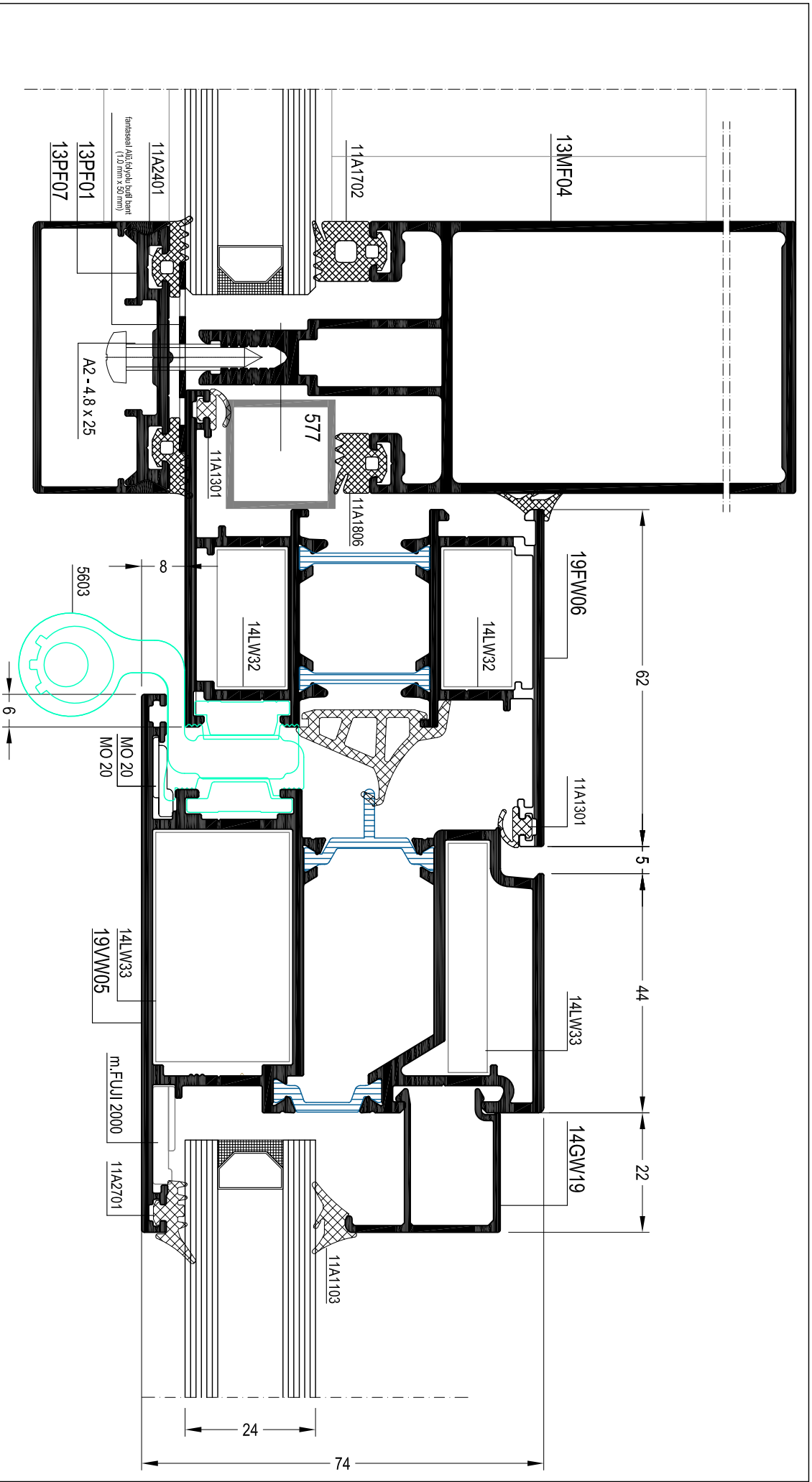

INSIDE OPENING DOOR

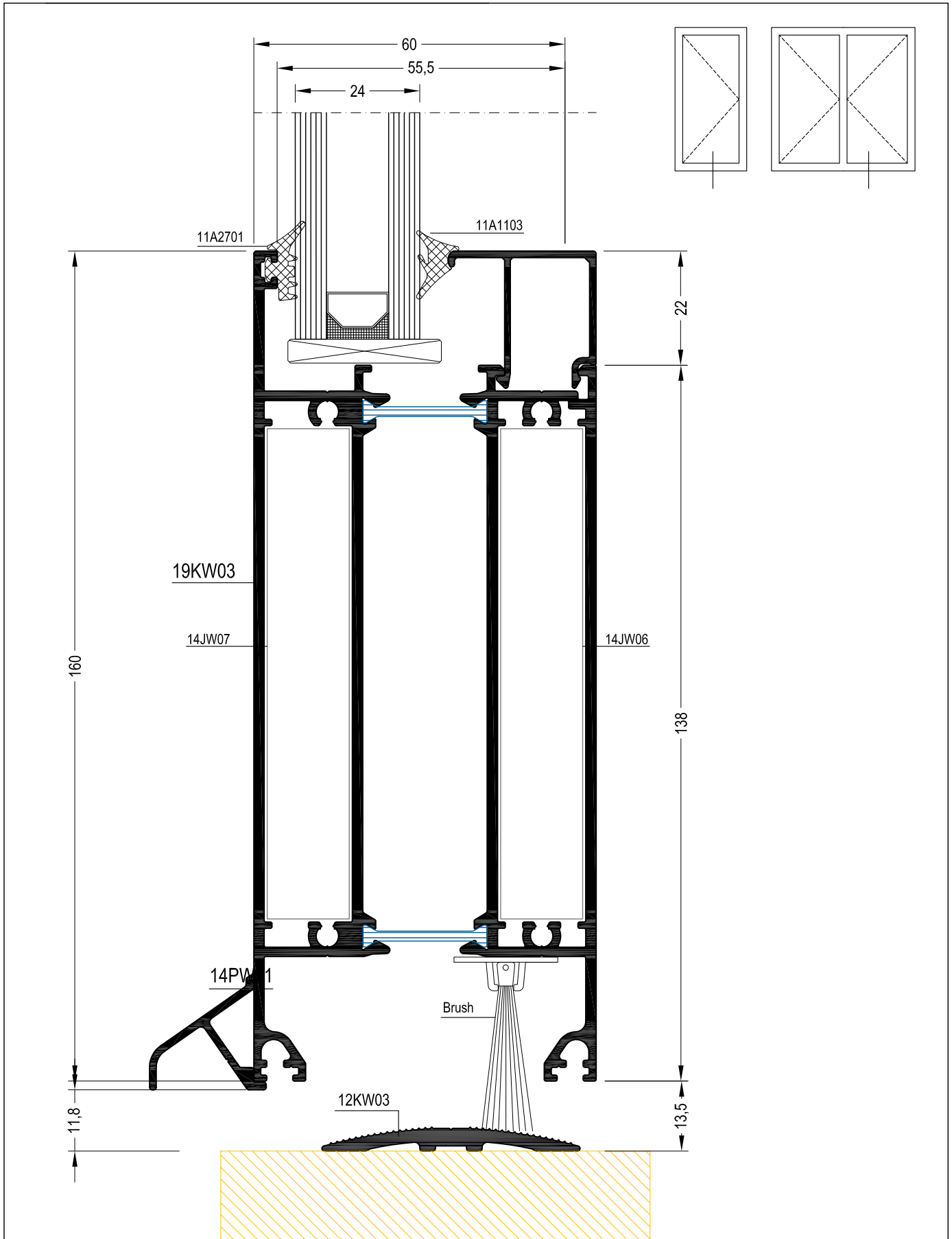

INSIDE OPENING DOOR

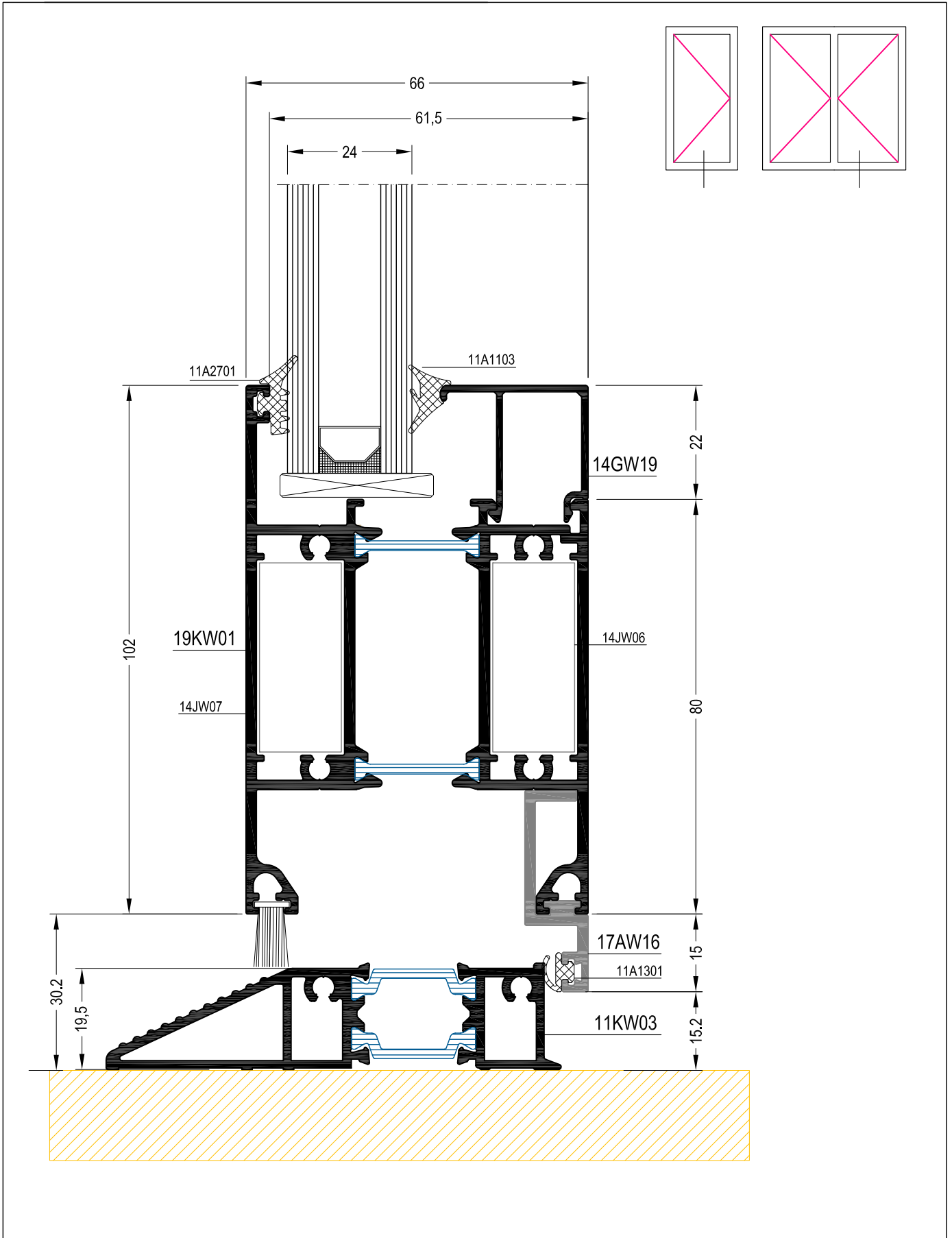

INSIDE OPENING DOOR

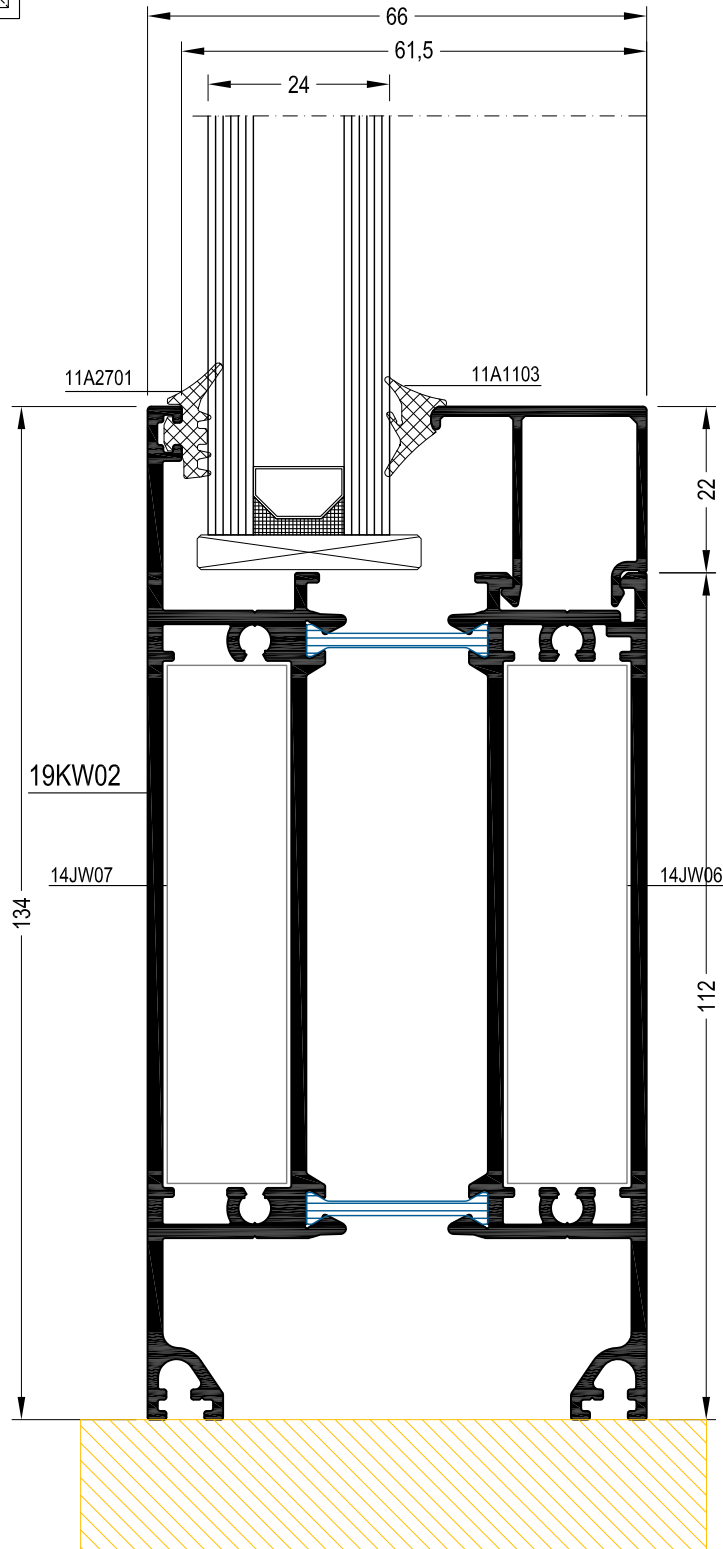
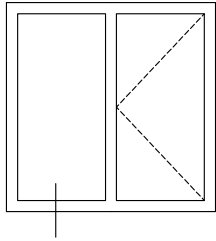

PIVOT WINDOW

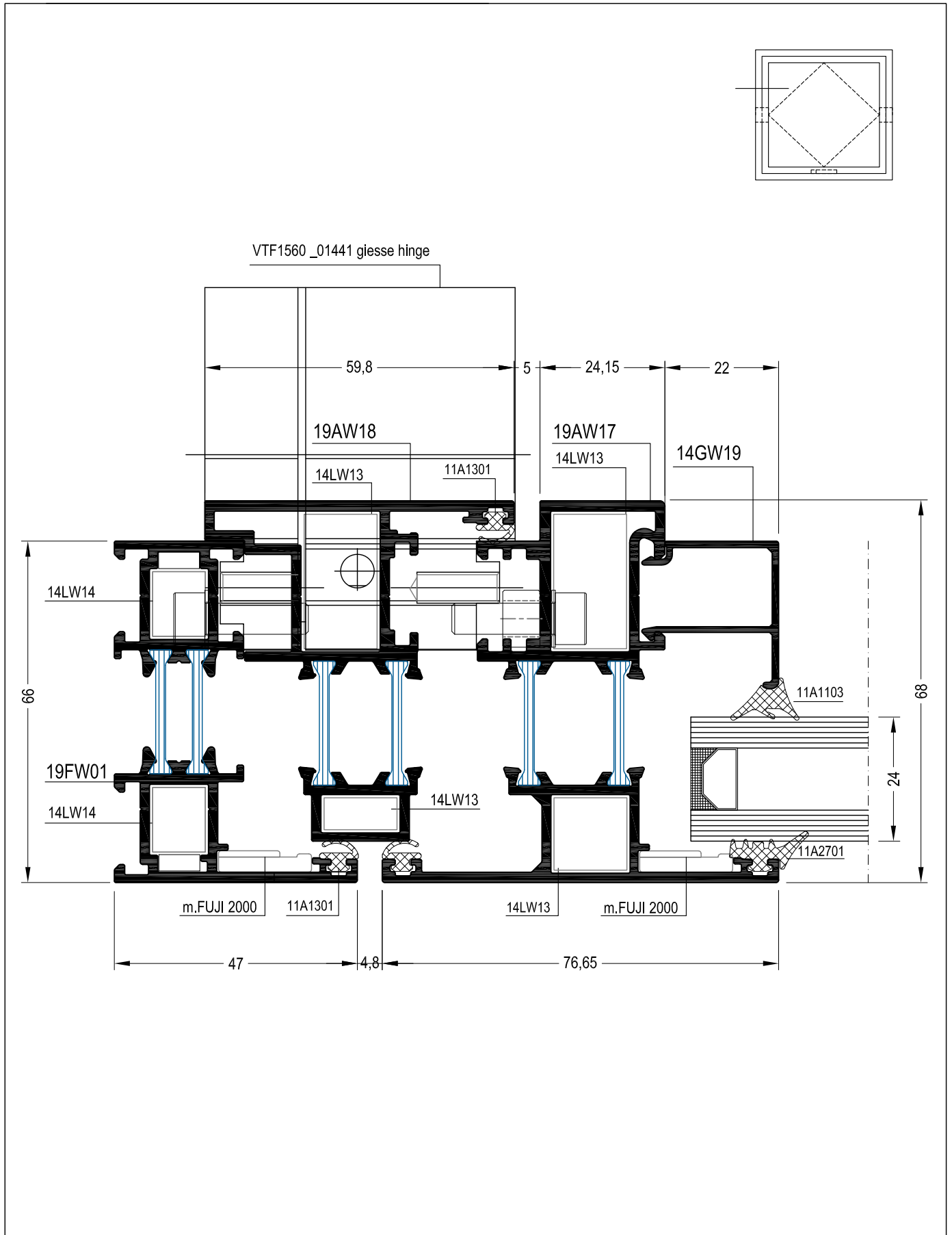

PIVOT WINDOW

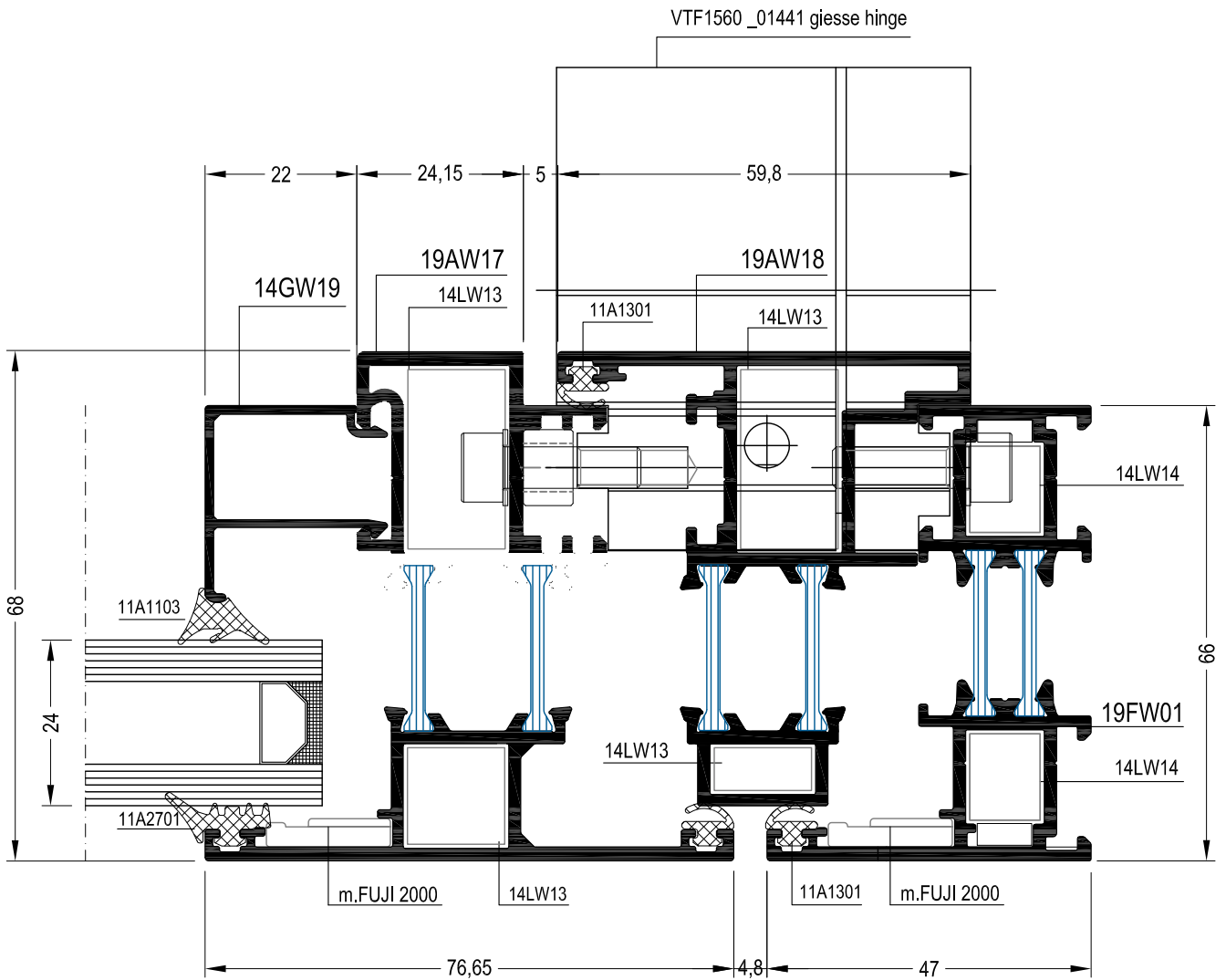
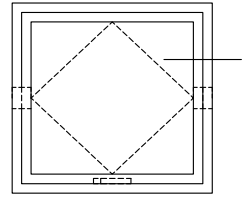

PIVOT WINDOW

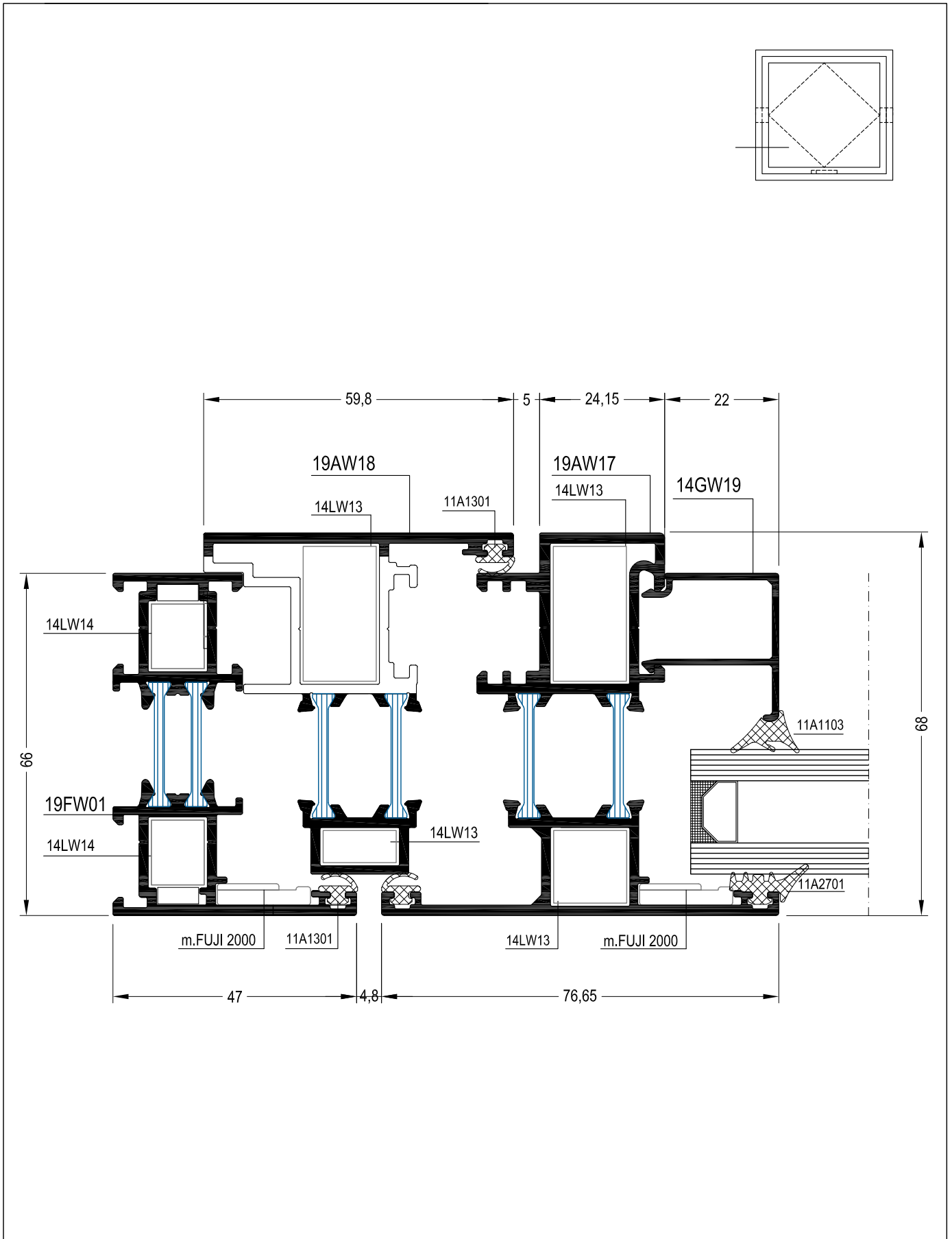

PIVOT WINDOW

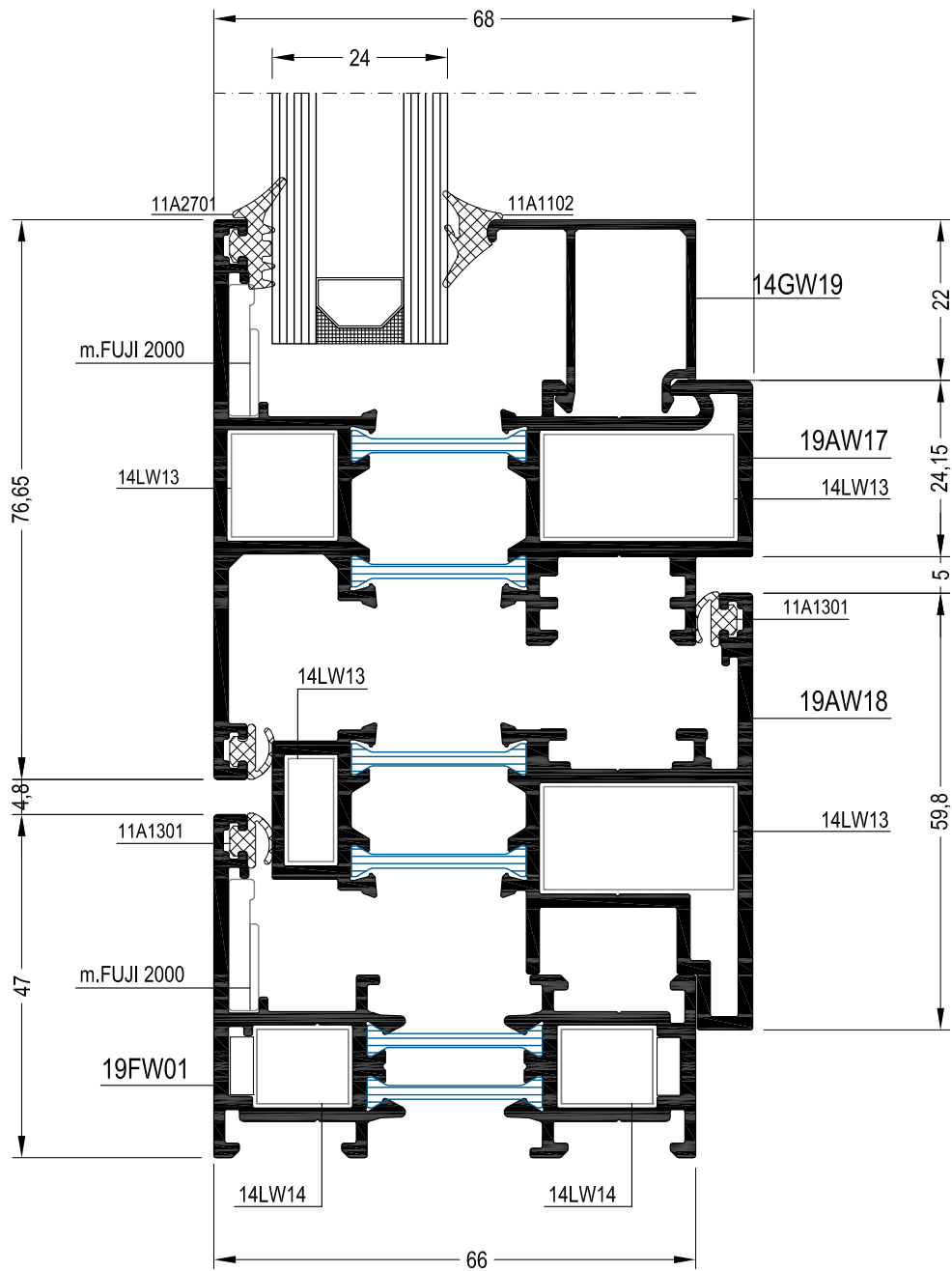
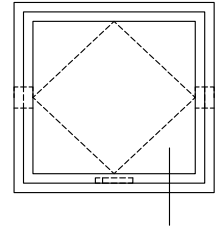

FOLDING DOOR

vw : Vent Width

TYPE 321

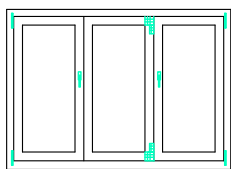

TYPE 330

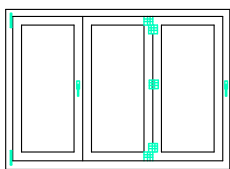

TYPE 431

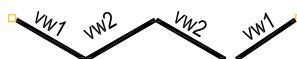
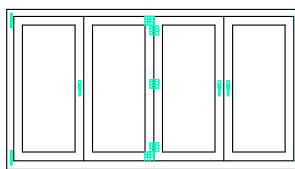

TYPE 541

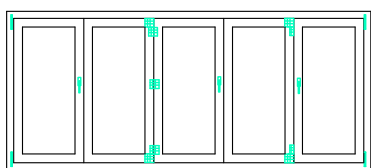

TYPE 550

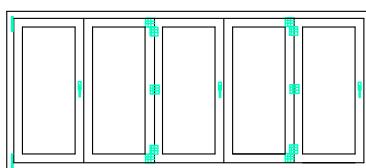

TYPE 532

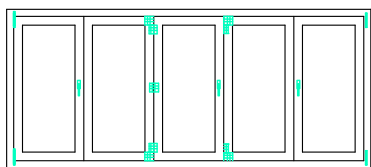

TYPE 651

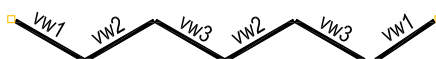
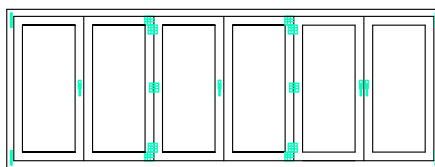

TYPE 633

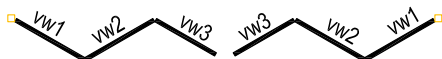
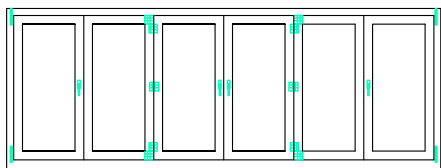

TYPE 761

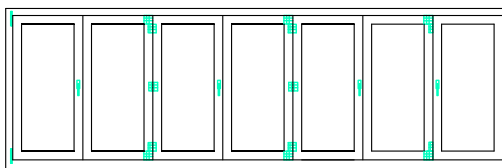

TYPE 770

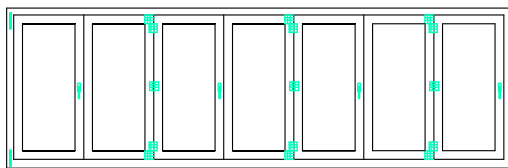

TYPE 743

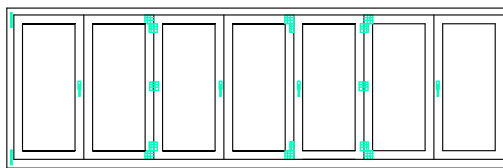

FOLDING DOOR

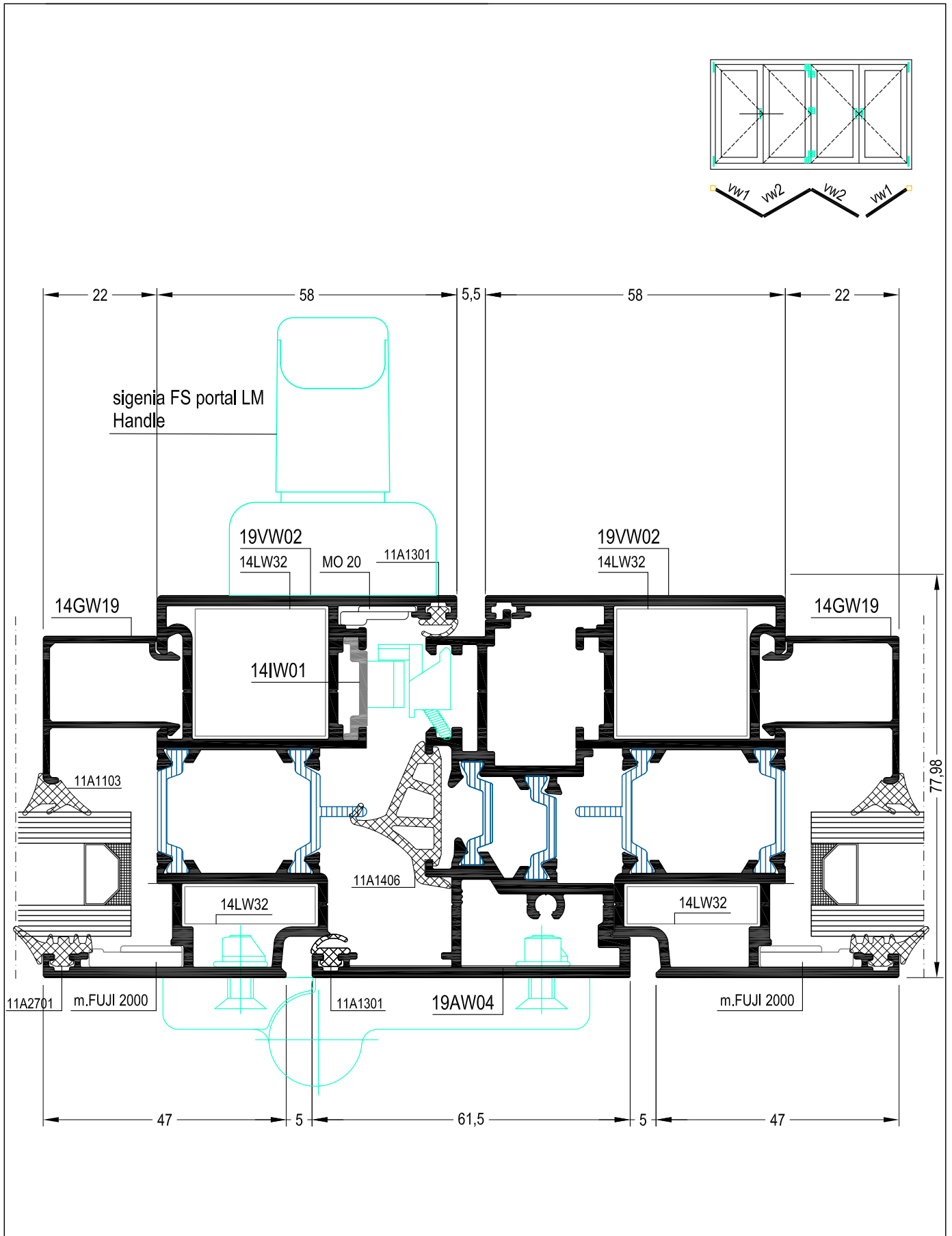

FOLDING DOOR

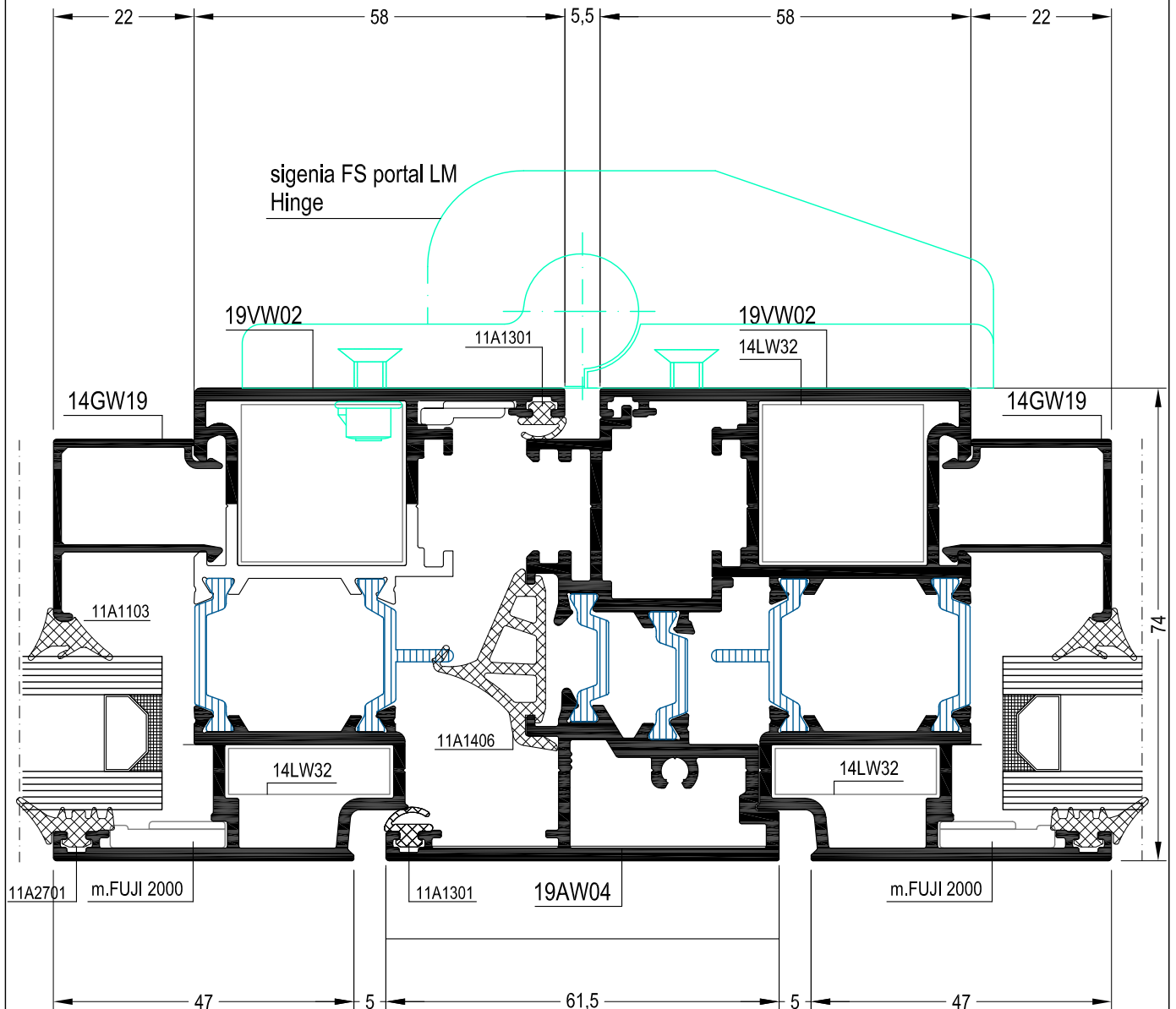
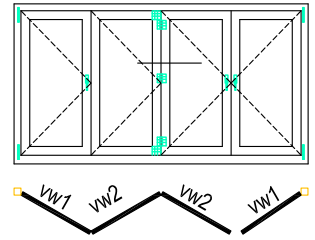

FOLDING DOOR

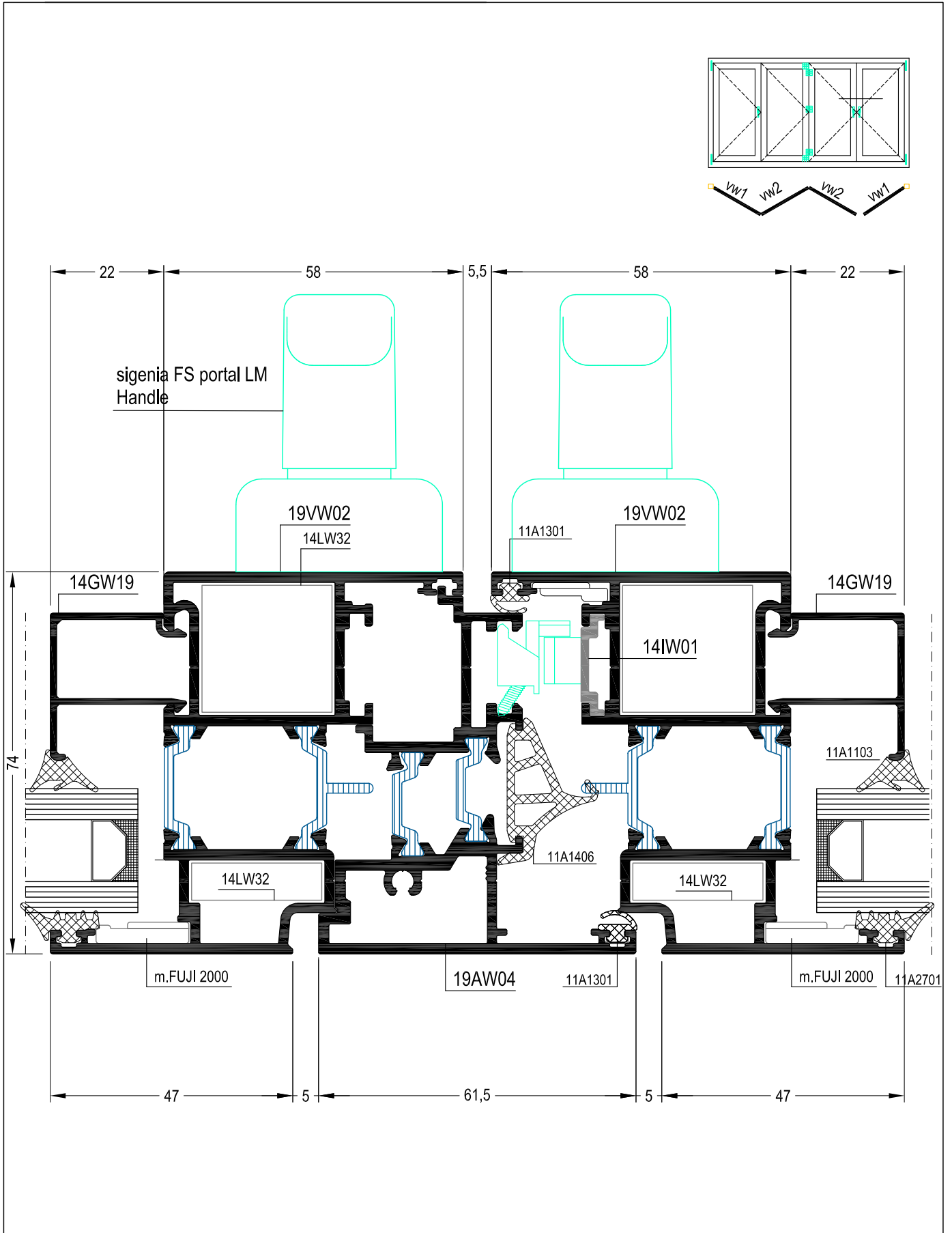

FOLDING DOOR

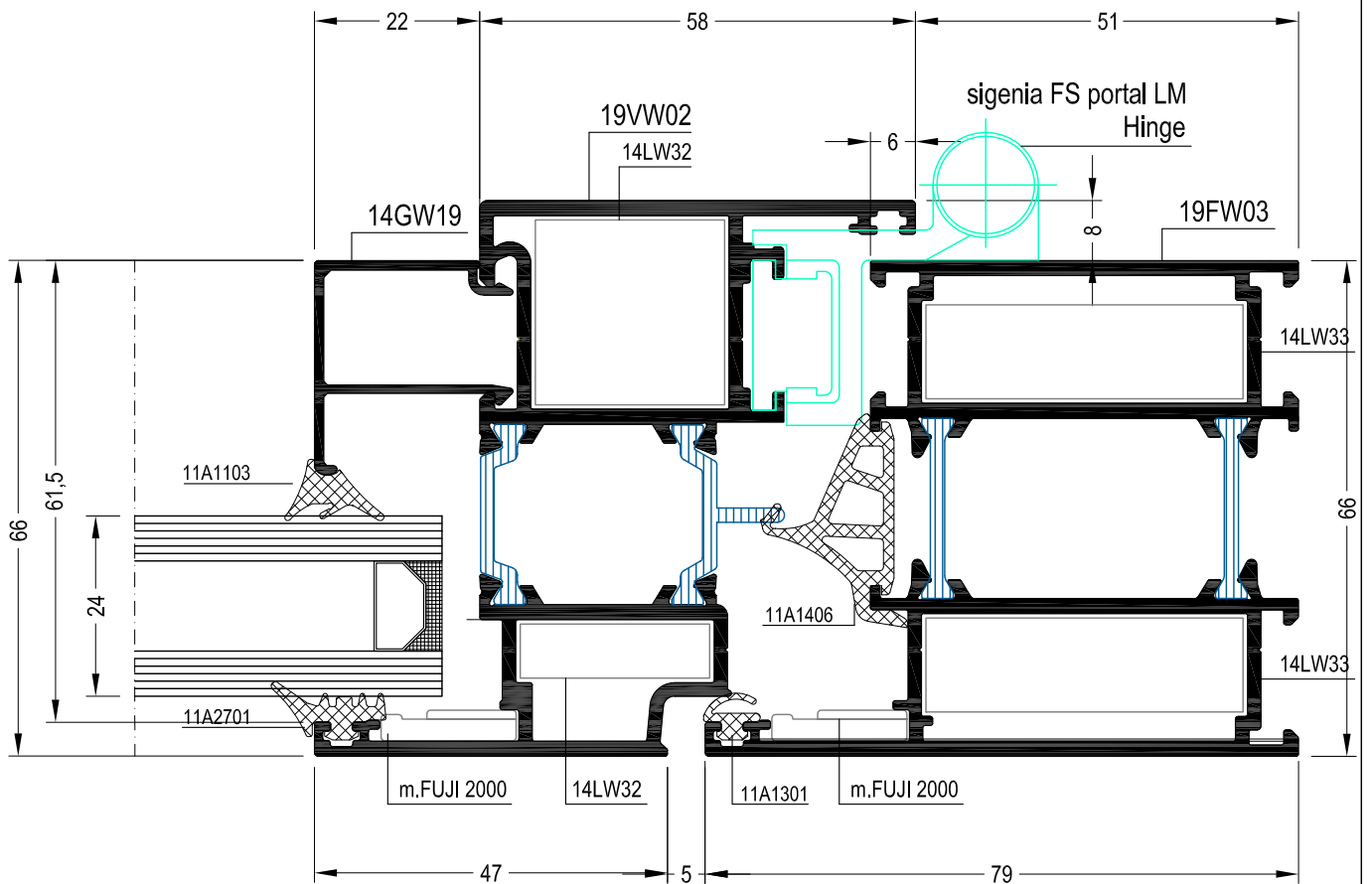
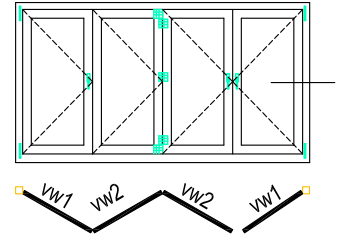

FOLDING DOOR

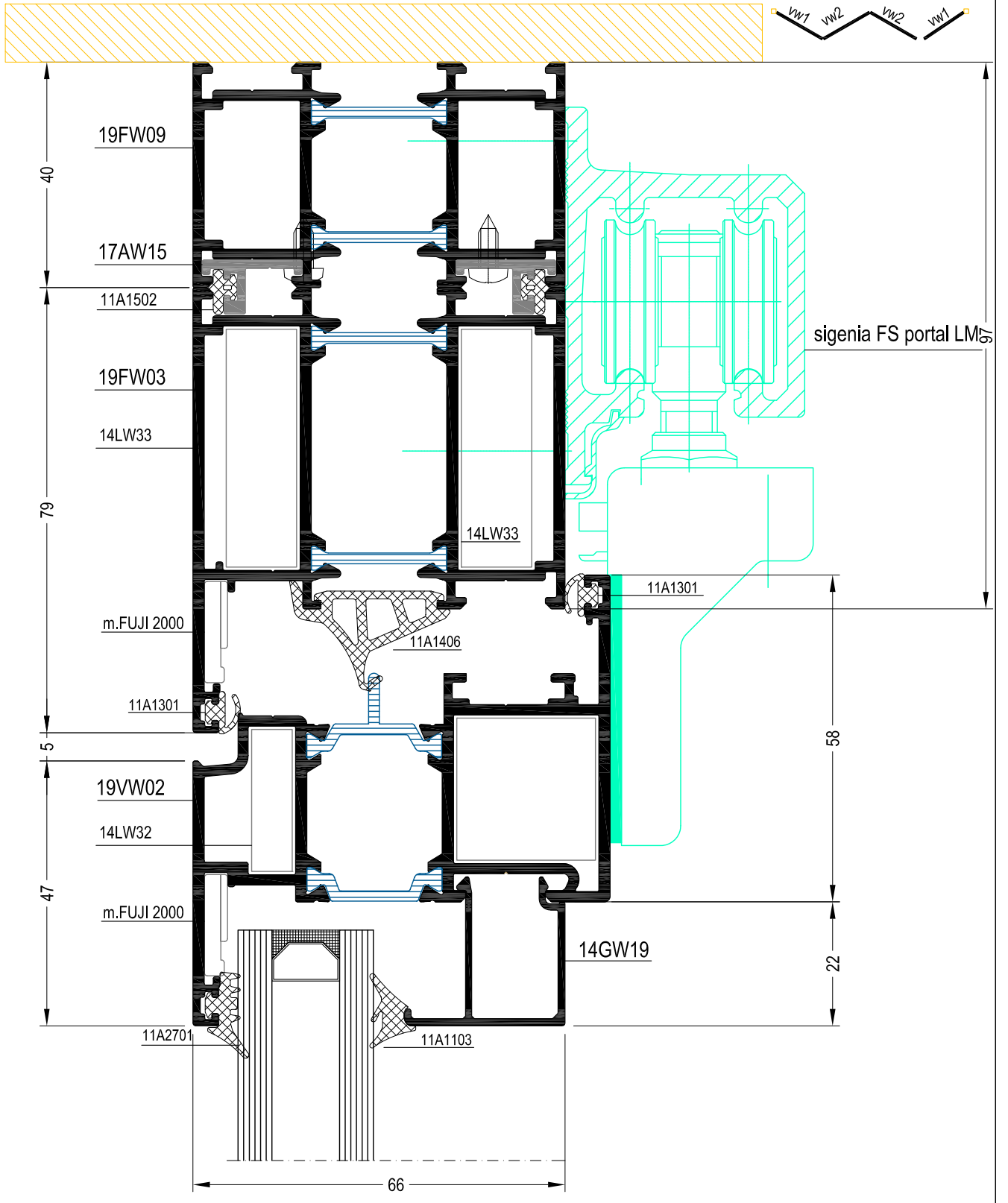
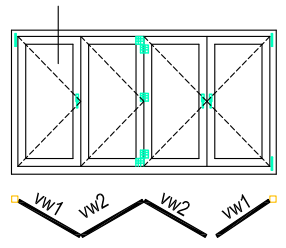

FOLDING DOOR

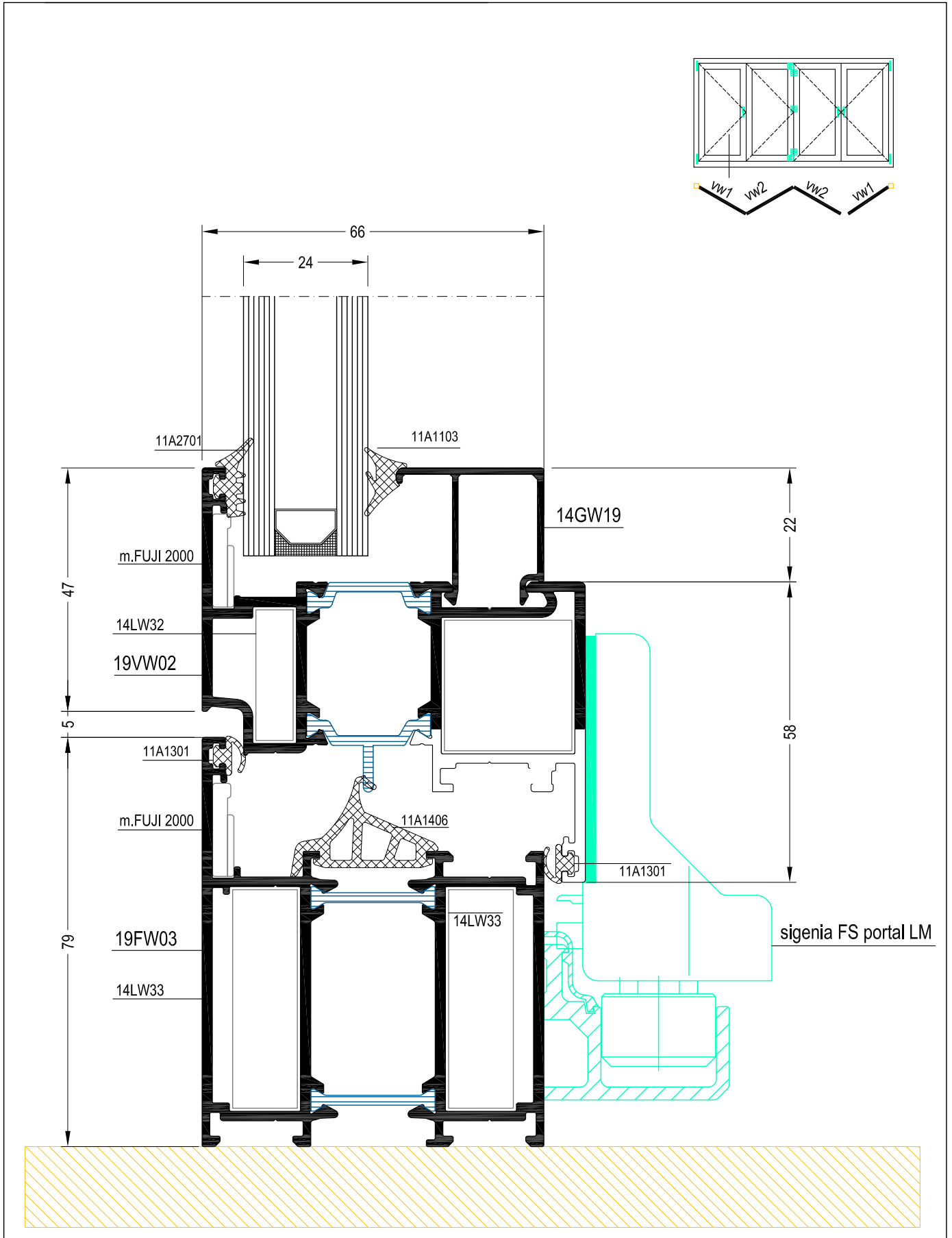

FOLDING DOOR

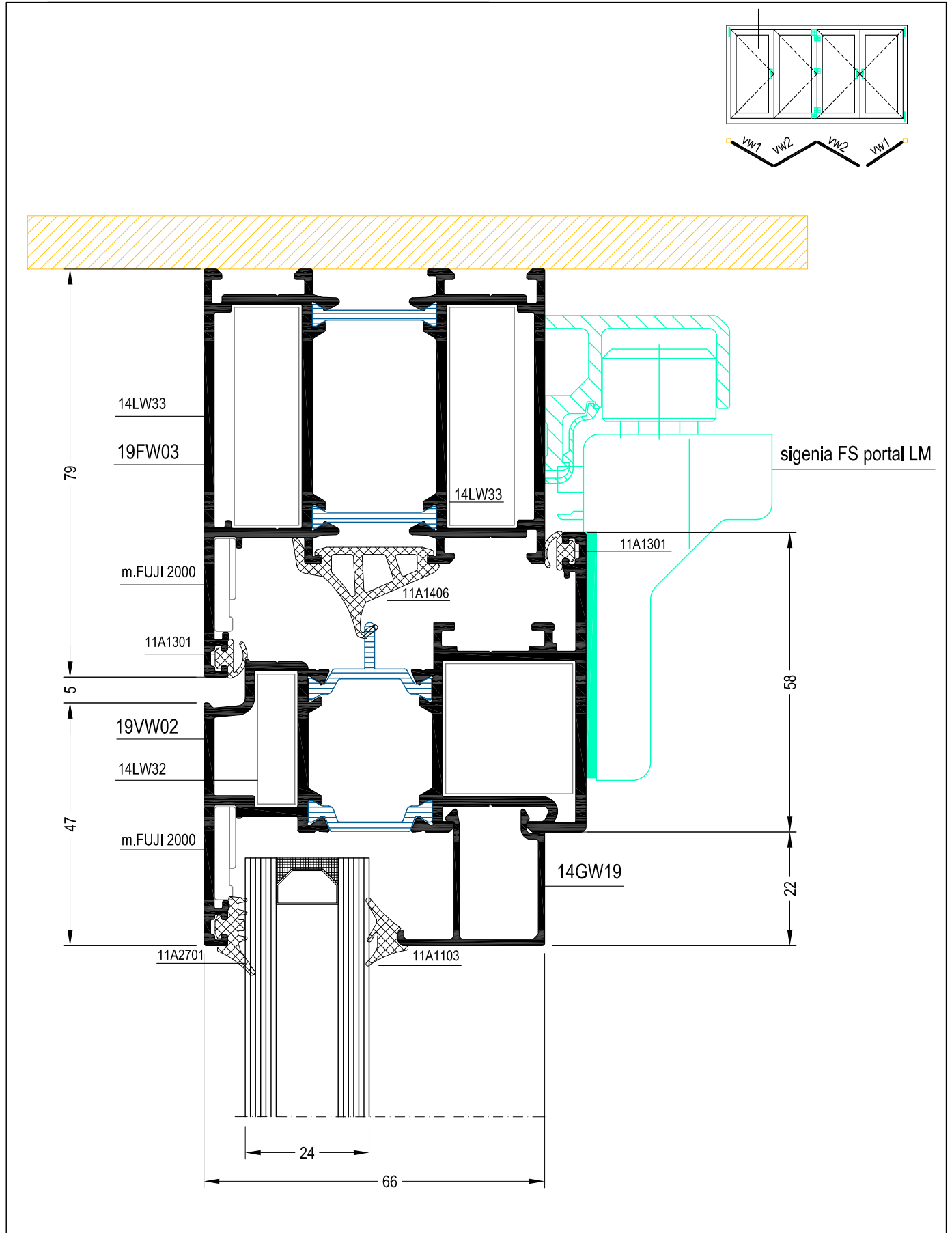

FOLDING DOOR

